

---

**TECHNE**

**IFB-121**  
**Industrial Fluidised Bath System**

**OPERATOR'S MANUAL**



**Barloworld**  
Scientific

Issue 9  
01/07

---

### INDUSTRIAL FLUIDISED BATH SYSTEM

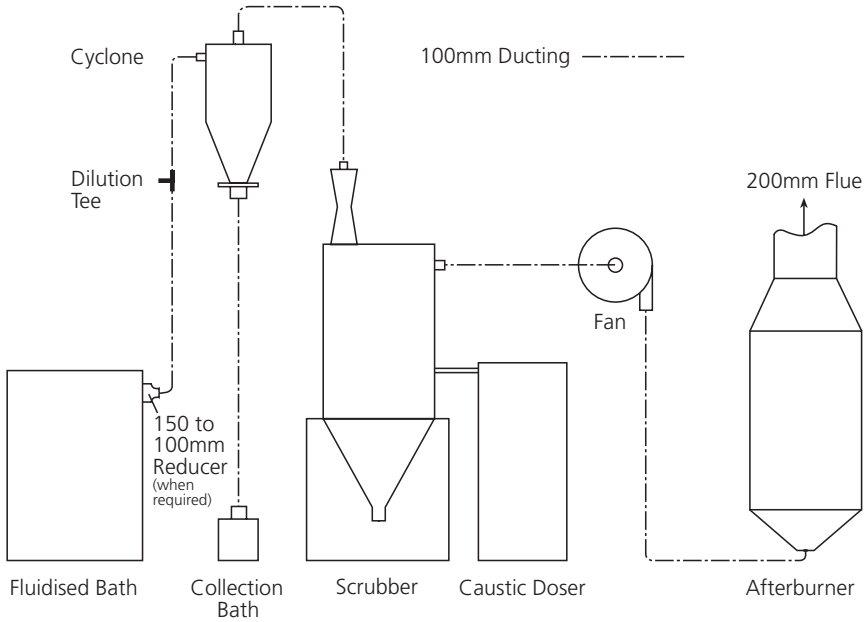


Fig 1

**IFB-121 OPERATOR'S MANUAL**

<b>CONTENTS</b>	<b>PAGE</b>
<b>SAFETY and INSTALLATION</b>	
English	2
Français	5
Deutsch	8
Español	11
Italiano	14
<b>OPERATOR SAFETY</b>	17
Warning note	17
General description	18
Technical Specification	20
<b>INSTALLATION</b>	21
Fume ignition	23
Fume cleaning	24
<b>OPERATION</b>	25
Operating procedures for plastic residue	26
<b>MAINTENANCE</b>	28
Maintenance procedures for PVC etc	28
<b>FAULT FINDING</b>	30
Spare parts	32
Accessories	33
Diagrams	34

## SAFETY AND INSTALLATION

Please read all the information in this booklet before using the unit.

### WARNING

HIGH TEMPERATURES ARE DANGEROUS: they can cause serious burns to operators and ignite combustible material.

Techne have taken great care in the design of these units to protect operators from hazards, but Operators should pay attention to the following points:

- USE CARE AND WEAR PROTECTIVE GLOVES TO PROTECT HANDS.
- DO NOT put hot objects on or near combustible objects.
- DO NOT operate the unit close to inflammable liquids or gases.
- DO NOT place any liquid directly in your unit.
- At all times USE COMMON SENSE.

### OPERATOR SAFETY

All users of Techne equipment must have available the relevant literature needed to ensure their safety. It is important that only suitably trained personnel operate this equipment, in accordance with the instructions contained in this manual and with general safety standards and procedures. If the equipment is used in a manner not specified by Techne the protection provided by the equipment to the Operator may be impaired.

All Techne units have been designed to conform to international safety requirements and are fitted with an overtemperature cutout. On some models, the cutout is adjustable and should be set to suit the application. On all other models the cutout is preset to protect the unit.

If a safety problem should be encountered, switch off at the mains socket and remove the plug from the supply.

### INSTALLATION

This Techne Industrial Fluidised Bath (IFB) is designed to be operated as a permanently connected piece of equipment and must be installed by a fully qualified electrician with experience of installing 3 phase equipment.

The IFB must be installed with an appropriately rated switch and/or circuit breaker included in the building installation.

The switch or circuit breaker should be in close proximity to the IFB and within easy reach of the operator.

The switch or circuit breaker should also be clearly marked as the disconnecting device for the IFB.

The supply wiring should be of a specification suitable for the ratings indicated on the IFB rating plate; in addition it should also comply with local, national and international standards where applicable.

As every installation is unique, it is not possible to give detailed instruction regarding any drilling of the cabinet base plate that may be required for routing of the supply cable. However, the cable must be adequately secured with a suitably approved cable gland at the point it enters the cabinet. It is also a requirement that the earth conductor is terminated in such a way that it is longer than the 3 phase conductors and also longer than the neutral conductor. This is to prevent, in the case of the supply cable becoming insecure, the earth conductor disconnecting before the other 4 conductors.

#### **AFTER USE**

When you have finished heating samples, remember that parts of the unit – the tubes, blocks and associated accessories – may be very hot. Take the precautions listed earlier.

#### **GUARANTEE**

The unit is guaranteed against any defect in material or workmanship for the period specified on the enclosed guarantee card. This period is from the date of purchase, and within this period all defective parts will be replaced free of charge provided that the defect is not the result of misuse, accident or negligence. Servicing under this guarantee should be obtained from the supplier.

Notwithstanding the description and specification(s) of the units contained in the Operator's Manual, Techne hereby reserves the right to make such changes as it sees fit to the units or to any component of the units.

This Manual has been prepared solely for the convenience of Techne customers and nothing in this Instruction Book shall be taken as a warranty, condition or representation concerning the description, merchantability, fitness for purpose or otherwise of the units or components.

## OPERATOR MAINTENANCE

NOTE: THAT THIS EQUIPMENT SHOULD ONLY BE DISMANTLED BY PROPERLY TRAINED PERSONNEL. REMOVING THE SIDE, FRONT OR REAR PANELS EXPOSES POTENTIALLY LETHAL MAINS VOLTAGES. THERE ARE NO OPERATOR MAINTAINABLE PARTS WITHIN THE EQUIPMENT.

In the unlikely event that you experience any problems with your unit which cannot easily be remedied, you should contact your supplier and return the unit if necessary. Please include any details of the fault observed and remember to return the unit in its original packing. Techne accept no responsibility for damage to units which are not properly packed for shipping: if in doubt, contact your supplier. See the Decontamination Certificate supplied with your unit.

### 1. Cleaning

Before cleaning your unit ALWAYS disconnect it from the power supply and allow it to cool below 50°C.

Your unit can be cleaned by wiping with a damp soapy cloth. Care should be exercised to prevent water from running inside the unit. Do not use abrasive cleaners.

### 2. Overtemperature cutout

In the event of no heater power, check the mains plug and lead. Repeated operation of the cutout indicates a serious fault: you may need to return the unit to your supplier for repair.

### 3. Fuses

Your unit is protected by one or two fuses. These should only be changed by suitably qualified personnel. If the fuses blow persistently, a serious fault is indicated and you may need to return the unit to your supplier for repair.

## INTRODUCTION

Veuillez lire attentivement toutes les instructions de ce document avant d'utiliser l'appareil.

## AVERTISSEMENT

**DANGER DE TEMPERATURES ELEVEES** : les opérateurs peuvent subir de graves brûlures et les matériaux combustibles risquent de prendre feu.

Techne a apporté un soin tout particulier à la conception de ces appareils de façon à assurer une protection maximale des opérateurs, mais il est recommandé aux utilisateurs de porter une attention spéciale aux points suivants :

- PROCEDER AVEC SOIN ET PORTER DES GANTS POUR SE PROTEGER LES MAINS.
- NE PAS poser d'objets chauds sur ou près de matériaux combustibles.
- NE PAS utiliser l'appareil à proximité de liquides ou de gaz inflammables.
- NE PAS verser de liquide directement dans l'appareil.
- FAIRE TOUJOURS PREUVE DE BON SENS.

## SÉCURITÉ DE L'OPÉRATEUR

Tous les utilisateurs de produits Techne doivent avoir pris connaissance des manuels et instructions nécessaires à la garantie de leur sécurité.

Important : cet appareil doit impérativement être manipulé par un personnel qualifié et utilisé selon les instructions données dans ce document, en accord avec les normes et procédures de sécurité générales. Dans le cas où cet appareil ne serait pas utilisé selon les consignes précisées par Techne, la protection pour l'utilisateur ne serait alors plus garantie.

Tous les appareils Techne sont conçus pour répondre aux normes de sécurité internationales et sont dotés d'un coupe-circuit en cas d'excès de température. Sur certains modèles, ce coupe-circuit est réglable pour s'adapter à l'application désirée. Sur d'autres modèles, il est pré-réglé en usine pour assurer la protection de l'appareil.

Dans le cas d'un problème de sécurité, coupez l'alimentation électrique au niveau de la prise murale et enlevez la prise connectée à l'appareil.

## INSTALLATION

1. Tous les appareils Techne sont livrés avec un câble d'alimentation qui peut être intégré à l'appareil ou à raccorder.
2. Avant de brancher l'appareil, vérifiez la tension requise indiquée sur la plaque d'identification. Raccordez le câble électrique à la prise appropriée en vous reportant au tableau ci-dessous. Il est important que l'appareil soit relié à la terre pour assurer la protection électrique requise.

<i>Connexions</i>	<i>220V-240 V</i>	<i>110V-120 V</i>
Phase	marron	noir
Neutre	bleu	blanc
Terre	vert/jaune	vert

Le fusible à l'intérieur de l'appareil est destiné à assurer la protection de l'appareil et de l'opérateur.

Remarque : les appareils dont la plaque indique 230 V peuvent fonctionner sur 220 V, et ceux dont la plaque indique 120 V peuvent fonctionner sur 110 V. Dans les deux cas cependant, la capacité de chauffage diminuera d'environ 8 %. La plaque d'identification se trouve à l'arrière de l'appareil.

3. Raccordez le câble d'alimentation à la prise située à l'arrière de l'appareil.
4. Placez l'appareil sur un plan de travail ou surface plane, ou le cas échéant, dans une hotte d'aspiration, en s'assurant que les trous d'aération situés sous l'appareil ne soient pas obstrués.
5. Les symboles situés sur ou à côté de l'interrupteur de l'appareil ont la signification suivante :

- I arrêt
- O marche

## APRÈS UTILISATION

Lorsque vous avez fini de chauffer les échantillons, n'oubliez pas que certaines parties de l'appareil - les éprouvettes, leurs supports et autres accessoires - risquent d'être très chaudes. Il est donc recommandé de toujours prendre les précautions citées plus haut.

## GARANTIE

L'appareil est garanti contre tout défaut ou visde fabrication pour la durée figurant sur la carte de garantie, à compter de la date d'achat de l'appareil. Au cours de cette période, toutes les pièces défectueuses seront remplacées gratuitement, dans la mesure où la défaillance n'est pas due à une mauvaise utilisation, un accident ou une négligence. Toute réparation sous garantie sera effectuée par le fournisseur.

Malgré la description et les spécifications de l'appareil données dans le manuel de l'utilisateur, Techne se réserve le droit d'effectuer les changements nécessaires à l'appareil ou à tout élément qui entre dans sa composition.

Ce manuel a été exclusivement rédigé à l'attention des clients de Techne, et aucun élément de ce guide d'instructions ne peut être utilisé comme garantie, condition ou représentation concernant la description, commercialisation, adaptation aux conditions d'utilisation ou autre des appareils ou leurs composants.

## ENTRETIEN UTILISATEUR

**IMPORTANT : CET APPAREIL NE PEUT ETRE DEMONTE QUE PAR DU PERSONNEL QUALIFIE.**

LORSQUE LES PANNEAUX AVANT, ARRIERE ET LATERAUX SONT DEMONTES, L'OPERATEUR EST EXPOSE A DES TENSIONS QUI PEUVENT ETRE MORTELLES.

CET APPAREIL NE CONTIENT AUCUN ELEMENT QUI DEMANDE UN ENTRETIEN DE LA PART DE L'UTILISATEUR.



Dans le cas peu probable où votre appareil présente un défaut de fonctionnement auquel il est difficile de remédier, il est alors préférable de contacter votre fournisseur et, le cas échéant, de renvoyer le matériel. Veuillez inclure une description détaillée du problème constaté et retourner l'appareil dans son emballage d'origine. Techne ne sera pas tenu responsable des dommages subis par tout appareil dont l'emballage est inadéquat pour le transport. Pour plus de sûreté, contactez votre fournisseur. Voir le certificat de décontamination livré avec le produit.

### **1. Nettoyage**

Avant de nettoyer l'appareil, assurez-vous TOUJOURS que le câble d'alimentation est déconnecté et laissez la température redescendre en dessous de 50 °C.

Utilisez un chiffon imprégné d'eau savonneuse pour nettoyer l'appareil. Veillez à ne pas introduire d'eau dans l'appareil. N'utilisez pas de produits abrasifs.

### **2. Coupe-circuit d'excès de température**

- En l'absence de puissance de chauffe, vérifiez la prise et le câble d'alimentation puis réglez la commande du coupe-circuit (si votre appareil est doté de ce mécanisme).
- Si la sécurité se déclenche trop souvent, il s'agit d'un problème plus sérieux. Nous vous conseillons dans ce cas de prendre contact avec votre fournisseur pour réparation.

### **3. Fusibles**

La protection de l'appareil est assurée par un ou deux fusibles dont le remplacement ne peut être effectué que par un personnel qualifié.

Si les fusibles sautent sans arrêt, il s'agit d'un problème sérieux. Nous vous conseillons dans ce cas de prendre contact avec votre fournisseur pour réparation.

## EINLEITUNG

Bitte lesen Sie diese Bedienungsanleitung komplett bevor Sie dieses Gerät benutzen.

## WARNUNG

HOHE TEMPERATUREN SIND GEFÄHRLICH: sie können dem Bediener ernsthafte Verletzungen zufügen und brennbare Materialien können sich leicht entzünden.

Techne hat bei der Konstruktion dieses Gerätes sehr darauf geachtet, daß der Bediener vor Gefahren geschützt ist. Dennoch sollten Sie auf die folgenden Punkte achten:

- SEIEN SIE VORSICHTIG UND TRAGEN SIE SCHUTZHANDSCHUHE.
- Legen Sie heiße Gegenstände NICHT auf oder in die Nähe von leicht brennbaren Materialien. vermeiden Sie Arbeiten in der Nähe von leicht entzündbaren Flüssigkeiten oder Gasen.
- Bringen sie KEINE Flüssigkeiten direkt in Ihr Gerät.
- Benutzen Sie immer den normalen Menschenverstand.

## SICHERHEIT DES ANWENDERS

Alle Benutzer von Techne Geräten müssen Zugang zu der entsprechenden Literatur haben, um ihre Sicherheit zu gewähren.

Es ist wichtig, daß diese Geräte nur von entsprechend geschultem Personal betrieben werden, das die in dieser Gebrauchsanweisung enthaltenen Maßnahmen und allgemeine Sicherheitsbestimmungen und -vorkehrungen beachtet. Wenn das Gerät anders eingesetzt wird als vom Hersteller empfohlen, kann dies die persönliche Sicherheit des Anwenders beeinträchtigen. Die Geräte von Techne entsprechen den internationalen Sicherheitsbestimmungen und sind mit einem automatischen Übertemperaturabschalter ausgestattet. Bei einigen Modellen ist der Übertemperaturabschalter verstellbar und sollte je nach Anwendung entsprechend eingestellt werden. Bei allen anderen Modellen ist der Temperaturschutz voreingestellt um Schäden am Gerät zu vermeiden. Wenn ein Sicherheitsproblem auftreten sollte, muß das Gerät ausgeschaltet und vom Stromnetz getrennt werden.

## INSTALLATION

1. Alle Techne Geräte werden mit einem Stromanschlußkabel geliefert. Dieses ist entweder fest mit dem Gerät verbunden oder zum Einstecken.
2. Vergleichen Sie, ob die Spannung Ihrer Stromversorgung mit den Angaben auf dem Typenschild des Geräte übereinstimmen. Verbinden Sie das Stromanschlußkabel mit einer geeigneten Stromversorgung gemäß der nächstehenden Tabelle.

**Achtung: Das Gerät muß geerdet sein, um die elektrische Sicherheit zu gewährleisten!**

<i>Verbindungen</i>	<i>220V-240V</i>	<i>110V-120V</i>
Stromführend	Braun	Schwarz
Neutral	Blau	Weiß
Erde	Grün/Gelb	Grün

Geräte, die für 230 Volt ausgelegt sind, können auch bei 220 Volt arbeiten, Geräte für 120 Volt auch bei 110 Volt. In beiden Fällen verringert sich die Aufheizrate um ca. 8%. Das Typenschild befindet sich hinten am Gerät.

3. Stecken Sie das Stromkabel in die vorgesehene Buchse hinten am Gerät.
4. Stellen Sie das Gerät auf eine ebene Arbeitsfläche bzw. (falls erforderlich) unter einen Laborabzug. Beachten Sie, daß die Entlüftungsrippen an der Geräteunterseite immer frei zugänglich sind.
5. Die Symbole auf oder neben dem EIN/AUS-Schalter an der Geräterückseite bedeuten:
  - I An
  - O Aus

## **NACH DEM GEBRAUCH**

Vergessen Sie nicht, daß Teile des Gerätes (die Gefäße, die Blöcke und andere Zubehöerteile) nach dem Erhitzen von Proben noch sehr heiß sein können. Bitte beachten Sie die oben genannten Vorsichtsmaßnahmen.

## **GARANTIE**

Die Garantiedauer des Gerätes ist auf der beiliegenden Garantiekarte angegeben und schließt Fehler im Material oder der Verarbeitung ein. Die Garantiedauer beginnt am Tag des Einkaufs. Sämtliche defekte Teile werden innerhalb dieses Zeitraumes kostenlos ersetzt unter der Voraussetzung, daß dem Defekt keine unsachgemäße Handhabung, Fahrlässigkeit oder ein Unfall zugrundeliegt. Der unter diese Garantie fallende Service wird vom Lieferanten geleistet.

Ungeachtet der in dieser Gebrauchsanweisung enthaltenen Beschreibungen und Spezifikationen, behält sich Techne hiermit das Recht vor, Änderungen an den Geräten bzw. an einzelnen Geräteteilen durchzuführen.

Diese Gebrauchsanleitung wurde ausschließlich dazu erstellt, um Kunden die Handhabung der Techne-Geräte zu erleichtern. Nichts in dieser Gebrauchsanleitung darf als Garantie, Bedingung oder Voraussetzung verstanden werden, sei es die Beschreibung, Marktgängigkeit, Zweckdienlichkeit oder sonstiges bezüglich der Geräte oder deren Bestandteile.

## **WARTUNG DURCH DEN BEDIENER**

BEACHTEN SIE, DASS DIESES GERÄT NUR VON TECHNISCHEN FACHKRÄFTEN GEÖFFNET UND DEMONTIERT WERDEN DARF.

DURCH ENTFERNEN DES GERÄUSES ODER GEHÄUSETEILEN SIND BAUTEILE MIT LEBENGEFÄHRLICHEN SPANNUNGEN FREI ZUGÄNLICH.

IM INNERN DES GERÄTES BEFINDEN SICH KEINE TEILE, DIE VOM ANWENDER GEWARTET WERDEN MÜSSEN.

Falls Ihr Gerät nicht ordnungsgemäß arbeitet, wenden Sie sich an Ihren Lieferanten oder senden Sie das Gerät wenn nötig zurück. Fügen Sie eine genaue Beschreibung des Defektes bei. Verpacken Sie das Gerät möglichst im Originalkarton. Bitte beachten Sie, daß Techne und thermo-DUX keine Haftung bei Transportschäden aufgrund unzureichender Verpackung übernehmen. Setzen Sie sich im Zweifelsfall mit Ihrem Lieferanten in Verbindung. Bitte beachten Sie die Entgiftungsbescheinigung, die Sie mit dem Gerät erhalten haben.

## 1. Reinigen

Bevor Sie Ihr Gerät reinigen, sollten Sie

- zuerst den Netzstecker ziehen.
- das Gerät unter 50°C abkühlen lassen.

Ein feuchtes Tuch mit Seifenlösung reinigt Ihr Gerät am besten. Achten Sie darauf, daß kein Wasser in das Gerät gelangt. Verwenden Sie keine Scheuermittel.

## 2. Übertemperaturabschalter

- Der Übertemperaturschutz ist ein empfindliches mechanisches Teil. Schon eine Erschütterung kann diesen auslösen.
- Falls die Heizung nicht funktioniert, überprüfen Sie zuerst Netzstecker und Kabel. Setzen Sie dann den Übertemperaturabschalter (an der Rückseite des Gerätes) wieder zurück, indem Sie den roten Knopf einmal bis zum Anschlag drücken.
- Wenn der Übertemperaturabschalter wiederholt auslöst, liegt ein größerer Defekt vor. Das Gerät muß zur Reparatur an Ihren Lieferanten eingeschickt werden.

## 3. Sicherungen

Die Stromzuleitung ist durch ein oder zwei Sicherungen geschützt. Diese sollten nur durch qualifiziertes Fachpersonal ausgetauscht werden. Wenn die Sicherung wiederholt durchbrennt, liegt ein größerer Defekt vor. Das Gerät muß zur Reparatur an Ihren Lieferanten eingeschickt werden.

## INTRODUCCIÓN

Le rogamos lea cuidadosamente la información contenida en este folleto antes de manipular el aparato.

### AVISO

LAS TEMPERATURAS ELEVADAS SON PELIGROSAS: pueden causarle graves quemaduras y provocar fuego en materiales combustibles.

Techne ha puesto gran cuidado en el diseño de estos aparatos para proteger al usuario de cualquier peligro; aún así se deberá prestar atención a los siguientes puntos:

- EXTREME LAS PRECAUCIONES Y UTILICE GUANTES PARA PROTEGERSE LAS MANOS.
- NO coloque objetos calientes encima o cerca de objetos combustibles.
- NO maneje el aparato cerca de líquidos inflamables o gases.
- NO introduzca ningún líquido directamente en el aparato.
- UTILICE EL SENTIDO COMUN en todo momento.

### SEGURIDAD DEL USUARIO

Todos los usuarios de equipos Techne deben disponer de la información necesaria para asegurar su seguridad.

De acuerdo con las instrucciones contenidas en este manual y con las normas y procedimientos generales de seguridad, es muy importante que sólo personal debidamente capacitado opere estos aparatos. De no ser así, la protección que el equipo le proporciona al usuario puede verse reducida.

Todos los equipos Techne han sido diseñados para cumplir con los requisitos internacionales de seguridad y traen incorporados un sistema de desconexión en caso de sobret temperatura. En algunos modelos el sistema de desconexión es variable, lo que le permite elegir la temperatura según sus necesidades. En otros, el sistema de desconexión viene ya ajustado para evitar daños en el equipo.

En caso de que surgiera un problema de seguridad, desconecte el equipo de la red.

### INSTALACIÓN

1. Todos los aparatos Techne se suministran con un cable de alimentación. Puede ser fijo o independiente del aparato.
2. Antes de conectarlo, compruebe que el voltaje corresponde al de la placa indicadora. Conecte el cable de alimentación a un enchufe adecuado según la tabla expuesta a continuación. El equipo debe estar conectado a tierra para garantizar la seguridad eléctrica.

<i>Conexiones</i>	<i>220V-240V</i>	<i>110V-120V</i>
Línea	Marrón	Negro
Neutro	Azul	Blanco
Tierra	Verde/amarillo	Verde

Asegúrese de que los equipos marcados 230V en la placa indicadora funcionan a 220V y de que los equipos marcados 120V funcionan a 110V. No obstante, en ambos casos la velocidad de calentamiento se verá reducida en un 8% aproximadamente. La placa indicadora está situada en la parte posterior del equipo.

3. Conecte el cable a la toma de tensión en la parte posterior del equipo.
4. Sitúe el aparato en un lugar apropiado tal como una superficie de trabajo plana, o si fuera necesario incluso en una campana con extractor de humos, asegurándose de que las entradas de aire en la parte inferior no queden obstruidas.
5. Los símbolos, que se encuentran en o cerca del interruptor de alimentación tienen los siguientes significados:
  - I Interruptor principal encendido
  - O Interruptor principal apagado

## DESPUÉS DE SU USO

Cuando haya finalizado el calentamiento de muestras, recuerde que las piezas del equipo, tales como tubos, bloques y demás accesorios, pueden estar muy calientes. Tome las precauciones mencionadas anteriormente.

## GARANTÍA

Este aparato está garantizado contra cualquier defecto material o de fabricación durante el periodo especificado en la tarjeta de garantía adjunta. Este plazo inicia a partir de la fecha de compra, y dentro de este periodo todas las piezas defectuosas serán reemplazadas gratuitamente siempre que el defecto no sea resultado de un uso incorrecto, accidente o negligencia. Mientras se encuentre bajo garantía las revisiones las debe llevar a cabo el proveedor.

A pesar de la descripción y las especificaciones de los aparatos contenidas en el Manual del Usuario, Techne se reserva por medio de este documento el derecho a efectuar los cambios que estime oportunos tanto en los aparatos como en cualquier componente de los mismos.

Este manual ha sido preparado exclusivamente para los clientes de Techne y nada de lo especificado en este folleto de instrucciones se tomará como una garantía, condición o aseveración de la descripción, comerciabilidad o adecuación para cualquier fin específico de los aparatos o sus componentes.

## MANTENIMIENTO

ESTE APARATO DEBE SER DESMONTADO SOLO Y EXCLUSIVAMENTE POR PERSONAL DEBIDAMENTE CAPACITADO.

EL RETIRAR LOS PANELES LATERALES, FRONTALES O TRASEROS SUPONE DEJAR AL DESCUBIERTO TENSION DE LA RED PELIGROSA.

EL EQUIPO NO CONSTA DE NINGUNA PIEZA DE CUYO MANTENIMIENTO SE PUEDA ENCARGAR EL USUARIO.

En el caso improbable de que experimentara algún problema con su aparato que no pudiera resolver con facilidad, debería ponerse en contacto con su proveedor y devolverlo si fuera necesario. Indique de forma detallada todos los defectos que haya notado y devuelva el equipo en su embalaje original. Techne no aceptará responsabilidad alguna por daños causados en equipos que no estuvieran debidamente embalados para su envío; si tuviera alguna duda, póngase en contacto con su proveedor. Sirvase consultar el Certificado de Descontaminación suministrado con su aparato.

### 1. Limpieza

Antes de limpiar su aparato, desconéctelo SIEMPRE de la fuente de alimentación y permita que se enfríe por debajo de los 50°C.

Este aparato se puede limpiar pasándole un paño húmedo enjabonado. Hágalo con cuidado para evitar que caiga agua dentro del mismo. No utilice limpiadores abrasivos.

### 2. Desconexión en caso de sobretemperaturas

El sistema de desconexión en caso de sobretemperaturas es un dispositivo mecánico sensible (una sacudida mecánica podría desconectarlo).

- Si el calefactor no recibiera alimentación, compruebe el enchufe y el cable de la toma de corriente; a continuación vuelva a ajustar el control del dispositivo (si su equipo lo lleva montado).
- Una desconexión repetida indicaría una avería grave; puede que tenga que devolverle el aparato a su proveedor para su reparación.

### 3. Fusibles

Su aparato está protegido por uno o dos fusibles. Sólo deben cambiarlos personal debidamente capacitado.

Si los fusibles se fundieran repetidamente, esto indicaría una avería grave y puede que tuviera que devolverle el aparato a su proveedor para su reparación.

## INTRODUZIONE

Prima di utilizzare l'apparecchio, leggere tutte le informazioni contenute in questo manuale.

## ATTENZIONE

Le alte temperature sono pericolose: possono causare ustioni gravi all'utilizzatore e possono causare la combustione di materiale infiammabile. La Techne ha posto particolare cura nel progettare questo strumento, al fine di proteggere gli operatori da eventuali pericoli, ma gli utilizzatori devono prestare attenzione ai seguenti punti:

- Utilizzare con attenzione e indossare guanti protettivi.
- Non mettere vicini oggetti caldi o oggetti infiammabili.
- Non azionare il riscaldatore Techne vicino a liquidi infiammabili o benzine.
- Non introdurre nessun liquido all'interno dell'unità.
- In ogni caso Usare Buon Senso.

## SICUREZZA PER L'UTILIZZATORE

Il personale che utilizza l'apparecchiatura Techne deve avere a disposizione la documentazione necessaria al fine di assicurare la loro incolumità.

È importante che solo personale adeguatamente addestrato utilizzi questo apparecchio, in conformità alle istruzioni contenute in questo manuale e nel rispetto delle normative e procedure generali di sicurezza. Se l'apparecchio è utilizzato in modo non specificato da Techne, la protezione fornita dall'apparecchiatura all'utilizzatore potrebbe essere a rischio.

Tutte le unità Techne sono state progettate in conformità ai requisiti internazionali di sicurezza e sono equipaggiate con un interruttore anti surriscaldamento. Su alcuni modelli, l'interruttore è regolabile e dovrebbe essere impostato secondo l'utilizzo. In tutti gli altri modelli l'interruttore è preregolato per proteggere l'unità.

Se si dovesse verificare qualche problema di sicurezza, disconnettere l'apparecchio dalla rete.

## INSTALLAZIONE

1. Tutti gli apparecchi Techne sono forniti di un cavo di alimentazione. Questo può essere integrato nell'apparecchio o separato.
2. Prima di collegare l'apparecchio alla presa di alimentazione, controllare il voltaggio indicato sulla targhetta. La targhetta identificativa si trova sul retro dell'apparecchio. Collegare il cavo di alimentazione in una presa appropriata secondo la tabella seguente.

L'apparecchio deve essere collegato alla messa a terra per assicurare la giusta sicurezza elettrica.

<i>Connessioni</i>	<i>220V-240V</i>	<i>110V-120V</i>
Tensione	Marrone	Nera
Neutro	Blu	Bianco
Terra	Verde/Giallo	Verde



Il fusibile all'interno dell'apparecchio protegge l'apparecchiatura e l'utilizzatore.

Tenere presente che gli apparecchi riportanti sulla targhetta 230 V funzionano a 220V. Gli apparecchi riportanti 120V funzionano a 110V. Comunque, in entrambi i casi la velocità di riscaldamento diminuirà approssimativamente dell'8%.

3. Collegare il cavo elettrico alla presa di corrente sul retro dell'unità.
4. Posizionare l'unità su un luogo adeguato, su una superficie di lavoro piana oppure, se necessario, sotto una cappa aspiratrice, assicurandosi che le prese di aria sulla parte inferiore siano libere da ostruzione.
5. I simboli seguenti, che possono essere collocati in prossimità delle luci di indicazione sul pannello anteriore dell'apparecchio, hanno i seguenti significati:

- I Acceso
- O Spento

### **DOPO L'USO**

Quando avrete terminato di riscaldare i campioni, ricordate che le parti dell'apparecchio – le provette, i loro supporti e gli altri accessori – possono essere bollenti. Seguire le precauzioni elencate in precedenza.

### **GARANZIA**

L'apparecchio è garantito contro ogni difetto del materiale o fabbricazione per il periodo specificato sul certificato di garanzia accluso. Questo periodo decorre dalla data di acquisto, e durante il quale tutte le parti difettose verranno sostituite gratuitamente purché il difetto non sia causato da un uso non appropriato, da cause non imputabili a difetti di fabbricazione o negligenza. L'assistenza durante questo periodo sarà garantita dal fornitore.

Ferme restando la descrizione e le caratteristiche dell'apparecchio contenute nel Manuale d'uso dell'utilizzatore, la Techne si riserva in ogni caso il diritto di effettuare le modifiche che riterrà necessarie all'apparecchio o ai suoi componenti.

Questo Manuale è stato realizzato esclusivamente a vantaggio dei clienti della Techne e in alcun modo potrà essere utilizzato come garanzia, condizione o rappresentazione concernente la descrizione, commercializzazione, adeguamento alle condizioni di utilizzo o altro degli apparecchi o delle sue componenti.

### **MANUTENZIONE**

Questo apparecchio dovrà essere aperto esclusivamente da Personale adeguatamente addestrato. La rimozione dei pannelli laterali, frontali o posteriori può esporre potenzialmente a voltaggi di corrente letali. All'interno dell'apparecchio non ci sono parti manutenibili da parte dell'utilizzatore.

Nell'eventualità che si riscontri un problema con l'apparecchio che non può essere facilmente risolto, si dovrà contattare il proprio fornitore e restituire, se necessario, l'apparecchio. Si prega di specificare nel dettaglio i difetti riscontrati e di ricordare di restituire l'apparecchio nel suo involucro originale. La Techne non si fa carico di alcuna responsabilità per danni subiti dall'apparecchio che non sia stato propriamente imballato per il trasporto; in caso di dubbio, rivolgersi al fornitore. Vedere il Certificato di Decontaminazione fornito con il vostro apparecchio.

### **1. Pulizia**

Prima di pulire il vostro apparecchio, disconnettere sempre la presa di alimentazione e lasciare raffreddare sotto i 50° C. Questo apparecchio può essere pulito passando un panno inumidito con sapone. Si deve prestare attenzione onde prevenire l'ingresso dell'acqua all'interno dell'apparecchio. Non utilizzare per la pulizia sostanze abrasive.

### **2. Disconnessione in caso di surriscaldamento**

In caso di non funzionamento dell'apparecchio, controllare la spina elettrica e il relativo cavo collegati alla rete. Ripetute interruzioni del funzionamento dell'apparecchio indicano un serio malfunzionamento: in questo caso restituire l'apparecchio al fornitore per la riparazione.

### **3. Fusibili**

L'apparecchio è protetto da uno o due fusibili. Questi dovrebbero essere sostituiti solo da personale qualificato. Se i fusibili si bruciano frequentemente ciò indica un malfunzionamento serio e in questo caso si consiglia di contattare il fornitore per le riparazioni.

## WARNING

Poor fluidisation causes hot spots, heater failure, and damage to other parts. Follow instruction book carefully. For correct fluidisation, pay attention to;

### INSTALLATION

Ensure bath is level and air supply is adequate.

### OPERATION

Adjust air valve for even fluidisation.

Do not insert objects larger than recommended.

Ensure objects do not lie in contact with container wall or porous plate.

### MAINTENANCE

Regularly inspect and maintain air filter to eliminate oil vapour in air supply.

### ALUMINA

Should the fluidised bath be stirred for a long period of time under damp or humid conditions, moisture may be absorbed by the alumina which is hygroscopic. To avoid violent fluidisation which occurs when damp alumina is heated above 100°C, operate the bath for a period of approximately 8 hours at 90°C prior to operation at elevated temperatures.

NEVER ADD COLD OR DAMP ALUMINA TO A HOT BATH AS THIS WILL ALSO CAUSE VIOLENT FLUIDISATION WHICH CAN BE DANGEROUS. Allow the bath to cool then add the fresh alumina. If this fresh alumina is a large portion of the charge then dry the whole charge as above.

### FUME EXTRACTION

When used for processing items which may emit toxic or inflammable fumes, it is essential that an adequate fume extraction system be installed. The extraction system must be correctly sized to ensure that any toxic fumes are removed from the working environment.

To eliminate the risk of spontaneous ignition, the concentration of inflammable fumes above the bath and within the exhaust duct work must be kept below the lower explosive limit.

## GENERAL DESCRIPTION

The fluidised bath employs the principle of fluidisation of a mass of finely divided inert particles by means of an upward flow of gas. A state of fluidisation is achieved when the individual particles become microscopically separated from each other by the moving gas. This "fluidised bed" of particles has unusual properties which differ markedly from either those of the gas or of the solid particles. Instead, the fluidised bed behaves remarkably like a liquid, exhibiting characteristics which generally attribute to a liquid state. For example, the fluidised bed can be agitated and bubbled; it always seeks a common level; materials of less density will float while those with densities greater than the equivalent fluidised bed density will sink; and, most important, the heat transfer characteristics between the fluidised bed and a solid interface can have an efficiency approaching that of an agitated liquid.

In addition, the fluidised solid phase has a most unusual physical behaviour, in that its basic characteristics change only slightly over very large temperature ranges; it has no melting point and no boiling point. The lowest temperature available is the liquefaction point of the gas used for fluidisation, while the high temperature level is usable temperature of the inert solid. Various metal oxides with allowable temperatures of over 1700°C are readily available. The metal oxide beds commonly used, (eg aluminium oxide) are non-flammable, non-explosive and non-toxic.

The most commonly used fluidised gas is ordinary compressed air obtained from a blower or compressor. For situations where a non - oxidising atmosphere is required, nitrogen can be utilised and if a reducing atmosphere is required, cracked gas can be employed with a silicon carbide bed.

The unique characteristics of gas fluidised particles is the relatively high rate of heat transfer which yields highly isothermal conditions, as well as excellent heat transfer to solid surfaces. This characteristic is due to the turbulent motion and rapid circulation rate of the solid particles in conjunction with the extremely high solid gas interface area. Therefore, despite the fact that gas solid interfaces normally yield low heat transfer coefficients and the solids normally have low thermal conductivities, the overall heat transfer characteristics of fluidised particles approach those of a liquid.

The combination of excellent heat transfer characteristics and high heat capacity are ideal for attaining rapid stabilisation at an isothermal condition.

Techne industrial fluidised baths use aluminium oxide as the fluidising medium. They have been designed to remove plastic residue from extruder and moulding machine tools, paint build up from paint fixtures, and carry out various heat treatment processes.

The fluidised bed is housed in a circular stainless steel container which has an effluent gas extract duct and fluidised medium drain chute. The container is surrounded by electrical heating elements which are enclosed within thermal insulation. The inner assembly is housed in a square outer case which also supports the electrical and pneumatic control console.

The following control options are available:

A manual control system which consists of a temperature controller, an independent over-temperature cut-out device, a fluidising air pressure interlock, and a manually adjusting fluidising air control valve. Supplied as standard with this, and all other options, is an air pressure regulator and filter assembly.

During operation the correct fluidising air flow must be determined by visually inspecting the surface of the fluidised bath. When the fluidised bath is heated the air within the bath expands; it is therefore

necessary to decrease the amount of air supplied to the bath during the heat up period to ensure that the bath is correctly fluidised at all times.

A control system with automatic air control is also available. This system is designed to automatically adjust the fluidising air flow rate as the bath heats up. This allows the system to be operated without supervision and is useful in applications where it is advantageous to preheat the bath prior to the start of the working day.

The system is programmed to feed a set amount of fluidising air to the bath between room temperature and 200°C. When the bath reaches this temperature, the amount of air feed to the bath is reduced and held at constant value until the temperature of the bath exceeds 400°C, at which point a further adjustment is made.

A non-standard version of this industrial fluidised bath is available for applications where continued treatment of components contaminated by PVC and other halogenated polymers is envisaged. This version is manufactured from materials that resist the effects of corrosion which are experienced when processing the above polymers.

The compressed air supply to the fluidised bath must be clean, dry, and free from oil.

When used for processing items which may emit toxic or inflammable fumes it is essential that an adequate fume extraction system be installed.

The extraction system must be correctly sized to ensure that any toxic fumes are removed from the working environment.

To eliminate the risk of spontaneous ignition the concentration of inflammable fumes above the bath and within the exhaust duct work must be kept below the Lower Explosive Limit. A later section of this manual details the various fume treatment equipment that is available, and how it should be installed and adjusted.

## TECHNICAL SPECIFICATION

Temperature range		50°C to 600°C
Temperature control stability at 450°C		+5°C
Temperature uniformity at 450°C		10°C
Internal dimensions	diameter	450mm
	depth	700mm
	working depth	1100mm
Loading capacity	1/3 of vol.	37 litre
	1/3 of C.S.Area	53020 mm <sup>2</sup> (typically ø259mm).
Typical heat-up time	20°C to 450°C	195 minutes
	20°C to 600°C	330 minutes
Compressed air supply pressure		204-1030kPa (30-150psi)
Air consumption	maximum	320 l/min
	at 450°C	180 l/min
Nominal Heater Power		12KW
Heater type		6 ceramic knuckle heating element
Control system		3 term PID temperature controller + thermocouple sensor.
		Solid state control.
		Independent over temperature cut-out.
Protection systems		Fluidising air interlock
		Door interlock.
		Control circuit fuse.
Electrical safety protection		Power fuse.
		200kg Aluminium Oxide, Part No F0885
Fluidised medium		200kg Aluminium Oxide, Part No F0885
External dimensions	height	1335mm
	width	1125mm
	depth	850mm
Nett weight (less fluidised medium)		226kg
Gross weight (less fluidised medium)		276kg
Electrical supply		See rating plate for details

## INSTALLATION

Mount the fluidised bath in the position where it is to be used. It is important to ensure that the bath is level, otherwise it will fluidise incorrectly. This will lead to the formation of large temperature gradients across the bath which results in premature heater failure and possible damage to the porous plate and inner container assemblies.

Connect any associated fume treatment equipment to the fluidised bath effluent gas extract duct. See section which follows on Fume Cleaning.

Check that the heater isolation resistance (measured from the load side of the solid state relay, to earth) is at least 2.5M ohm before connecting the electrical circuit to the electrical supply. See attached circuit diagram for connection details and the unit rating plate for details of the electrical supply required.

The compressed air supply to the fluidised bath must be clean, dry, and free from oil.

If a manual control option is fitted, close the air flow adjusting valve which is situated on the front of the control console, and connect the air inlet port at the rear of the control console to a suitable dry, clean air supply. Make sure that the pressure delivered to the fluidised bath is between 204kPa (30psi) and 1030kPa (150psi), and that the compressed air line is capable of supplying sufficient air to fluidise the bath (see specification details).

Fill the fluidised bath with a sufficient quantity of aluminium oxide so that, when fluidised, the distance between the top of the aluminium oxide and the top of the bath is 390mm.

Should the fluidised bath be stored for long periods of time under damp or humid conditions, moisture may be absorbed by the alumina which is hygroscopic. To avoid violent fluidisation which occurs when damp alumina is heated above 100°C, operate the bath for a period of approximately 8 hours at 90°C prior to operation at elevated temperatures.

**NEVER ADD COLD OR DAMP ALUMINA TO A HOT BATH AS THIS WILL ALSO CAUSE VIOLENT FLUIDISATION WHICH CAN BE DANGEROUS.** Allow the bath to cool then add the fresh alumina. If this fresh alumina is a large proportion of the charge then dry the whole charge as above.

Set the air pressure regulator, which is situated within the pneumatic section of the control console to 204kPa (30 psi).

Units fitted with the automatic fluidising air control system require no further adjustment. Other systems require adjustment of the air flow adjustment valve which is situated on the fascia of the control console. Adjust the air flow so that the fluidised bed lifts and fluidises evenly across with bubbles of approximately 50mm diameter. It is important to ensure that the bath is correctly fluidised.

If the air flow is too small, uneven fluidisation will result in poor heat transfer and large temperature gradients across the bed. If the air flow is too large the fluidisation will become violent and an excessive amount of fluidising medium will be lost from the bed.

The following table shows the recommended fluidising air flow rates which should be used to achieve the correct level of fluidisation.

Ambient to 200°C	320 l/min
200°C to 400°C	260 l/min
400°C to 600°C	180 l/min

The figures quoted are approximate and may need to be varied depending upon the work load, e.g. the bath may have to be over fluidised to avoid the creation of dead spots above an immersed object. For details of how to adjust the fluidising air flow rate when using the automatic air control system, see Item c) of the Fault Finding Section of this manual.

To safeguard the fluidised bath from damage, two safety features are included in the control console: an adjustable over temperature cut-out which guards against controller failure, and an air pressure switch which inhibits operation if the compressed air supply to the fluidised bath fails. Both of these devices isolate the electrical supply to the heater elements and illuminate the cut-out indicator in a fault condition. The over temperature cut-out is factory preset at 630°C. Under no circumstances should this setting be increased, but lower limits may be set to safeguard particular processes in the fluidisation bath.

If the fluidised bath is to be used to process items that may emit toxic or inflammable fumes, it is essential that an adequate fume extraction system be installed. Details of fume cleaning equipment are contained in the following section of this manual.

The extraction system must be adjusted during initial operation for optimum extraction in line with the following instructions:

- a) Heat the fluidised bath to the operating temperature recommended later in this manual, ensuring that the fluidising air flow rate is adjusted in accordance with the above table.
- b) Switch on the fume extraction system.
- c) Immerse a typical component that is to be treated into the fluidised bath; do not exceed the stated loading capacity, see Technical Specification for details.
- d) Adjust the overall fume extraction rate by adjusting the setting of the damper valves built into the fume extraction system so that adequate fume removal occurs over the surface of the fluidised bath. The velocity of the extraction system should be just sufficient to entrain the maximum quantity of fumes produced above the bath. If high extraction velocity is misused, an excessive amount of fluidising medium will be entrained by the extraction system.
- e) Measure the fume concentration within the fume extraction system using an explosimeter and ensure that the Lower Explosive Limit (LEL) is not exceeded. The fume concentration should be diluted by fitting a dilution tee into the extraction ductwork directly after the fluidising bath. Air may then be induced into the system to dilute the effluent gases. It is recommended that the maximum fume concentration be less than 25% of the LEL.
- f) Measure the fume concentration in the working environment adjacent to the fluidised bath using suitable gas analysis equipment such as "Dräger" tubes, to ensure that any toxic fumes generated within the fluidised bath have been diluted so that the fume concentration is below the threshold limit value. Recommended Threshold Limit Values (TLVs) are available in publications such as the Health and Safety Executive's Guidance Note EH15/76 in the UK, a copy of which is available from Techne on request.



## Fume Ignition

Spontaneous ignition may occur above the surface of the fluidised bath or within the exhaust ductwork if the concentration exceeds the lower explosive limit.

The fume concentration is dependent upon the rate of fume production in the fluidised bath and the level of dilution achieved by entraining air from above the bath or through the dilution tee.

The rate of fume production is dependent upon the type and amount of material being treated and the temperature of the bath.

To ensure that the concentration of inflammable fumes is below the lower explosive limit, ensure that the amount of combustible material immersed in the bath at any one time is within the design capacity of the extraction system.

Ensure that the temperature of the bath is at minimum level to which satisfactory results can be achieved. Increased working temperatures result in increased fume concentration. By way of example, an extraction rate of 2m<sup>3</sup>/min is required to ensure that the fume concentration is below 25% of the lower explosive limit when thermally decomposing 1kg/hr of polythene at 450°C.

To safeguard the fluidised bath from damage, two safety features are included in the control console: an adjustable over temperature cut-out which guards against controller failure, and an air pressure switch which inhibits operation if the compressed air supply to the fluidised bath fails. Both of these devices isolate the electrical supply to the heater elements and illuminate the cut-out indicator in a fault condition. The over temperature cut-out is factory preset at 630°C. Under no circumstances should this setting be increased, but lower limits may be set to safeguard particular processes in the fluidised bath.

## Fume Cleaning

When used for processing items which may emit toxic or inflammable fumes, it is essential that an adequate fume extraction system be installed. A typical schematic diagram of such a system is shown in the appendix; the system consists of the following components:-

Ductwork to connect the fluidised bath extract duct via the various fume treatment equipment to the input of the fume extraction fan. The ductwork should include an air dilution tee, positioned as close as possible to the fluidised bath. The dilution tee enables the fumes within the system to be diluted with air. The ductwork should also include a damper valve which is normally positioned adjacent to the extraction fan. This valve allows the extraction velocity to be reduced. In general the ductwork may be manufactured out of galvanised mild steel; however, in installations where PVC or other halogenated polymers are being processed, it is recommended that stainless steel ducting is used.

The ductwork should be as short as possible and contain the minimum number of bends and horizontal runs so as to reduce the possibility of a blockage.

A cyclone separator should be mounted directly after the dilution tee. The cyclone removes any fluidised medium that may be present in the extracted fumes. The fluidised medium is collected in the cyclone collection bin from where it may be returned to the fluidised bath.

In applications where the components being cleaned are contaminated by polymers which contain inorganic pigments or fillers such as titanium oxide, of a particle size less than 0.005mm diameter which will not be retained by the cyclone, it is recommended that a filtration system be fitted after the cyclone.

In applications where the materials being treated produce acidic vapours during thermal decomposition, it is recommended that a fume scrubber be utilised to ensure that the final fume emission from the plant conforms with local regulations. A caustic dosing system may also be required to ensure that the scrubbing liquid is maintained at an acceptable pH level.

An extraction fan is required in all applications to provide the motive force for the exhaust. In applications where it is not permissible to emit visible smoke from the plant or where local regulations specify the maximum fume concentrations that may be emitted from an exhaust stack, an afterburner may be required. The afterburner heats the fumes to a point where thermal incineration eliminates the visible content of the fumes while reducing the fume concentration. Finally, an exhaust stack is required to direct the treated fumes away from the working environment. The exhaust stack will generally be manufactured out of the same materials as the ductwork system. However, in installations where an afterburner is fitted, the exhaust stack should be manufactured out of insulated stainless steel.

The exact combination of fume treatment components required depends upon the application and local conditions. Technical staff are available to discuss particular applications and offer advice as to which combination is required.

Techne are able to offer the following fume treatment equipment:

Cyclone

Scrubber

Caustic Doser

Extraction Fan

Afterburner

## OPERATION

To set the temperature controller to the required operating temperature, switch on the electrical supply which will illuminate the power and cut-out indicators. Then set the required temperature by using the up and down arrows. Depress the reset switch to initiate the system and extinguish the cut-out indicator.

Your unit is fitted with a Eurotherm 2208L controller and the parameters are factory set and should not be changed.

As the fluidised bath heats up the fluidisation will become more vigorous, due to the expansion of the fluidising air. Units fitted with the automatic fluidising air control system will automatically reduce the air input so as to keep a constant level of fluidisation. Manually operated units must the fluidising air flow, reduced unit the level of fluidisation returns to its original state. The following table indicates the flow rates that are factory set on an auto-air unit.

Ambient to 200°C	320 l/min
200°C to 400°C	260 l/min
400°C to 600°C	180 l/min

The fluidised bath should be operated with the bath lid fitted to reduce heat loss during the heat up period, and to increase the efficiency of the fume extraction system. As the temperature of the fluidised bath approaches the set point, the heater indicator, situated in the temperature controller fascia, will cycle on and off, until the actual temperature reaches the set point temperature.

It may be desirable, depending on the process being carried out in the fluidised bath, to check the actual bath temperature with an independent temperature sensor. Any offset in the temperature may be corrected by adjustment of the temperature controller (an instruction manual for the temperature controller is included with this manual). Further temperature checks may be made at various points within the fluidised bath to ensure good temperature uniformity is being achieved throughout the bed. Slight adjustment of the fluidising air flow rates will reduce any excessive temperature gradients.

**CAUTION:** Care should be taken when handling hot parts which have been removed from a fluidised bath. We recommend that protective clothing (gloves, aprons, and visors, etc) be worn at all times when working with fluidised baths and that the installation and maintenance procedures outlined in this booklet be followed explicate.

## Special operating procedures for use when removing plastic residue

The industrial fluidised bath detailed in this manual is suitable for "burning off" plastic residue from plastic machine tools, and is effective on the full range of polymers. In addition, the bath is also effective on rubber, epoxy resins and various paints. The bath provides a safe, dry, and fast means of removing all plastic residue with the minimum effort.

The process is controlled at a uniform temperature so that distortion of tooling due to uneven heating which occurs when using other heating methods is avoided. Furthermore, as the fluidised bed is non-abrasive, physical damage to parts is minimal.

The cleaning process relies on heat being transferred from the fluidised bed to the immersed tools, the heat degrading the plastic residue. Objects to be cleaned should be supported in a basket or suitable holder for ease of handling and lowered into the fluidised bed. To avoid physical damage and local overheating, it is important to ensure that any items placed in the bed are supported and not allowed to rest either on the porous plate at the bottom of the bed or against the wall of the inner container. The bath should be operated generally in the temperature range of 450°C to 500°C, depending on the polymer to be removed. The process time depends upon the thermal mass of the object, the amount and type of polymer to be removed. During the first two thirds of the process time the polymer is reduced to a tar mix, in this phase all the initially combustible products of the polymer are emitted from the fluidised bath in the form of fumes that must be extracted and treated by suitable fume handling equipment. During the last third of the process time the polymer is reduced to carbon which either burns away or remains loosely bound to the object being cleaned.

Any carbon or incombustible filler that remains on the processed item can be removed by a secondary cleaning operation, either by brushing or some form of water wash.

It is important to ensure that the items being processed do not exceed the maximum loading capacity (see Technical Specification) and that they are loaded into the fluidised bath in such a way that the fluidisation is not impeded.

THE PROCESS RELIES UPON GOOD FLUIDISATION TO ENSURE GOOD HEAT TRANSFER; OVERLOADING OR INCORRECT LOADING OF THE BATH WILL RESULT IN EXTENDED CYCLE TIMES GIVING INFERIOR RESULTS. LOCAL OVERHEATING MAY ALSO OCCUR, GIVING RISE TO PREMATURE HEATER FAILURE AND POSSIBLE DISTORTION OF THE INNER CONTAINER.

The aluminium oxide fluidising medium does not degrade but will need to be replenished due to loss from spillage or entrainment in the exhaust (from where it may be recovered by a cyclone trap).

All articles should be completely cleaned and removed from the bed before shut down. Corrosion of processed parts could be seriously increased if they are left immersed overnight. Furthermore, residual polymer, instead of being burned off in a fluidised state, could percolate down through a static bed and settle on the porous plate to cause a blockage and result in poor fluidisation.

When parts are removed from the bed they should be allowed to cool in air and, whilst still warm, treated to prevent rusting.

It should be noted that some plastics and, in particular, paints contain fillers. These fillers are usually inorganic materials and will not therefore burn when put into a fluidised bath, with the result that the material falls away from the article being cleaned and is retained in the bath, either on the surface or at the base of the bath, depending upon the density of the material involved. If this happens it is recommended that the bath be checked and cleaned at least once a week or more frequently if the bath is used continuously.

The following table details recommended operating temperatures for particular polymers. The temperatures quoted should be used as an initial guide.

The ideal operating temperature will vary depending on the size of the components being cleaned and the amount of material being removed. In general temperatures below 400°C should be avoided to obviate the danger of the polymer melting and sinking to the bottom of the bath where it may block the porous plate. With some large objects it may be desirable to preheat the bath to well above the operating temperature so that the polymer temperature rapidly moves through the melting phase to the burning condition.

Excessive operating temperatures should be avoided as they increase the fume concentration above the bath and may result in the formation of condensed fumes within the extraction system.

<b>Material</b>	<b>Burn-off temperature °C</b>
Nylon	450
Paint	475-575
Polythene	450-500
Polypropylene	425-500
PTFE	500
PVC	450-500
Silicone rubber	550
Ethylene methacrylic	450-480
Polyurethane	440-450
Rubber debonding	350 (debonding)
Polycarbonate	400-425
Polystyrene	450
Organic matter oil/grease	450-500
High density polythene	450
Polyesters	450
Fluoropolymers	500
Styrene	450

## MAINTENANCE

- 1) The aluminium oxide fluidising medium, not being degradable, will only require replacement when losses occur due to attrition and spillage, or contamination with inert pigments, fillers or acidic by products from the cleaning process. Fluidising medium lost through entrainment in the exhaust may be collected in a cyclone trap.

Should the fluidised bath be stored for long periods of time under damp or humid conditions, moisture may be absorbed by the alumina which is hygroscopic. To avoid violent fluidisation which occurs when damp alumina is heated above 100°C, operate the bath for a period of approximately 8 hours at 90°C prior to operation at elevated temperatures.

NEVER ADD COLD OR DAMP ALUMINA TO A HOT BATH AS THIS WILL ALSO CAUSE VIOLENT FLUIDISATION WHICH CAN BE DANGEROUS.

Allow the bath to cool then add the fresh alumina. If this fresh alumina is a large proportion of the charge then dry the whole charge as above.

The fluidised bath may be emptied via the drain chute. The blanking cap should be removed whilst the bed is unfluidised, a suitable container positioned under the chute and the bed fluidised, causing a flow of medium from the chute. This flow may be interrupted at any time by turning off the fluidising air.

- 2) On a daily basis at least, the bed should be cleaned of floating residues by means of a wire mesh hand scoop. This procedure removes carbon char which impairs fluidisation and acts as an absorbent.
- 3) The air line filter supplied with the fluidised bath is self draining. However, it should be kept in good condition by inspection at two weekly intervals and by cleaning the bowls and washing or replacing the filter elements as necessary. With exceptionally dirty or wet air supplies this frequency may have to be increased. Free water or water vapour in the air supply is a notorious source for the production of hydrochloric acid in the bed when PVC is being processed.

In addition, oil vapours in the air supply which reach the porous plate are carbonised within the pores of the plate, quickly causing blockage and consequent poor fluidisation, local overheating, premature heater failure and possible distortion of the inner container.

- 4) The fume extraction system (if used) should be regularly maintained. The cyclone trap collection bin should be emptied at the end of each days use; the collected fluidising medium being returned to the fluidised bath. It is important to ensure that the air tight seal between the cyclone and collector bin is remade.

For maintenance of other fume treatment equipment see the associated maintenance manuals.

SPECIAL MAINTENANCE PROCEDURES TO BE ADOPTED WHEN BURNING OFF PVC OR OTHER HALOGENATED POLYMERS

Burning off PVC (polyvinyl chloride) in a fluidised bath offers one of the most severe conditions of operation. Hydrogen chloride (HCL), liberated on the breakdown of PVC, is absorbed by the bed medium, creating an acidic environment within the bed, especially when the bed also absorbs water from the atmosphere or fluidising air when cold. HCL is extremely corrosive, especially when aerated and wet. In addition, in water it produces water ions which, even in neutral or alkaline solutions, promote corrosion and rusting in steel; witness for example, the corrosive nature of sea water and calcium chloride road de-icer.

Consequently, fluidised beds used for burning off PVC require strict supervision to minimise

corrosion of the bed itself and of the parts cleaned in it, especially if these are of uncoated steel. The purpose of most of the recommended maintenance procedure is aimed at keeping the bed medium clean and free flowing, and free of gums, acids, agglomerates, partly decomposed plastic, char and larger particles. These cleaning processes have the additional benefit of ensuring good fluidisation and this, in turn reduces burn off time, reduces uneven heating of parts and thus distortion, increases heater life by eliminating localised hot-spots, and makes cleaning easier on a regular basis.

The following instructions apply generally to halogenated polymers and specifically to PVC. They are aimed at minimising corrosion of the bath and of immersed metals.

**A) DAILY INTERVALS - at the end of each working day**

- 1) Maintain the working temperature (about 400°C) for half an hour after the last processed batch, to assist removal of corrosive acids from the bath.
- 2) If possible, maintain the temperature of the bath at about 100°C overnight and over weekends and holidays to reduce absorption of water vapour into the batch. Overnight, the residual heat in the bath will usually ensure this.
- 3) Scoop charred plastic residues, clods of media and articles being processed.

**B) WEEKLY INTERVALS - at the end of each working week and before prolonged shut-downs**

- 1) Ensure compliance with instruction A, above.
- 2) Add about 50g (2oz) of powdered mild alkali to the bath and mix in well by maintaining fluidisation for 5 minutes. Suitable alkalis are limestone, dolomite, hydrated or slaked lime, sodium bicarbonate, sodium carbonate, magnesia. The addition of corrosive alkalis such as caustic soda (sodium hydroxide) and quick lime (calcium oxide) should be avoided.

**C) MONTHLY INTERVALS**

- 1) Empty the bath and inspect it for signs of corrosion, especially pitted surfaces and flaking scale. The inside should be wiped out with a rag wetted with 5% washing soda (sodium carbonate) solution.
- 2) Screen the medium through a 50 to 70 mesh sieve before returning it to the cleaned bath. This removes scale, agglomerated medium, char, undegraded polymer and lost parts and helps maintain a good quality of fluidisation.

**D) HALF-YEARLY INTERVALS**

- 1) The bath should be emptied, cleaned, inspected and the medium replaced by a fresh charge.
- 2) Alternatively, if the facilities are available, the medium may be thoroughly washed in several changes of clean water, washed through a 70 mesh sieve, drained, dried and returned to the bath where drying is completed by fluidisation and heating at 150°C, until the medium fluidises in the normal manner. The washing procedure removes acidic residues and accumulated soluble salts and residues.

Symptoms of neglect should be dealt with immediately. These include: pitting of metallic surfaces, formation of lumps of agglomerated medium, accumulation of polymer or polymer filler material, indications of bad or uneven fluidisation, blockage of the fluidising plate and wetness or stickiness of the medium.

**NOTE** A non-standard version of this industrial fluidised bath is available which is manufactured from materials that resist the effects of corrosion experienced when processing items contaminated with PVC and other halogenated polymers. We recommend that this version is utilised in applications where continued use of PVC is envisaged.

## FAULT FINDING

Any service or repair work should only be carried out by a trained electronic or electro mechanical technicians. Untrained personnel should not attempt to dismantle this equipment.

- a) If the cut-out indicator fails to extinguish when the reset switch is depressed, check the temperature of the fluidised bath to determine whether the bath has overheated and operated the temperature cut-out. Check the setting of the over temperature cut-out which is situated within the electrical control console. The over temperature cut-out is factory set to a maximum temperature of 630°C. The cut-out can be re-set by depressing the red knob on the bottom of the cut-out.

To over-ride the door safety switch pull the knob down slightly and out.

Also check that compressed air is being supplied to the fluidised bath and that the air pressure switch is being held in the on position. When operating correctly the air pressure regulator situated within the pneumatic control console should be set at 204k Pa (30psi) and the bath should be fluidised.

- b) If the fluidised bath fails to reach its operating temperature or the heat-up rate decreases, check the level of fluidisation. Where an air flowmeter is fitted, check that the air flow rate agrees with the recommended values, and in any case check that the fluidised bed is evenly fluidised with bubbles of approximately 50mm diameter.

Also check that the heater elements are functioning correctly. Three heater elements are fitted which produce a total heater power of 6kW. The heater elements are individually terminated within the control console (see attached circuit diagrams for wiring details).

To inspect the heater elements, remove the inner container from the outer wrapper, then remove the three layers of thermal insulation that surround the fluidised bath. The heater elements are of the ceramic knuckle type, each element being clamped to the inner container. To remove an element, disconnect the two lead wires from the terminal strip and unbolt the heater clamps.

Before fitting a new heater element, inspect the walls of the inner container to ensure the walls are not deformed. It is vital that the heater element is in close contact with the walls of the container. Any surface irregularities should be treated before a new element is fitted.

Reassemble the unit in reverse order, ensuring that the new heater element is bolted tightly to the inner container.

- c) If the fluidisation within the bath deteriorates, check the compressed air supply and the air filter assembly. Replace the air filter elements if necessary. Where a flowmeter is fitted, check the air flow rates correspond with the recommended values. If an automatic fluidising air control system is fitted and the air flow rates do not agree with the values, re-adjust the system in accordance with the following:-

- i) Ensure that the air pressure regulator is set at 204kPa (30 psi).
- ii) FOR UNITS UP TO ISSUE/5 (with two contactor system).

Adjust the set point of the automatic air control temperature monitor which is located within the electrical console so that both of the air control solenoid valves are closed. The automatic air control temperature monitor is the right hand monitor.

- iii) Adjust the manual valve at the bottom of the pneumatic control console adjacent to the air filter assembly until the indicated air flow rate is approximately 70 l/min.
- iv) Reset the right hand temperature monitor to a temperature of 400°C which will energise the lower solenoid valve. Adjust the central valve until the total indicated airflow rate is approximately 110 l/min.



- v) Reset the central temperature monitor to a temperature of 200°C which will energise the upper solenoid valve. Adjust the upper valve until the total indicated air flow rate is approximately 160 l/min.

OR iib) **For units after Issue/5 (with solid state relay system)**

Adjust the set point of the automatic air control temperature monitor which is located within the electrical console so that both of the air control solenoid valves are closed. The automatic air control temperature monitor is the left hand Eagle 848B controller.

- iii) Adjust the manual valve at the left hand side of the pneumatic control console until the indicated air flow is approximately 70 litres/min.
- iv) Reset the Auto-Air temperature monitor to a temperature of 200°C which will energise the left hand solenoid valve. Adjust the central valve until the total indicated airflow rate is approximately 110 litres/min.
- v) Reset the auto-air temperature monitor to a temperature of 400°C which will energise both solenoid valves. Adjust the right hand valve until the total air flow rate is approximately 160 litres/min.

If the fluidisation in the bath does not produce satisfactory results when using the correct air flow rates, the condition of the porous plate in the base of the fluidised bath must be suspected.

An initial remedy is to operate the fluidised bath at approximately 550°C for a period of at least one hour to allow any accumulated residue in the bath to be decomposed. However, if the fault continues the bath should be emptied and the porous plate examined.

The fluidised bath must only be emptied when the bath is cold.

To empty the bath, use a scoop to remove the alundum, when the unit is fluidised. A small quantity of fluidising medium will remain in the base of the bath; this should be removed using a vacuum cleaner.

When the bath is empty, the stainless steel porous plate may be examined for any sign of damage caused by the accumulation of plastic residue, distortion, or corrosion. Partially blocked areas of the porous plate can be detected if the bath is fluidised with a small quantity of fresh fluidising medium.

**Removal of the porous plate assembly for renewal is as follows:**

- i) Turn bath upside down, remove brass elbow from air pipe.
  - ii) Remove 2 screws, hold thermostat bracket and lift bracket thermostat and over-temperature cut-out sensor clear.
  - iii) Remove nut and washer, secure plate to bottom of chamber, remove plate and insulation.
  - iv) Remove nut and washer in centre of chamber this will release porous plate.
  - v) Turn bath upright remove old plate and fit new one, secure using nut and washer removed in (iv).
  - vi) Reassemble in reverse order when fitting the new porous plate assembly. The felt washer around the air inlet pipe should be re-sealed using a high temperature sealant such as silicate of soda.
- d) For further details of the temperature controller, see the attached Eurotherm temperature controller instruction leaflet.
  - e) To check or replace the thermocouples, disconnect the thermocouple leads from the controller and remove the thermocouple from the thermocouple pocket.

**SPARE PARTS**

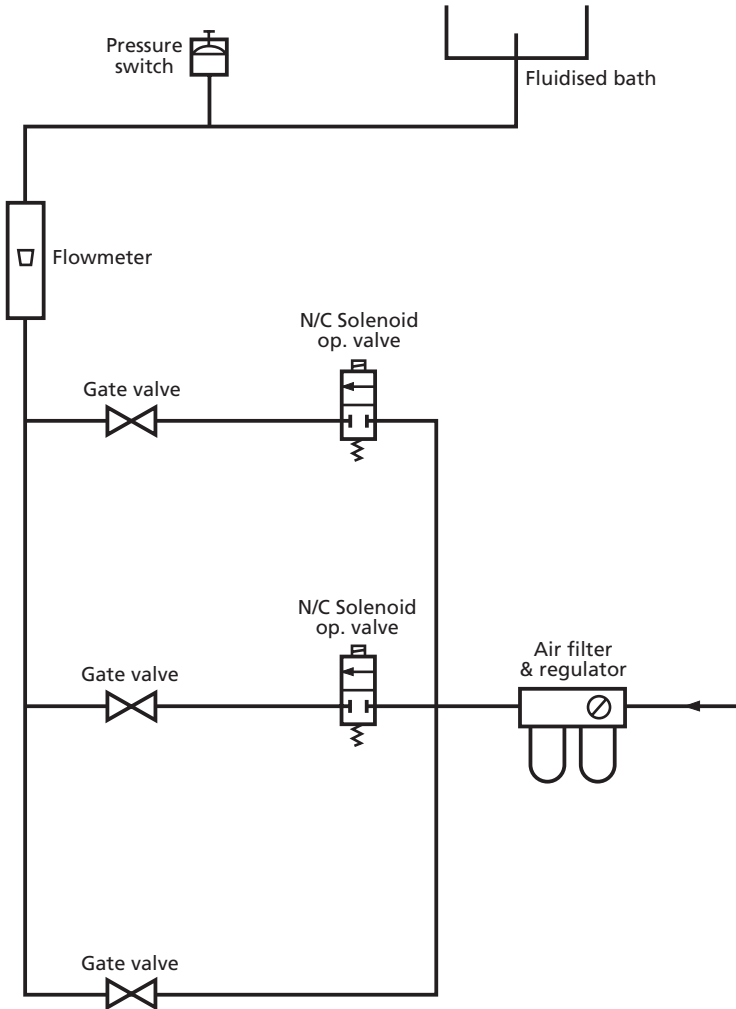
Part Description	Part Numbers for				
	200V	220V	380V	415V	480V
Temperature Controller	6104671	6104671	6104671	6104671	6104671
Overtemperature Cut-Out	6008312	6008312	6008312	6008312	6008312
Thermocouple	6007578	6007578	6007578	6007578	6007578
Contactora 50Hz	6006090	6006090	6005098	6005098	6005098
Transformer	6005680	6005680	N/A	N/A	6005680
Heater	6007767	6007669	6007669	6007668	6007670
Solid State Relay	6500357	6500357	6500356	6500356	6500356
Fuse 2 Amp	6008321	6008321	6008321	6008321	6008321
Fuse 16 Amp	N/A	N/A	N/A	N/A	6008322
Fuse 20 Amp	N/A	N/A	6008323	6008323	N/A
Fuse 35 Amp	N/A	6008324	N/A	N/A	N/A
Fuse 50 Amp	6008291	N/A	N/A	N/A	N/A
Air Pressure Switch	6008325	6008325	6008325	6008325	6008325
Insulation 1	6007589	6007589	6007589	6007589	6007589
Insulation 2	6007591	6007591	6007591	6007591	6007591
Porous plate Assembly	6007593	6007593	6007593	6007593	6007593
Filter Kit (Oil)	6009247	6009247	6009247	6009247	6009247
Filter Kit (Water)	6009248	6009248	6009248	6009248	6009248
Filter/Regulator Assy	6010071	6010071	6010071	6010071	6010071
Filter/Regulator	6009291	6009291	6009291	6009291	6009291

## ACCESSORIES

<b>Part No.</b>	<b>Description</b>
F5967	Lid
F5976	Basket
F5243 *	Extraction Fan 380/415V 50Hz
F5148 *	Extraction Fan 380/415V 50Hz
F6110	Reducing Spigot 150/100mm
AB-100	Afterburner
SR-100	Scrubber
SRD-100	Caustic Doser
CN-100	Cyclone

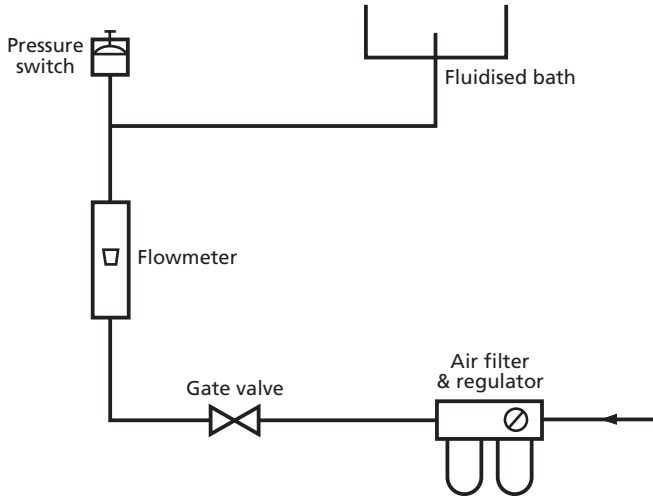
\* Note that when the AB-100 afterburner is fitted, the larger F5148 extraction fan is used in place of the standard F5243 extraction fan.

## AIRWORKS

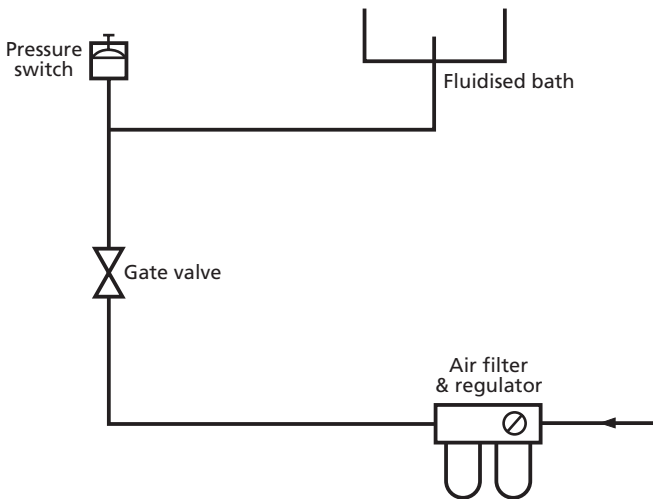


**Fig 1**  
**Auto Air Control**

AIRWORKS



**Fig 2**  
**Manual Control with Flowmeter**



**Fig 3**  
**Manual Control**

CIRCUIT DIAGRAM

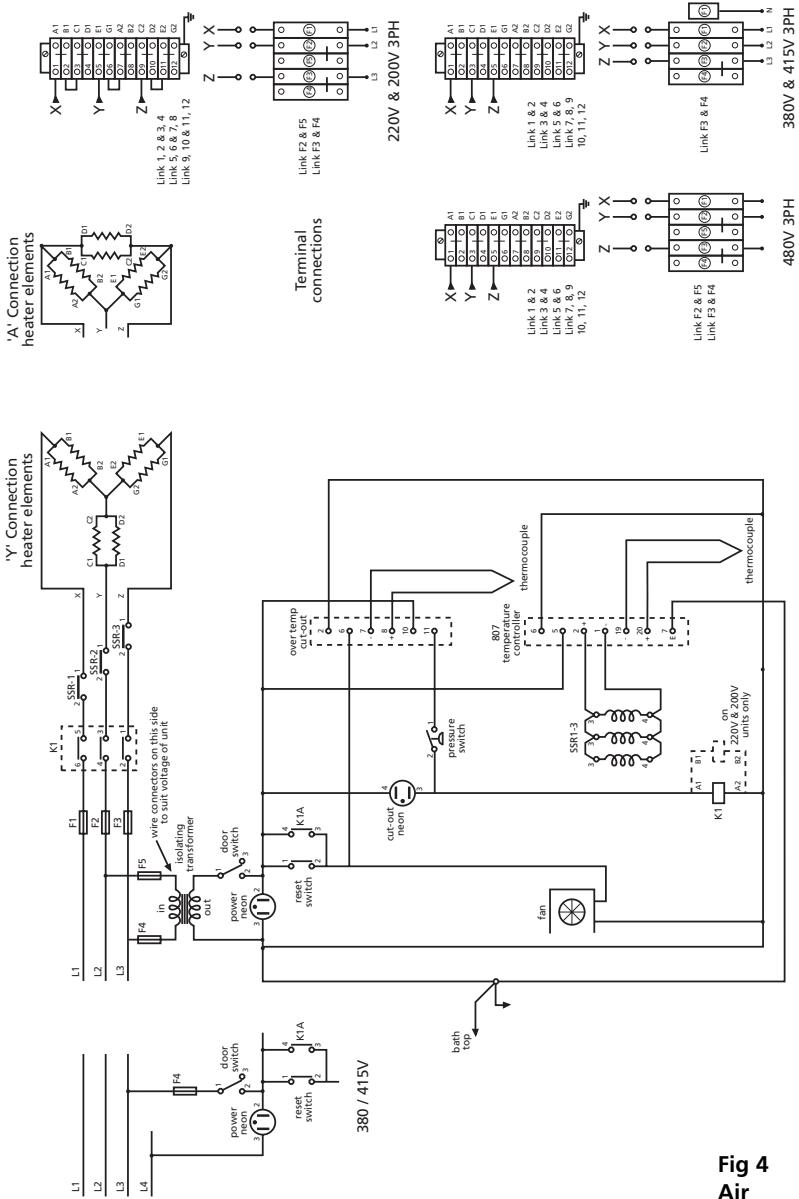
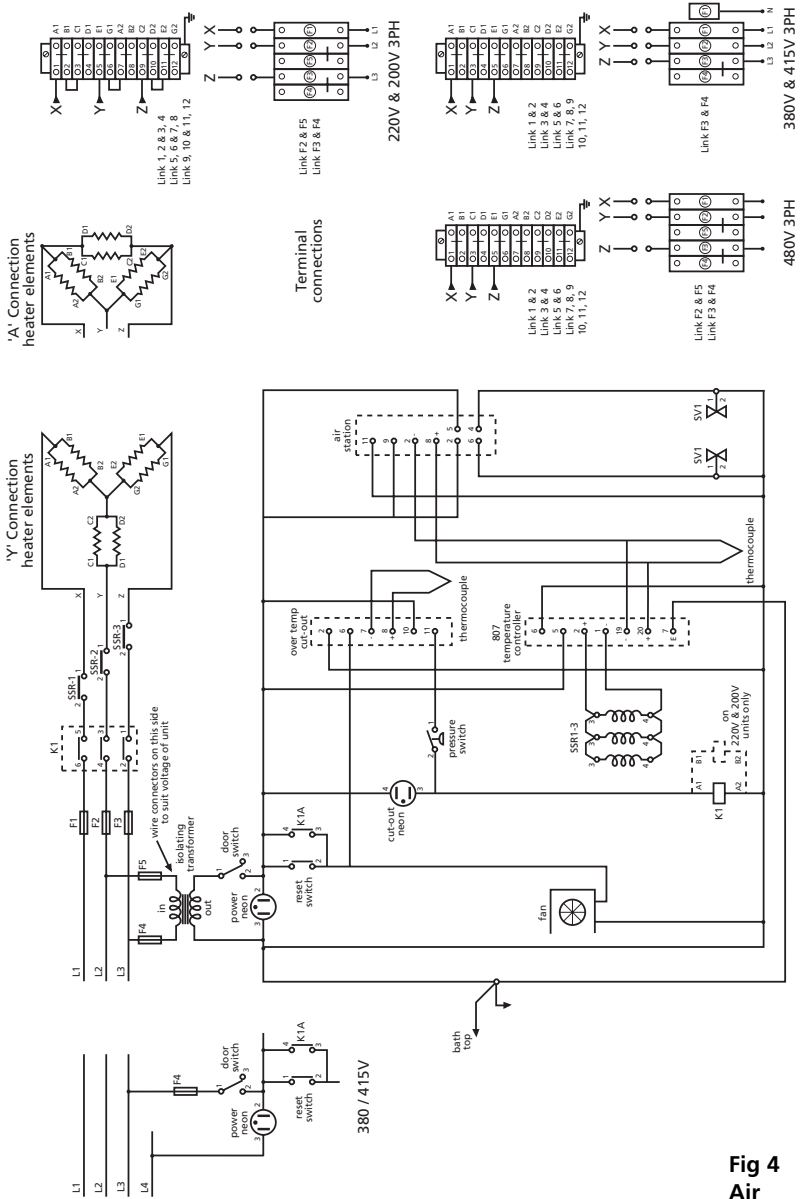


Fig 4  
Air

# CIRCUIT DIAGRAM





Thank you for reading this data sheet.

For pricing or for further information, please contact us at our UK Office, using the details below.



**UK Office**

**Keison Products,**

**P.O. Box 2124, Chelmsford, Essex, CM1 3UP, England.**

**Tel: +44 (0)330 088 0560**

**Fax: +44 (0)1245 808399**

**Email: [sales@keison.co.uk](mailto:sales@keison.co.uk)**

Please note - Product designs and specifications are subject to change without notice. The user is responsible for determining the suitability of this product.