

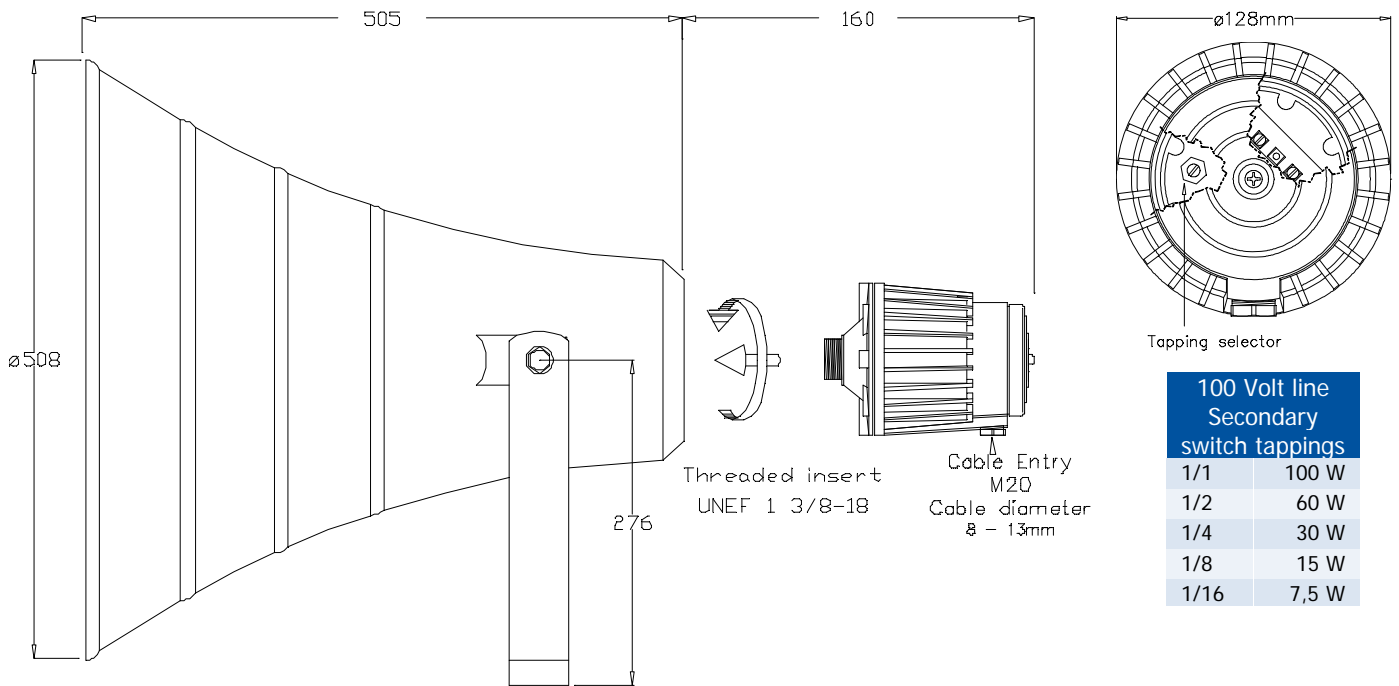

# DNH

## DS(T)-100 / DH-50

ISO 9001 CERTIFIED



100 Volt line Secondary switch tappings	
1/1	100 W
1/2	60 W
1/4	30 W
1/8	15 W
1/16	7,5 W

### Sound pressure levels at 1W/1m

#### SPL vs Freq



### Specifications

Material / Color	Polyester / Aluminum alloy / RAL 7035
Mounting	Bracket / Threaded UNEF 1 3/8 - 18
Termination	Inside screw terminals
Weight	7,7 kg
IP-rating	67
Max. / min. amb. temp	150°C / -50°C
Rated / max. power	100 W / 100 W
SPL 1W/1m	112 dB
SPL rated power	132 dB
Effective freq. range	200 – 5000 Hz
Dispersion (-6dB) 1kHz / 4kHz	50° / 20°
Directivity factor, Q	NA
Options	Impedances, colors, labels

### Installation, Operation and Maintenance Procedures

- DS-100 and DH-50 use UNEF 1 3/8-18 thread.
- Screw DS-100 on to DH-50 using enclosed gasket until the driver is in contact with the gasket, then continue screwing the driver for 180° to 270°. UNEF 1 3/8 -18 thread.
- Remove lid, lead cable trough cable gland and connect cable to terminal.
- Choose required power with tapping selector.
- Tighten cable gland and screw lid back on (1-2 Nm)
- For optimum performance, always use the correct voltage / power and operate within the frequency limits as stated.
- Do not open loudspeaker when energized.
- This loudspeaker is supplied with a 2 year warranty against defective workmanship.

DNH reserves the right to alter specifications without notice





Thank you for reading this data sheet.

For pricing or for further information, please contact us at our UK Office, using the details below.



**UK Office**

**Keison Products,**

**P.O. Box 2124, Chelmsford, Essex, CM1 3UP, England.**

**Tel: +44 (0)330 088 0560**

**Fax: +44 (0)1245 808399**

**Email: [sales@keison.co.uk](mailto:sales@keison.co.uk)**

Please note - Product designs and specifications are subject to change without notice. The user is responsible for determining the suitability of this product.