

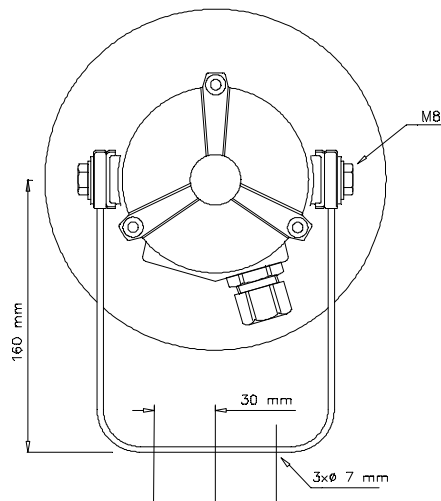

# DNH

## HS-15S(T)

ISO 9001 CERTIFIED

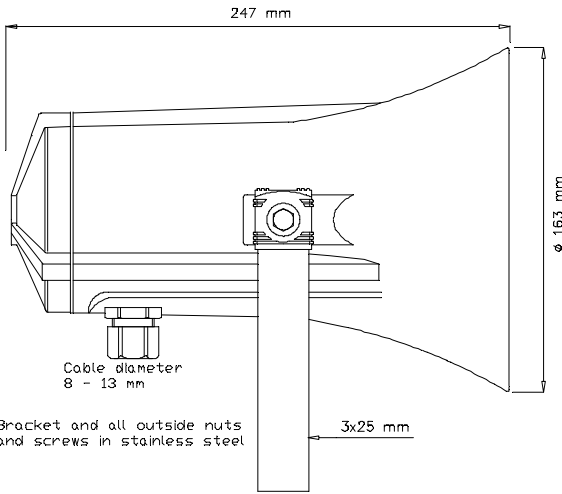

CIRCUIT DIAGRAM

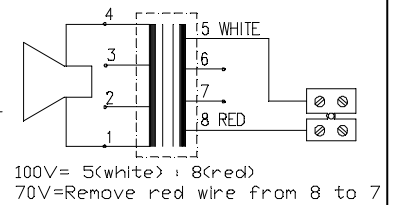

Secondary nominal tappings	
1 : 4	15 W
1 : 3	8,0 W
2 : 4	5,0 W
1 : 2	4,5 W
3 : 4	2,5 W
2 : 3	1,0 W

Sound pressure levels at 1W/1m

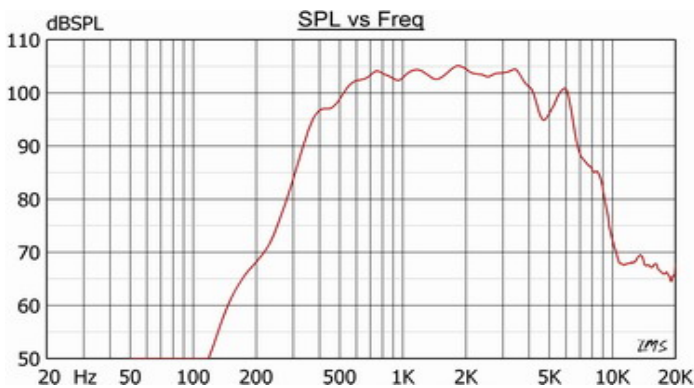

Specifications

Material / Color	Aluminum alloy / RAL 7035
Mounting	Bracket
Termination	Inside screw terminals
Weight w/transformer	2,7 kg
IP-rating	55
Max. / min. amb. temp	150°C / -50°C
Rated / max. power	15 W / 20 W
SPL 1W/1m	107 dB
SPL rated power	118 dB
Effective freq. range	350 – 7500 Hz
Dispersion (-6dB) 1kHz / 4kHz	140° / 50°
Options	Impedances, colors, labels

### Installation, Operation and Maintenance Procedures

- H-15S is designed to withstand sound shocks (maximum 175 dB).
- Fasten the bracket to wall with 1-3 screws and ensure to use all washers in the same position that the loudspeaker is delivered with. (To isolate the main body from the bracket).
- Open the lid back 3 screws. Lead cable through cable gland and connect to terminal. Screw lid back into place, 3 screws with a torque of 2 - 3 Nm to assure the IP rating.
- To change the position of the loudspeaker, please adjust the bracket (by loosening / tightening the screws) as required.
- For optimum performance, always use the correct voltage / power and operate within the frequency limits as stated.
- The aluminum surface of the loudspeaker should be regularly treated with paint at the same interval as with other similar outdoor equipment.
- Do not open loudspeaker when energized.
- This loudspeaker is supplied with a 2 year warranty against defective workmanship.

DNH reserves the right to alter specifications without notice





Thank you for reading this data sheet.

For pricing or for further information, please contact us at our UK Office, using the details below.



**UK Office**

**Keison Products,**

**P.O. Box 2124, Chelmsford, Essex, CM1 3UP, England.**

**Tel: +44 (0)330 088 0560**

**Fax: +44 (0)1245 808399**

**Email: [sales@keison.co.uk](mailto:sales@keison.co.uk)**

Please note - Product designs and specifications are subject to change without notice. The user is responsible for determining the suitability of this product.