

Aspirator with trap flask

FTA-2i

Operating instructions



1.	About this edition of user manual.....	2
2.	Safety Precautions	3
3.	General information	4
4.	Getting started.....	5
5.	Operation	7
6.	Specifications	8
7.	Guarantee and service	10
8.	EU Declaration of Conformity	11

1. About this edition of user manual

The instructions applies to following versions of mini-rotator:

- **FTA-2i** version V.1GW

2. Safety Precautions

The following symbols mean:



Caution!

Make sure you have fully read and understood the present instructions before using the equipment. Please pay special attention to sections marked by this symbol.

GENERAL SAFETY

- Use only as specified in the provided operating instructions.
- The unit should be saved from shocks or falling.
- Store and transport the unit at ambient temperatures between -20°C and +60°C and maximum relative humidity of 80%.
- After transportation or storage keep the unit under room temperature for 2-3 h before connecting to electric circuit.
- Before using any cleaning or decontamination methods except those recommended by the manufacturer, check with the manufacturer that the proposed method will not damage the equipment.
- Do not make modifications to the design of the unit.

ELECTRICAL SAFETY

- Connect only to external power supply with voltage corresponding to that on the serial number label.
- Ensure that the switch and the plug are easily accessible during use.
- Use only the external power supply provided with this product.
- Do not plug the unit into an ungrounded power socket, and do not use an ungrounded extension lead.
- If liquid penetrates into the unit, disconnect it from electric circuit and have it checked by a repair and maintenance technician.
- Disconnect the unit from electric circuit before moving.
- Do not operate the unit in premises where condensation can form. Operating conditions of the unit are defined in the Specification section.

DURING OPERATION

- Do not operate the unit in environments with aggressive or explosive chemical mixtures. Please contact manufacturer for possibility of unit operation in specific atmosphere.
- It is not allowed to use aggressive organic compounds, chlorinated solvents, and strong conjugated acids for operation with the unit.
- Do not operate the unit if it is faulty or has been installed incorrectly.
- Do not use outside laboratory rooms.
- Do not leave the operating unit unattended.

BIOLOGICAL SAFETY

- It is the user's responsibility to carry out appropriate decontamination if hazardous material is spilt on or penetrates into the equipment.
- Empty the trap flask when the liquid level reaches maximum. Take necessary precautions utilizing waste liquid in accordance with general laboratory standards.

3. General information

FTA-2i aspirator with trap flask has been designed for liquid removal from micro-test tubes (e.g. for supernatant removal during DNA/RNA extraction), ELISA plates (e.g. performing several repeated well washing cycles), cell culture flasks (cell media exchange and washing during cell growth) and other vessels during various laboratory techniques using standard tips attached to the universal adapter MA-U or using our new Hand Operator Set **HAS-1** which widely broads the application possibilities of **FTA-2i** operation for user. The new accessory **HAS-1** consists of handheld vacuum controller with different attachments as like 8-channel adapter with stainless steel tips, 8-channel adapter for 200 µl tips, single channel adapter for 200 µl tips and others.

FTA-2i aspirator operation principle is based on creating negative pressure in a trap flask using a built-in micro-compressor. The trap flask is connected with a collection tip by a silicone pipe. Liquid is removed from the vessels when the tip touches the liquid surface. Holder for 2 tubes (e.g. for hydrochloric acid solution and distillate) necessary for collecting tip washing and storing for re-use is conveniently situated at aspirator right hand side.

Microbiologic suction filter eliminates risks of contamination caused by bacteria, viruses, and infected particles from samples. Such contamination can be distributed by suction pump or central vacuum units. Microbiological suction filter is hydrophobic and has very high contamination removal bacterial efficiency – up to 99.99% of particles bigger than 0.027 micrometres (e.g. Hepatitis A, B and C, HIV, etc.).

In order to prolong performance and efficiency of device it is not allowed to use aggressive organic compounds (e.g. phenol) and strong conjugated acids (e.g. guanidine) for aspiration. Please, contact manufacturer in case of any questions regarding operation of device.

4. Getting started

4.1. Unpacking.

Remove packing materials carefully and retain them for future shipment or storage of the unit. Examine the unit carefully for any damage incurred during transit. The warranty does not cover in-transit damage.

Warranty covers only the units transported in the original package.

4.2. Complete set. Package contents:

4.2.1. Standard set.

- **FTA-2i** Aspirator..... 1 pce.
- Universal adapter **MA-U** 1 pce.
- Trap flask 1 pce.
- Hydrophobic filter 1 set
- Aspiration tips, 200 µL.....50 pcs.
- Aspiration tips, 1000 µL10 pcs.
- Holder tubes (2 ml)..... 5 pcs.
- Spare filter..... 1 set
- External power supply 1 pce.
- Operating manual, declaration of conformity.....1 copy
- Sensor..... 1 pce

4.2.2. Optional accessories

- **MA-8**, 8-channel aspiration tip with holder on request
- **HAS-1**, hand operator set with **SH-6** stand..... on request

4.3. Setup

- Place the unit on an even horizontal working surface.
- Install the trap flask (fig. 1/1) on the unit.
- Screw on the lid with the sensor needles and valves for tubing, to trap flask.



Note! Filter is attached on the rear panel of the unit, before vacuum source. Install the filter with "IN" marking pointing **away from the unit** (fig. 2/1).

- Assemble the filter set (fig. 2/1 – 2/5 and fig. 3/1 – 3/2) and connect it to the port on the rear panel of the unit (fig. 5/1);
- Attach the fitting (fig. 3/1) of the silicone air tubing (fig. 3/2) to the valve with **white** ring on the lid.
- Ensure that the filter assembly is tightly fixed in its slot.
- Assemble the aspiration tip set (fig. 4/1 – 4/3).
- Attach the fitting (fig. 3/3) of the silicone tubing for liquids (fig. 3/4 and fig. 4/3) to the valve with the **blue** ring on the lid.
- Insert the sensor (fig. 3/5) in the lid of the unit, connect the sensor cable to the port on the rear panel of the unit (fig. 5/3).
- Connect the external power supply to the port on the rear panel of the unit (fig. 5/4) and set the unit on an even horizontal surface, so that the external power supply and the power switch are easily accessible.

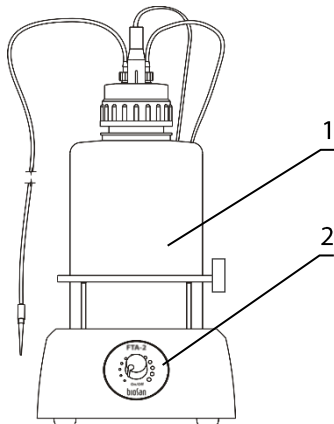

Fig. 1. FTA-2i front view

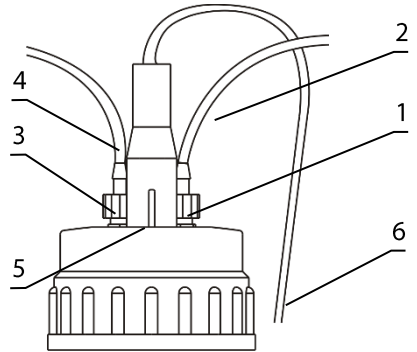

Fig. 3. Unit lid with sensor slot

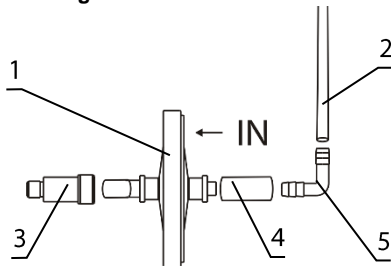

Fig. 2. Filter set

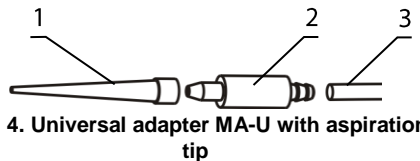

Fig. 4. Universal adapter MA-U with aspiration tip

4.4. Optional **MA-8** aspiration tip setup.

- Replace the tubes and aspiration tip from the holder on the right side of the unit (fig. 1) with **MA-8** storage holder (fig. 6/2);
- Remove the aspiration tip (fig. 4/1) from the **MA-U** adapter and connect the **MA-8** aspiration tip (fig. 6/1).

4.5. Optional **HAS-1** hand operator setup.

- Unscrew the **MA-U** (fig. 4) from the aspiration tube (fig. 4/3) and connect the **HAS-1** hand operator (fig. 6/3) by screwing in the fitting.

5. Operation

- 5.1. Connect the external power supply to the mains.
- 5.2. Switch the **Power** switch, located on the rear panel of the unit (fig. 5/2), to the position **I** (on).
- 5.3. Using the regulator knob on the front panel of the unit (fig. 1/2), regulate the aspiration intensity, clockwise direction increases power, counter clockwise – decreases.
- 5.4. Touch the solution surface with the aspiration tip (fig. 4/1) to remove liquid from a test tube.



Caution!

During operation do not allow the collected buffer level to exceed the maximum level. Empty the trap flask when the liquid level reaches maximum (according to p. 4.6).



Note.

When collected buffer level exceeds the maximum level, sensor turns off the motor and turns on sound and light warning signals.

- 5.5. After finishing the operation, switch off the **Power** switch (fig. 5/2) and disconnect the external power supply unit from electric circuit.
- 5.6. **Emptying the trap flask.**

Turn off the unit. Unscrew the lid. Empty the trap flask. Take necessary precautions in utilizing waste liquid in accordance with general laboratory standards. Return the trap flask on the unit. Screw back on the lid.

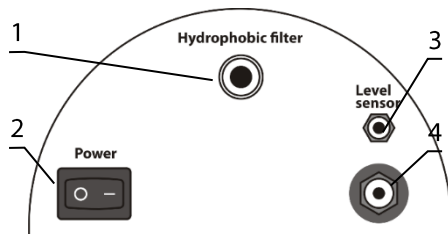

Fig. 5. Rear panel of the unit.

6. Specifications

The unit is designed for operation in cold rooms, incubators and closed laboratory rooms at ambient temperature from +4°C to +40°C in a non-condensing atmosphere and maximum relative humidity 80% for temperatures up to 31°C decreasing linearly to 50% relative humidity at 40°C.

Grant is committed to a continuous programme of improvement and re-serves the right to alter design and specifications of the equipment without additional notice.

- 6.1. Aspiration speed
 - Airup to 10 L/min
 - Liquidup to 27.8 mL/s
- 6.2. Vacuum regulation yes
- 6.3. Working vacuum pressure from -200 to -800 mbar
- 6.4. Sensor type invasive
- 6.5. Overflow protection motor stops, sound and light signal
- 6.6. Trap flask 2 L, polypropylene
- 6.7. Filtration hydrophobic microbiologic filter 2200/02
eliminates risk of contamination from the trap flask with bacteria, viruses and infected particles
- 6.8. Filter pore diameter 0.027 µm
- 6.9. Input current / Power consumption 12V, 1 A / 10.8 W
- 6.10. External power supply input AC 100-240 V, 50/60 Hz; output DC 12 V
- 6.11. Dimensions (WxDxH) 185x290x390 mm
- 6.12. Weight* 1.85 kg

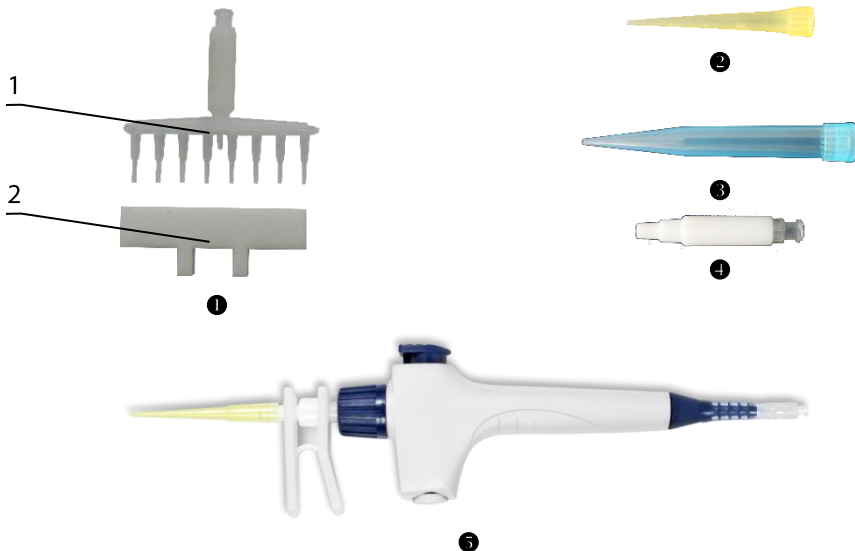

Fig. 6.

* Accurate within ±10%.

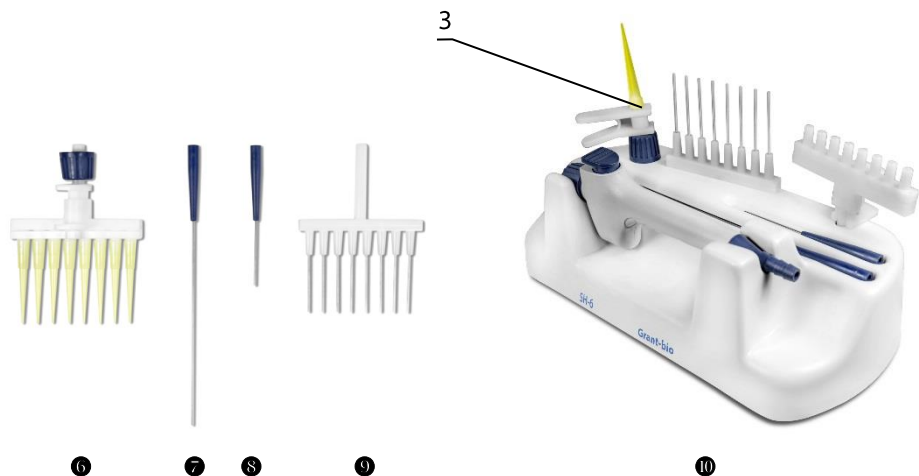

Fig. 6. (cont.)

Optional accessories	Description
Fig. 6/①	MA-8 , 8-channel aspiration tip with holder
Fig. 6/⑤-⑩ and 6/3	HAS-1 , hand operator set. Set includes: Handheld vacuum controller with adapter ⑤, 1-channel adapter (with ejector) for 200 µL tips (3), 1-channel adapter with 40 mm stainless steel pin ⑧, 1-channel adapter with 125 mm stainless steel pin ⑦, 8-channel adapter (with ejector) for 200 µL tips ⑥, 8-channel adapter with 35 mm stainless steel pin ⑨ Stand SH-6 for hand operator parts ⑩

Replacement parts	Description
Fig. 6/②	Aspiration tip, 200 µL
Fig. 6/③	Aspiration tip, 1000 µL
Fig. 4/2 and 6/④	MA-U , universal adapter for 200/1000 µL single use tips
Fig. 1/1	Trap flask (2 L) with lid, cup insert and sealer
Fig. 2/1	Hydrophobic filter
Fig. 2/3	Adapter between the unit and the filter
Fig. 2/5	90° angle fitting
Fig. 3/1 and 4/3	Fittings for tubing on the lid
Fig. 3/5	Sensor cable
Fig. 2/2, 3/4, 4/4	Silicone tubing set
Fig. 6/1	8-channel aspiration tip for MA-8

7. Guarantee and service

- 7.1. **Guarantee.** When used in laboratory conditions and according to these working instructions, this product is guaranteed for TWO YEARS against faulty materials or workmanship. For full details of the Grant Bio Warranty policy, please contact Grant Instruments.
- 7.2. **Service.** For service, return for repair to our Service Department in the UK or, in other countries, to our distributor.
- 7.3. **Cleaning & disinfection.** Standard ethanol (75%) or other cleaning agents recommended for cleaning of laboratory equipment can be used for cleaning and decontamination of the plastic parts of the unit. To clean internal parts of the silicone tubing and tips, use only distilled water, no less than 0.5 L.
- 7.4. **Autoclave.** The following unit parts are autoclavable at 121°C and 1 atm.:

- Flask trap (recommended time 55 minutes);
- Lid, fittings and tubing (except the filter, recommended time 15 min).



Note. Silicone tubing deteriorate after frequent autoclaving and should be replaced.

- 7.5. Change tubing every 6 months. See table in the Specifications section for the necessary catalogue number.
- 7.6. It is necessary to replace the filter as soon as it accumulates visible traces of dirt, or when the liquid is sucked into it. Maximum working time for the filter is 30 days. When working with infected materials, replace the filter immediately after finishing the procedure to prevent the spread of infection. To order the filter, see table in the Specifications section for the necessary catalogue number.
- 7.6.1. **Changing the filter.** Remove the filter with the inlet pipe (Fig. 2) by detaching it from adapter between the unit and the filter. Insert a new filter and reconnect the adapters.



Caution! Observe the orientation of the filter according to figure 3. The “IN” marking should be on the side that is away from the unit.

- 7.7. Troubleshooting:

Problem	Possible reason	Troubleshooting
Unit not working	<ol style="list-style-type: none"> 1. No power 2. Trap flask full 3. Sensor not connected properly 	<ol style="list-style-type: none"> 1. Check external power supply connector (fig. 5/4) 2. Sensor shut down the motor. Empty the trap flask according to 4.6. 3. Check sensor cable and attachments
Aspiration slow or absent	<ol style="list-style-type: none"> 1. Aspiration intensity set to small 2. Breach in the system 3. Dirt in the tubing 4. Liquid in the filter 	<ol style="list-style-type: none"> 1. Turn the regulator knob clockwise to increase aspiration. 2. Check all the tubing and fittings. Tightly close the lid of the unit 3. Clean the tubing, see 6.3. 4. Replace the filter
Sensor activated, but the flask is not full	<ol style="list-style-type: none"> 1. Foam in the trap flask activated the sensor 	<ol style="list-style-type: none"> 1. Do not use the unit on foaming liquid or use antifoaming agent.

EU Declaration of Conformity

Unit type	Trap flask aspirators
Models	FTA-1, FTA-2i
Serial number	14 digits styled XXXXXYYMMZZZ, where XXXXX is model code, YY and MM – year and month of production, ZZZZ – unit number.
Manufacturer	SIA BIOSAN Latvia, LV-1067, Riga, Ratsupites str. 7/2
Applicable Directives	EMC Directive 2014/30/EU LVD Directive 2014/35/EU RoHS2 2011/65/EU WEEE 2012/19/EU
Applicable Standards	<u>LVS EN 61326-1: 2013</u> Electrical equipment for measurement, control and laboratory use. EMC requirements. General requirements. <u>LVS EN 61010-1: 2011</u> Safety requirements for electrical equipment for measurement, control, and laboratory use. General requirements.

We declare that this product conforms to the requirements of the above Directives



Signature

Svetlana Bankovska
Managing director

19.07.2016.

Date



Signature

Aleksandr Shevchik
Engineer of R&D

19.07.2016

Date



Thank you for reading this data sheet.

For pricing or for further information, please contact us at our UK Office, using the details below.



UK Office

Keison Products,

P.O. Box 2124, Chelmsford, Essex, CM1 3UP, England.

Tel: +44 (0)330 088 0560

Fax: +44 (0)1245 808399

Email: sales@keison.co.uk

Please note - Product designs and specifications are subject to change without notice. The user is responsible for determining the suitability of this product.