



Fast response monitor for the detection of a target gas

SPM



Advantages

- Fast response monitor specific to target gas only
- Gas sensitivity to ppb levels with physical evidence
- Minimum maintenance and no dynamic calibration
- Customized for harsh industrial environments
- More than 50 gas calibrations available

Applications

- Outdoor locations
- Corrosive areas
- Remote sampling areas
- Gas storage areas
- Survey work
- Perimeter/fencelines
- Ventilation and exhaust systems

Options

- Z-purge system
- Duty cycle
- ChemKey™
- RS422
- Remote reset
- Portable
- Extended sample
- Heater option
(operate from -20°C to $\pm 40^{\circ}\text{C}$)

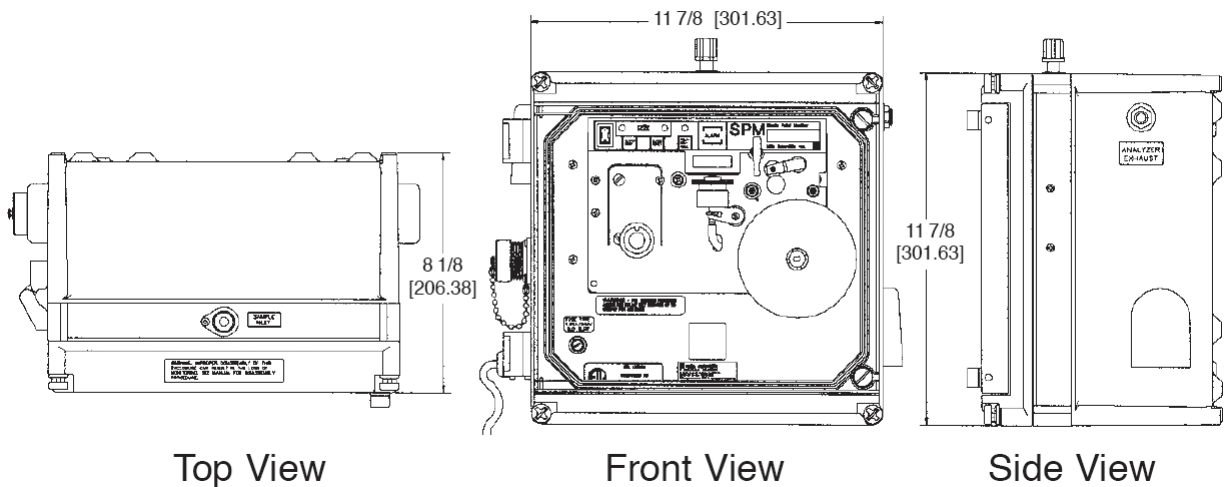

Technical Specification



Specifications

Detection Technique	Chemcassette® Detection System
Alarm Point	Dual level alarms typically set at 1/2 TLV and TLV
Response Time	As fast as 10 seconds
Alarm Indication	Local audio/visual alarms; remote capability optional
Signal Outputs	SPDT concentration alarm relays; SPDT fault relay; 4-20 mA; digital display
Relay Rating	120VAC@10amps; 240VAC@5amps; 48VDC@5amps
Operating Temperature Range	32° to 104°F; 0° to 40°C (basic unit); heating/cooling optional
Power Requirements	115/230 VAC 50/60 Hz, battery operation optional
Enclosure	NEMA 4X fiberglass (basic unit)
Dimensions	12"(H) x 12"(W) x 7"(D) (30.5 x 30.5 x 17.8 cm) (basic unit)
Weight	Up to 25 pounds, depending on option installed

Note: options may vary the specifications

Detectable Gases Range

Amines

Ammonia (NH ₃)	2.6-75.0 ppm
Ammonia (NH ₃)-II	2.6-75.0 ppm
Dimethylamine (DMA)	0.1-6 ppm
n-Butylamine (n-BA)	0.4-12 ppm
Methylene Dianiline (MDA)	3-60 ppb
p-Phenylene Diamine (PPD, PPDl)	2-60 ppb
Toluene Diamine (TDA)	4-60 ppb
Trimethylamine (TMA)	1.1-30.0 ppm

Diisocyanates

(CHDI, HDI, HMDI, IEM, IPDI, MDI, NDI, PPDl, TDI, TMDI, TMXDI, XDI)	2-60 ppb
---	----------

Hydrazines

MMH*	3-30 ppb
N ₂ H ₄ *	20-300 ppb
UDMH*	5-30 ppb

Hydrides

Arsine (AsH ₃)	15-150 ppb
Diborane (B ₂ H ₆)	31-300 ppb
Disilane (Si ₂ H ₆)	1.5-15 ppm
Germane (GeH ₄)	141-600 ppb
Hydrogen Selenide (H ₂ Se)	20-150 ppb
Phosphine (PH ₃)	32-900 ppb
Silane (SiH ₄)*	0.5-15 ppm
Stibine (SbH ₃)	20-300 ppb
tert-Butylarsine (TBA)	15-150 ppb
tert-Butylphosphine (TBP)	60-900 ppb

Hydrogen Cyanide (HCN)

	1.1-30.0 ppm
--	--------------

Hydrogen Sulfide (H₂S)*

	1.1-30.0 ppm
--	--------------

Mineral Acids

Hydrogen Bromide (HBr)*	0.3-9.0 ppm
Hydrogen Chloride (HCl)*	0.5-15.0 ppm
Hydrogen Fluoride (HF)	0.6-9.0 ppm
Hydrogen Iodide (HI)	0.3-9.0 ppm
Nitric Acid (HNO ₃)	0.2-6.0 ppm
Sulfuric Acid (H ₂ SO ₄)	26-750 ppb

Oxidizers

Bromine (Br ₂)	11-300 ppb
Chlorine (Cl ₂)	0.05-1.5 ppm
Chlorine (Cl ₂)	-II 0.05-1.5 ppm
Chlorine Dioxide (ClO ₂)	11-300 ppb
Hydrogen Peroxide (H ₂ O ₂)*	0.1-3 ppm
Nitrogen Dioxide (NO ₂)*	0.3-9.0 ppm
Ozone (O ₃)	31-300 ppb

Phosgene (COCl₂)*

	11-900 ppb
--	------------

Sulfur Dioxide (SO₂)*

	0.2-6.0 ppm
--	-------------

* other ranges available



Thank you for reading this data sheet.

For pricing or for further information, please contact us at our UK Office, using the details below.



UK Office

Keison Products,

P.O. Box 2124, Chelmsford, Essex, CM1 3UP, England.

Tel: +44 (0)330 088 0560

Fax: +44 (0)1245 808399

Email: sales@keison.co.uk

Please note - Product designs and specifications are subject to change without notice. The user is responsible for determining the suitability of this product.