



**Sensepoint  
Gas Detectors**



# Safety

Ensure that this Technical Manual is read and understood BEFORE installing/operating/maintaining the equipment.

Pay particular attention to Warnings and Cautions.

All document Warnings are listed here and repeated where appropriate at the start of the relevant chapter(s) of this Technical Manual. Cautions appear in the sections/sub-sections of the document where they apply.

## WARNINGS

***Sensepoint is designed for installation and use in Zone 1 or 2 hazardous areas in Europe. Installation must be in accordance with the recognized standards of the appropriate authority in the country concerned.***

***Before carrying out any work ensure local regulations and site procedures are followed. Appropriate standards must be followed to maintain the overall certification of the detector.***

***Access to the interior of the detector, when carrying out any work, must only be conducted by trained personnel. Switch off and isolate the power supply to the detector when access is required. Take any necessary precautions to prevent false alarms.***

***Never attempt to open a junction box/enclosure or replace/refit the sensor when flammable/toxic gas is present.***

***The detector must be earthed for electrical safety and to limit the effects of radio interference. An earth point is provided inside the unit. Ensure that all screens/armor are grounded at a single earth star point at the controller or detector - BUT NOT BOTH - to prevent false alarms due to earth loops.***

***Take care when handling sensors as they may contain corrosive solutions. Do not tamper or in any way dis-assemble the sensor. Do not expose to temperatures outside the recommended range. Do not expose sensor to organic solvents or flammable liquids.***

***At the end of their working life, sensors must be disposed of in an environmentally safe manner. Disposal should be according to local waste management requirements and environmental legislation. Alternatively, sensors may be securely packaged and returned to Honeywell Analytics clearly marked for environmental disposal. Electrochemical cells should NOT be incinerated as they may emit toxic fumes.***

***When replacing the gas detector's junction box ensure that the correct gas label is affixed to the replacement enclosure.***

# Information

Honeywell Analytics can take no responsibility for installation and/or use of its equipment if this is not done in accordance with the appropriate issue and/or amendment of the Technical Manual.

The reader of this Technical Manual should ensure that it is appropriate in all details for the exact equipment to be installed and/or operated. If in doubt, contact Honeywell Analytics for advice.

The following types of notices are used throughout this Technical Manual:

## **WARNING**

***Identifies a hazardous or unsafe practice which could result in severe injury or death to personnel.***

---

***Caution*** ***Identifies a hazardous or unsafe practice which could result in minor injury to personnel, or product or property damage.***

---

*Note* *Identifies useful/additional information.*

Every effort has been made to ensure the accuracy of our documents, however, Honeywell Analytics can assume no responsibility for any errors or omissions in our documents or their consequences.

Honeywell Analytics greatly appreciates being informed of any errors or omissions that may be found in the contents of any of our documents.

For information not covered in this document, or there is a requirement to send comments/corrections about this document, please contact Honeywell Analytics.

Honeywell Analytics reserve the right to change or revise the information supplied in this document without notice and without obligation to notify any person or organization of such revision or change. If information is required that does not appear in this document, contact the local distributor/agent or Honeywell Analytics.

# Contents

<b>Safety</b>	<b>3</b>
<b>Information</b>	<b>4</b>
<b>Introduction</b>	<b>7</b>
General	8
<b>Installation</b>	<b>9</b>
Location	10
Tools	11
Dimensions	11
Mounting	12
Electrical	13
Cabling	13
Power	15
Wiring	15
All Detectors EXCEPT Oxygen	17
Oxygen Detectors ONLY	17
Accessories	19
Fitting an Outer Filter	19
<b>Maintenance</b>	<b>20</b>
Operational Life	21
Sensor Replacement	21
Junction Box Replacement	23
Changing the Outer Filter	26
Fault Finding	27
<b>Parts</b>	<b>28</b>
Sensors	28
Other Parts	29
Accessories	29
<b>Specifications</b>	<b>30</b>
General	30
Detectable Gases	30
Electrical	31
Physical	31
Certification	31
Applicable Standards	31
Environmental	31



# Introduction

The **Sensepoint** gas detector consists of a certified enclosure fitted with a replaceable certified gas sensor that can be used to detect gas indoors or outdoors in ATEX certified hazardous areas in Europe, and also in safe areas. It is protected against water and dust ingress to IP65 (IP66 with Weather housing fitted).

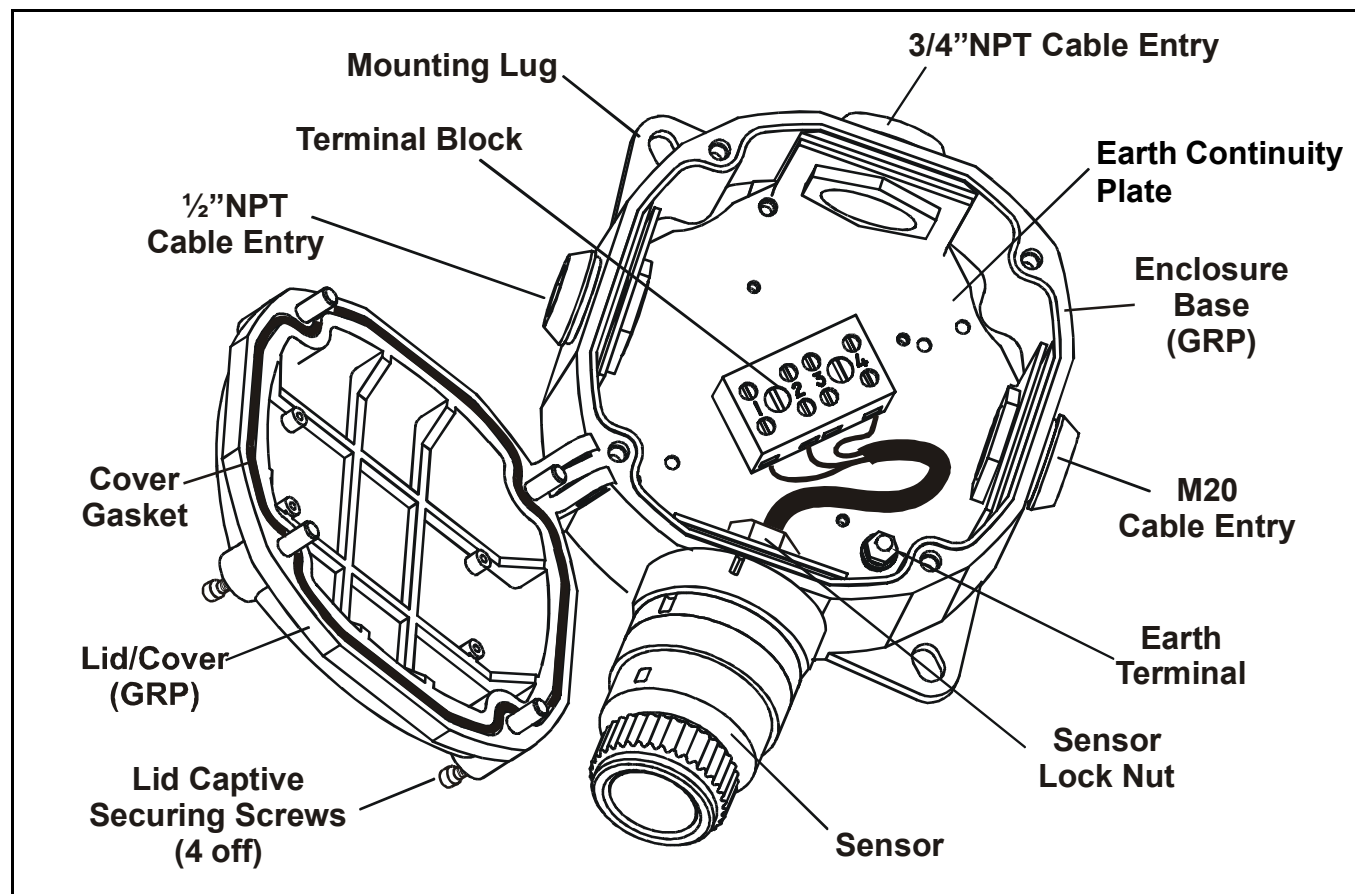

The detector is supplied with one of 3 types of sensor to monitor different gases present in ambient air:

- Flammable
- Toxic
- Oxygen

**Flammable detector (%LEL)** — this version measures flammable gas concentrations below the Lower Explosive Limit (LEL) of the target gas for which it is calibrated. It features a poison-resistant catalytic pellistor sensor device which forms part of a bridge measuring circuit.

**Toxic detector** — detects toxic gas, present in ambient air. Detectors measuring gas in parts per million (ppm) concentrations are available for detecting carbon monoxide (CO), hydrogen sulfide (H<sub>2</sub>S), hydrogen (H<sub>2</sub>), sulfur dioxide (SO<sub>2</sub>), nitrogen dioxide (NO<sub>2</sub>), and ammonia (NH<sub>3</sub>) gas. The Toxic and oxygen detectors feature a local amplifier for operation as part of a 4-20 mA circuit.

**Oxygen detector** — measures oxygen deficiency levels in air in percent by volume (%V/V) concentrations.

The detector gas type is shown on a label on the enclosure's lid.

All versions of the detector are designed for connection to a dedicated controller, e.g. Touchpoint<sup>1</sup> or Touchpoint<sup>4</sup> (contact your distributor for details).

The detector's construction allows unit dismantling for:

- gas sensors to be easily changed
- cabling to be routed and terminated
- commissioning/maintenance
- accessories to be fitted

The detector's screw-in sensor cannot be repaired but is replaced as a complete unit.

The certified enclosure acts as a junction box and is fitted with 3 cable entries and a 4-wire terminal block. The gas sensor is fitted to a tapped hole in the enclosure and is secured with a locknut.

The enclosure features a hinged lid that facilitates installation by a single technician when making electrical connections/changing the sensor.

The terminal block is used to connect sensor power/signals to an external controller. The three cable entry positions are fitted with approved seals. An earth continuity plate with earth terminal is fitted for added RFI protection.

All the detector types can be fitted with a range of accessories, e.g. filter, weather housing, collecting cone, and calibration gas flow adaptor.

Proper consideration must be made when locating the detector to ensure trouble free operation throughout its life.

## General

This document consists of the following chapters:

- Introduction
- Installation, see page 9
- Maintenance (including fault finding), see page 20
- Parts, see page 28
- Specification, see page 30
- Certification, see page 33



# Installation

## WARNINGS

***Sensepoint is designed for installation and use in Zone 1 or 2 hazardous areas in Europe. Installation must be in accordance with the recognized standards of the appropriate authority in the country concerned.***

***Before carrying out any work ensure local regulations and site procedures are followed. Appropriate standards must be followed to maintain the overall certification of the detector.***

***Access to the interior of the detector, when carrying out any work, must only be conducted by trained personnel. Switch off and isolate the power supply to the detector when access is required. Take any necessary precautions to prevent false alarms.***

***Never attempt to open a junction box/enclosure or replace/refit the sensor when flammable/toxic gas is present.***

***The detector must be earthed for electrical safety and to limit the effects of radio interference. An earth point is provided inside the unit. Ensure that all screens/armor are grounded at a single earth star point at the controller or detector - BUT NOT BOTH - to prevent false alarms due to earth loops.***

***Take care when handling sensors as they may contain corrosive solutions. Do not tamper or in any way dis-assemble the sensor. Do not expose to temperatures outside the recommended range. Do not expose sensor to organic solvents or flammable liquids.***

***At the end of their working life, sensors must be disposed of in an environmentally safe manner. Disposal should be according to local waste management requirements and environmental legislation. Alternatively, sensors may be securely packaged and returned to Honeywell Analytics clearly marked for environmental disposal. Electrochemical cells should NOT be incinerated as they may emit toxic fumes.***

***When replacing the gas detector's junction box ensure that the correct gas label is affixed to the replacement enclosure.***

---

***Cautions The detector's enclosure is suitable for installation within an explosive atmosphere as described in EN50014. Installation must be in accordance with EN60079 and current wiring regulations of the country where the enclosure is installed. The marking on the detector cover label must match the ambient temperature where the enclosure is installed. The detector enclosure is manufactured from glass-filled polyester (GFP) and fitted with stainless steel cover fixing screws, neoprene (or silicone) 'O' ring, and brass earth screws.***

**Contact with aggressive substances may affect the performance of these materials.**

**The detector is intended for use under normal industrial conditions and must not be installed in an area where extreme vibration may occur.**

**The enclosure has been tested to IP66 and with the cover fully tightened down and the use of suitable cable entry devices will maintain this protection under normal working conditions, however a minimum protection of IP64 must be achieved.**

---

This chapter provides the following information about installing **Sensepoint**:

- locating the detector, see **page 10**
- tools required, see **page 10**
- detector dimensions, see **page 11**
- mounting the detector, see **page 11**
- cabling, see **page 13**
- power, see **page 15**
- wiring, see **page 15**
- fitting accessories, see **page 19**

## Location

Honeywell can be installed indoors or outdoors.

The following sources give guidance when installing gas detectors:

- EN50073:1999 Guide for selection, installation, use and maintenance of apparatus for the detection and measurement of combustible gases or oxygen
- International codes of practice
- specifications defining minimum gas detection requirements for specific applications published by regulatory bodies

Mount the detector where gas is most likely to be present, noting the following points:

- for lighter-than-air gases mount the detector at a high level and preferably with the Collecting Cone accessory fitted
- mount at a low level for heavier-than-air gases
- if installed outdoors always consider possible damage caused by natural events, e.g. rain or flooding
- Ensure that a Weather Cover is fitted.
- ensure ease of access to the unit for commissioning and maintenance
- consider how escaping gas may behave due to natural or forced air currents
- check any associated process line conditions — gases may be normally heavier than air, but if released from a process that is at an elevated temperature and/or under pressure, the gas may rise rather than fall
- Document the agreed location of detectors

Follow the advice of:

- experts having specialist knowledge of gas dispersion
- experts having knowledge of the process plant system and equipment involved
- safety and engineering personnel

## Tools

The following tools are required for installation:

- Hex Key, 4 mm (0.16 in.) A/F — for cover fixing screws.
- 7 mm (0.28 in.) drill — for mounting holes

*Note* Fixing screws/bolts are not supplied.

## Dimensions

The subsequent diagrams show dimensions for **Sensepoint**.

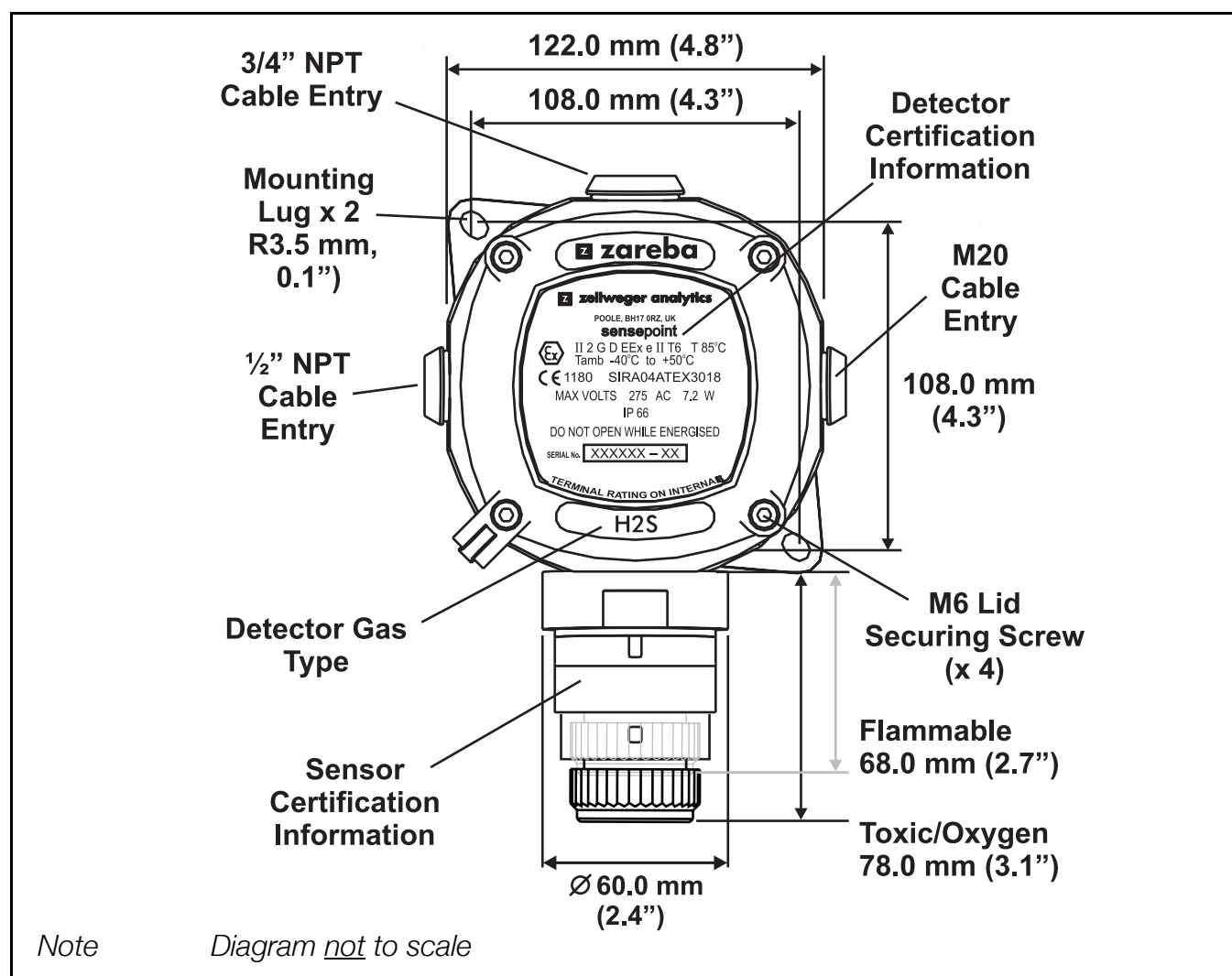

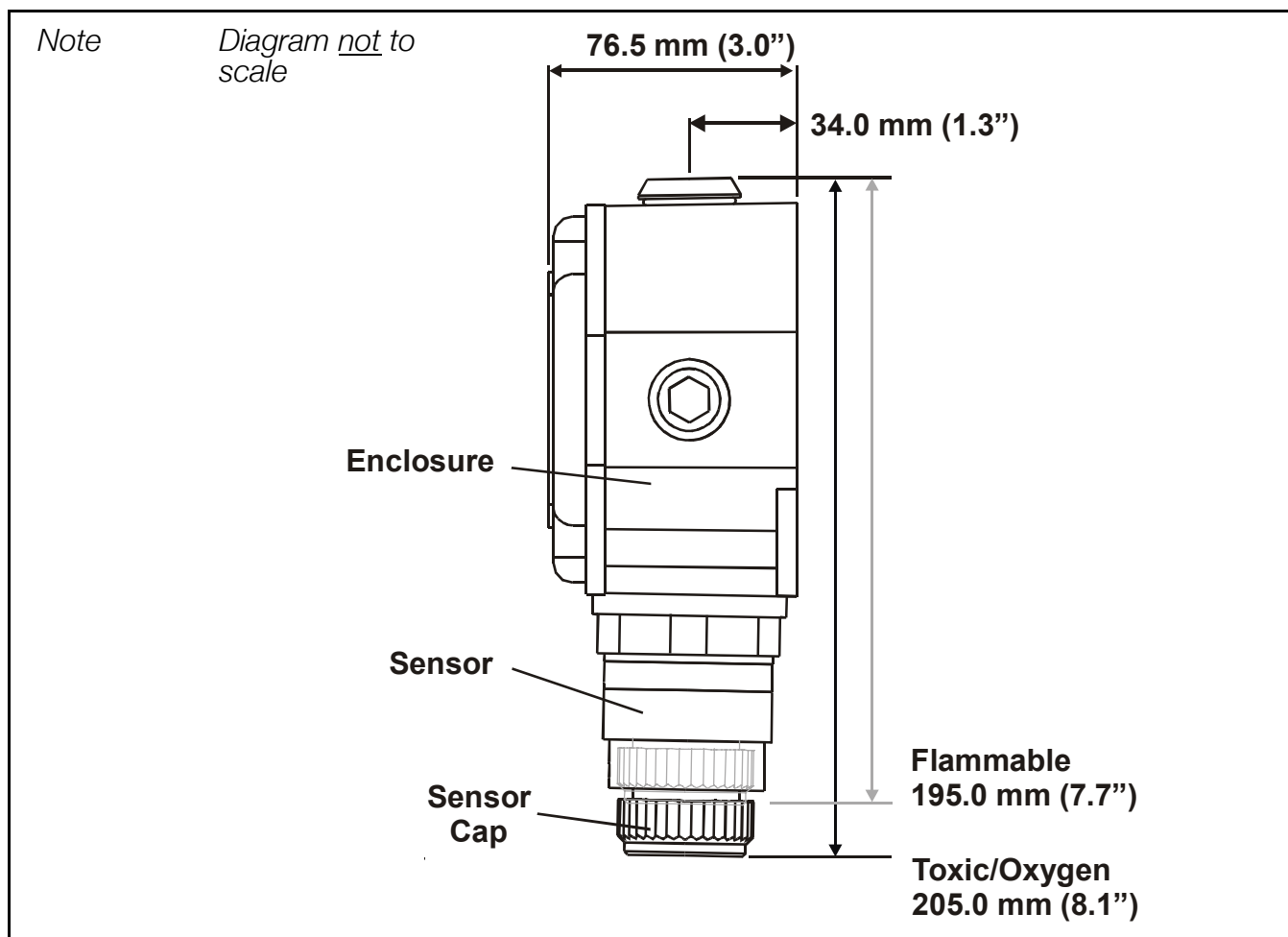

## Mounting

---

**Caution** *The enclosure must be fixed in position using the external mounting lugs and not mounted using any type of cable entry device.*

---

**Sensepoint** should be fitted to a flat firm surface suitable for the unit's size and weight, e.g. a wall, as follows:

**1 Drill two mounting holes in the surface.**

*The surface should be flat and firm. For sizes, position, etc. see the previous dimension drawing.*

**2 Mount the detector using its two mounting lugs.**

*Use M6 screws/bolts. Mount the unit with the gas sensor pointing downwards to ensure that dust/water will not collect on the sensor, and to stop gas entering the detector.*

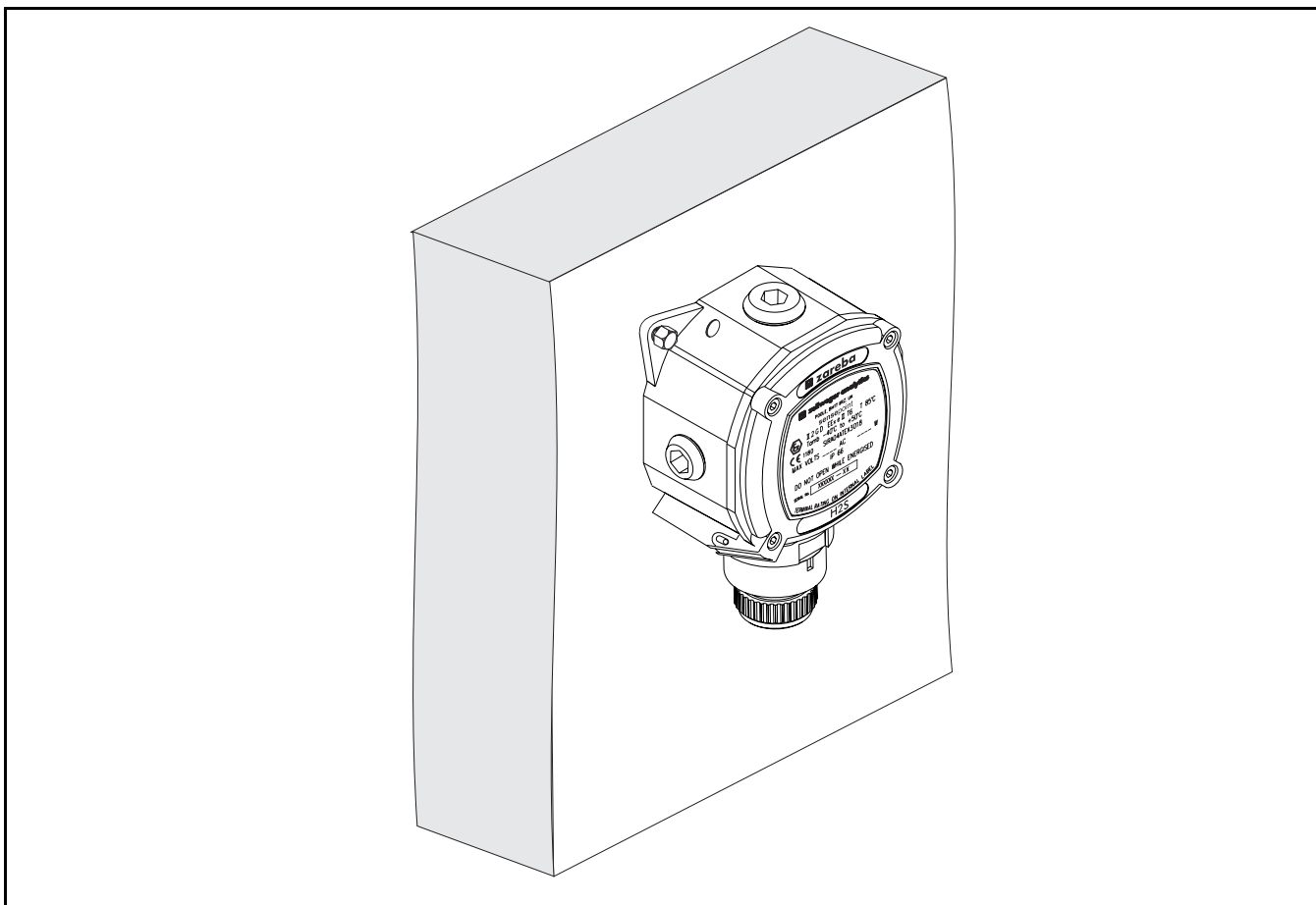

## Electrical

---

**Caution** *Cabling and wiring must be in accordance with the recognized standards of the appropriate authority in the host country and meet the electrical requirements of the detector and controller.*

---

## Cabling

Cabling may be SWA cable or conduit run. Wire size 1.0 to 2.5 mm<sup>2</sup> (17 to 14 AWG) max., with suitable M20 explosion-proof gland, or 1/2 in. NPT, or 3/4 in. NPT steel conduit. Use any of the 3 cable/conduit entries.

The following diagrams show how to earth bond Steel Wired Armored (SWA) cable at enclosures. The same principles apply to conduit installations. These bonding techniques provide good RFI/EMC performance. Ground/earth loops must be avoided to prevent false alarms.

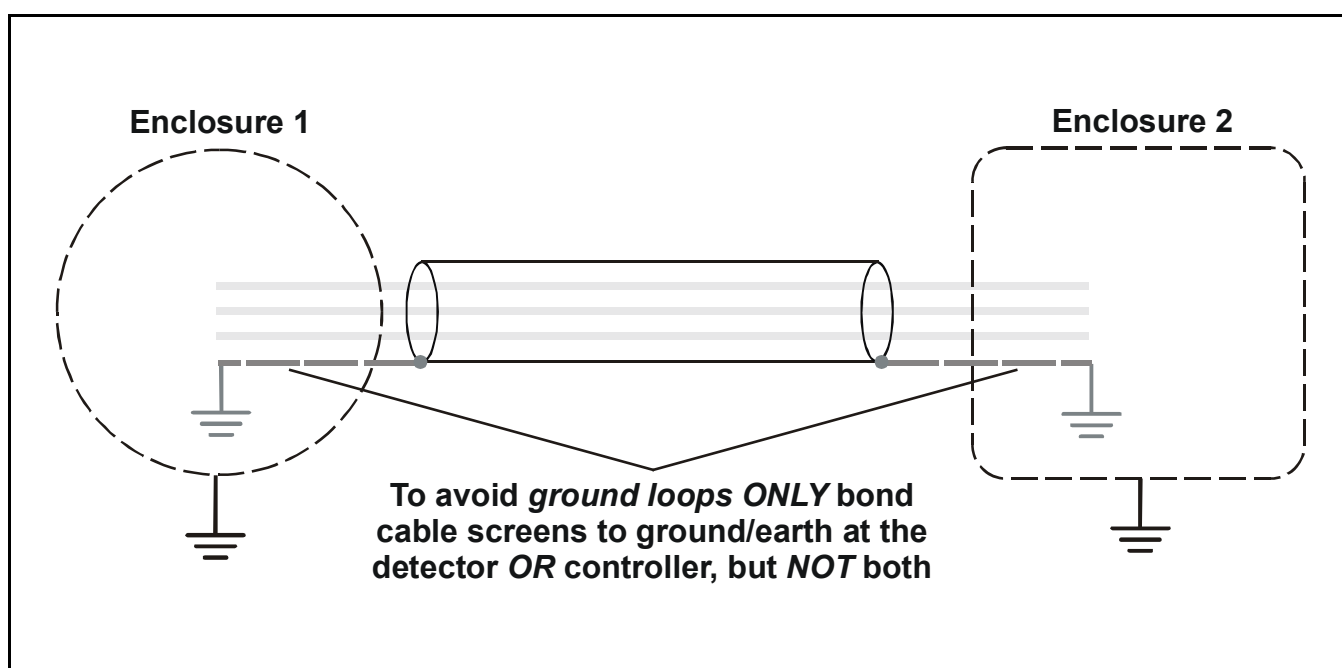
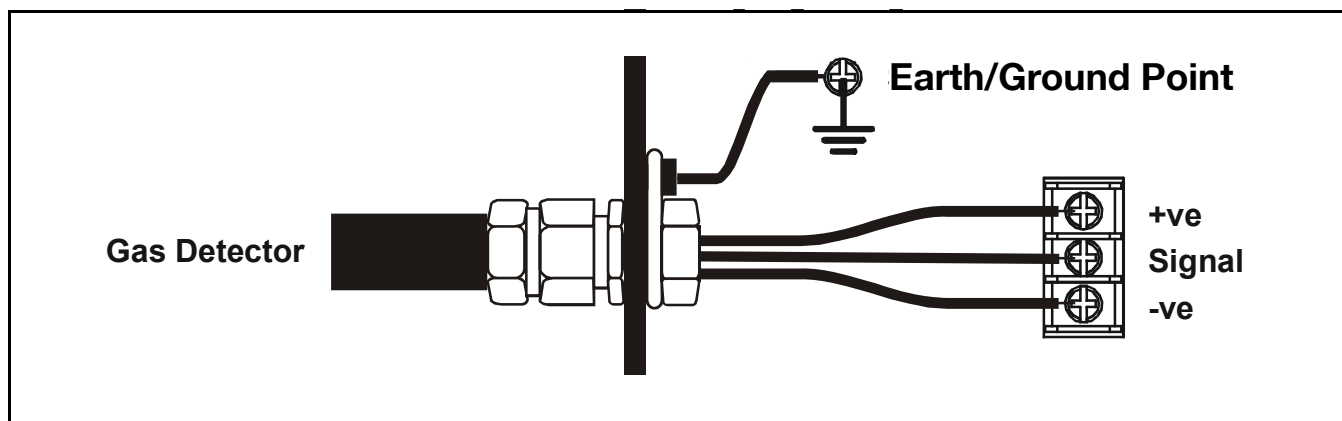

To install cabling use the following procedure:

**1 Open the lid of the enclosure.**

*Unscrew the four M4 captive securing screws, using a 4 mm (0.16 in.) A/F hex key wrench. The lid is attached to the base by a retaining hinge. Lift the lid vertically away from the enclosure base and then tilt it away from the base.*

**2 Fit the field cabling to the enclosure.**

*Use either of the following:*

*Conduit - Ensure that a conduit sealing fitting is placed within 18 in. of the enclosure on all conduit runs.*

*Cable - using any suitable certified cable entry device.*

*Use armored multi-core cable, 2-wire plus screen for toxic/oxygen detector, 3-wire for flammable detector. Cable entry devices must be selected in accordance with the marking on the certification label on the cover of the enclosure.*

*Note All unused cable/conduit entries must be sealed with the supplied certified sealing plug.*

## Power

The toxic detector requires a power supply of 16-30 Vdc (at up to 30 mA). Ensure that a minimum supply of 16 Vdc is measured at the detector, taking into account the voltage drop due to cable resistance. For example, the nominal DC supply at the control panel has a guaranteed minimum supply of 18 Vdc. The maximum cable voltage drop allowed is therefore 2 Vdc.

The flammable detector requires 2.9 Vdc to 3.5 Vdc bridge (at 200 mA).

Refer to the control panel manual for allowable maximum cable lengths.

## Wiring

---

**Caution** *An earth point is provided inside the controller. Ensure that all detector screens/armor are grounded at a single earth star point at the detector or controller – BUT NOT BOTH – to prevent false alarms due to earth loops.*

---

All connections are made via the terminal block inside the detector housing.

### 1 Open the enclosure lid.

*Unscrew the four M4 captive securing hex. screws, using a 4 mm (0.16 in.) A/F hex key wrench. The lid is attached to the base by a retaining hinge. Lift the lid vertically away from the enclosure base and then tilt it away from the base.*

### 2 Terminate the field wiring.

---

**Cautions** *All conductors must be fully tightened down within the terminals. Conductor tightening screws must be below the surface of the terminal and it is important that the correct sized screwdriver is used. An oversized screwdriver will break the insulation around the terminal.*

*The enclosure is fitted with an earth continuity plate and internal and external earth studs. A suitable ring-type terminal lug must always be used to secure the earth conductor.*

---

See the following diagrams for connection details.

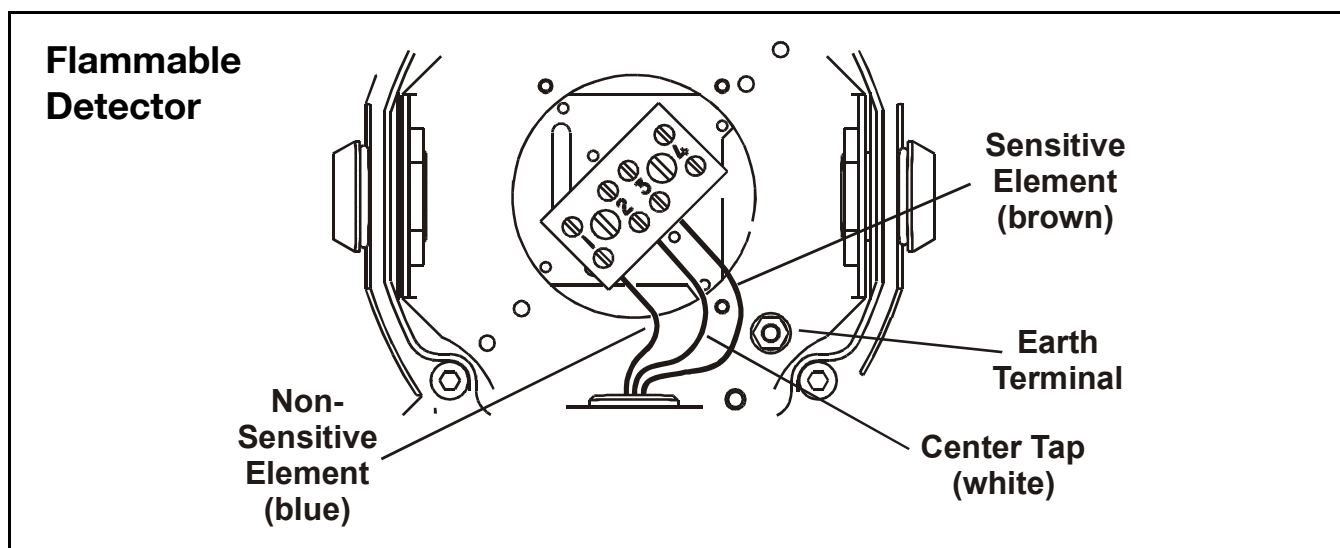
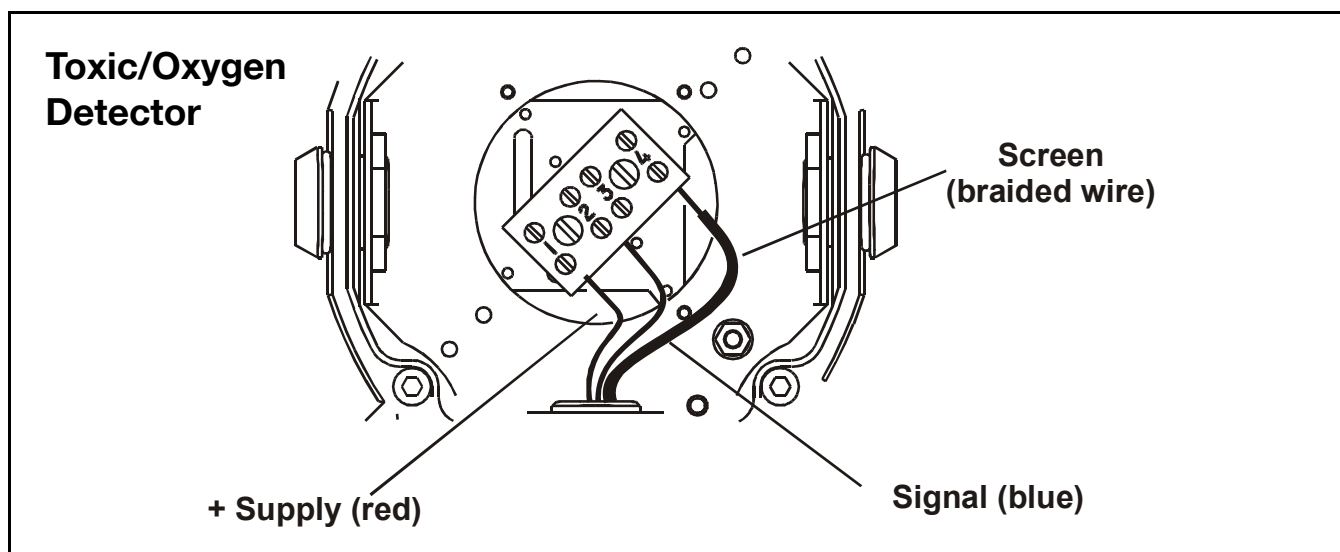

3 Close the lid of the enclosure and secure it.

---

**Cautions** *Ensure there is no moisture inside the enclosure before closing the lid.*

*Ensure the seal, between the body and the cover, is correctly located and is secure.*

*Ensure the cover is securely clamped to the body of the enclosure.*

*Use only the captive fixing screws supplied, replacement with alternative screws will invalidate certification.*

---

*Fully tighten the four M4 captive securing hex screws.*

4 Carry out one of the following two procedures.



There is a procedure for all sensors except oxygen, and one for oxygen only. The procedure activates the sensor before putting the detector into service.

### All Detectors EXCEPT Oxygen

- a. Remove the sensor cap.

Unscrew the cap in a counter-clockwise direction. Refer to the following diagram.

- b. Remove the protective disc from inside the sensor cap.

Discard the disc.

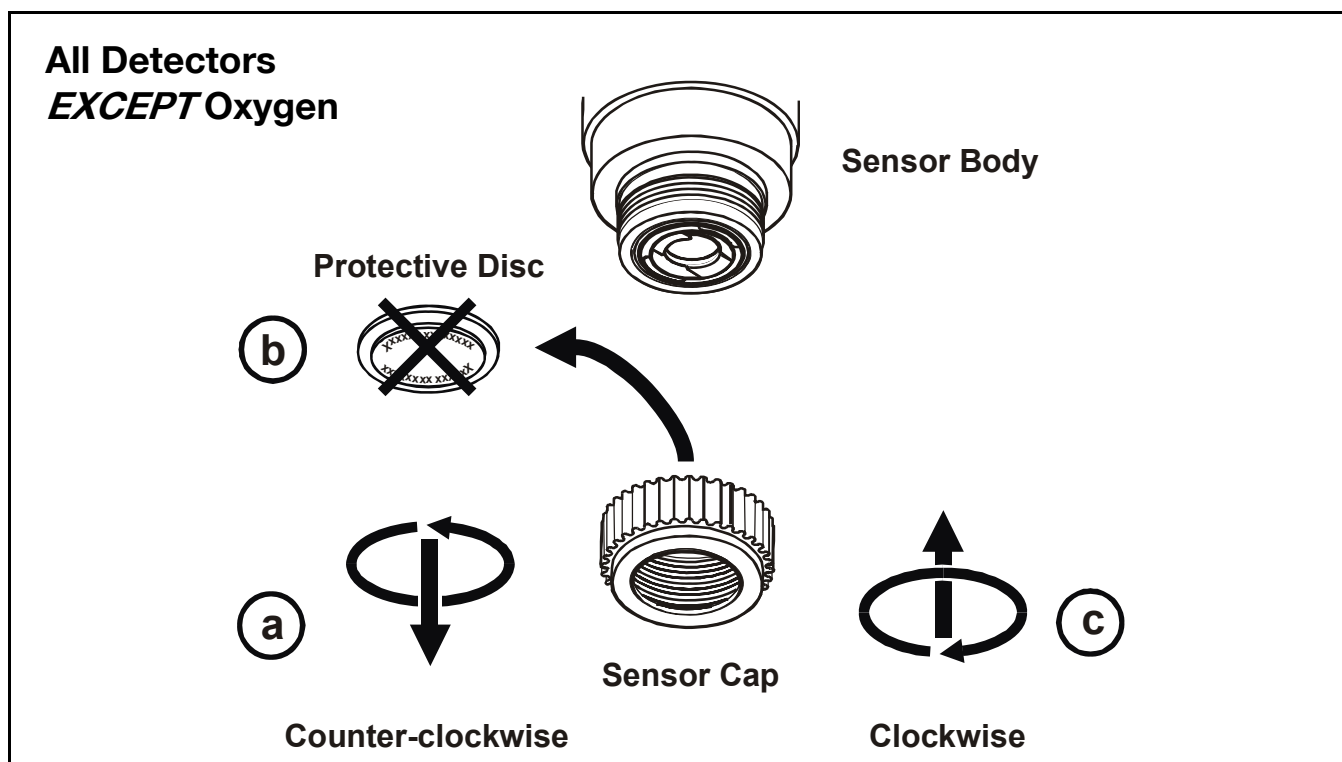

- c. Refit the sensor cap.

Screw the cap in a clockwise direction. If required fit an accessory. Refer to the instructions supplied with the item except for fitting outer filters, see **page 19**.

### Oxygen Detectors ONLY

- a. Remove the sensor cap.

Unscrew the cap in a counter-clockwise direction. Refer to the following diagram.

- b. Remove the protective disc from inside the sensor cap.

Discard the disc.

- c. Remove the cell's protective plug.

The plug is stuck to the face of the sensor's cell using a light adhesive. Peel the plug off and discard it.

- d. Remove the supplied RFI screen and inner filter from the packing bag.
- e. Fit the two components to the sensor.

*Fit them in the order shown in the diagram. Insert both of them evenly. Push the inner filter into the neck of the sensor body until its locating tags click into place.*

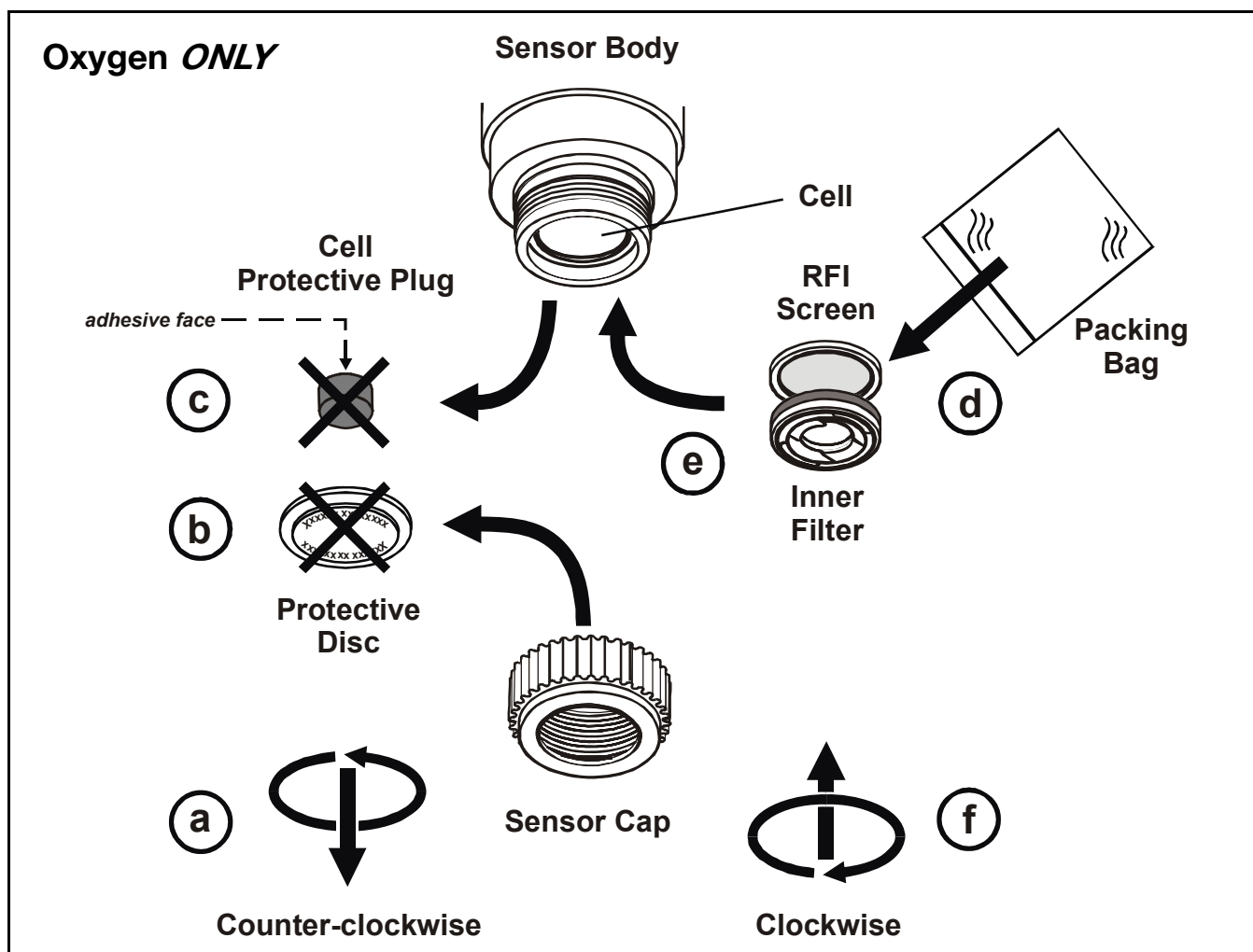

- f. Refit the sensor cap.

*Screw the cap in a clockwise direction. If required fit an accessory. Refer to the instructions supplied with the item except for fitting outer filters, see **page 19**.*

- **Power the unit and check for correct operation of the detector.**

*Check the gas reading at the controller. Refer to the controller's user documentation.*

## Accessories

The following accessories are available for use with the detector:

- weather housing
- flow housing
- collecting cone
- filters

Also see page 28.

To fit all the accessories refer to the instructions supplied with the item, except for fitting outer filters, see the following procedure.

### Fitting an Outer Filter

This procedure applies to all types of **Sensepoint** gas detector. Refer to the following diagram.

#### 1 Remove the sensor cap (or accessory).

*Unscrew the cap/accessory in a counter-clockwise direction.*

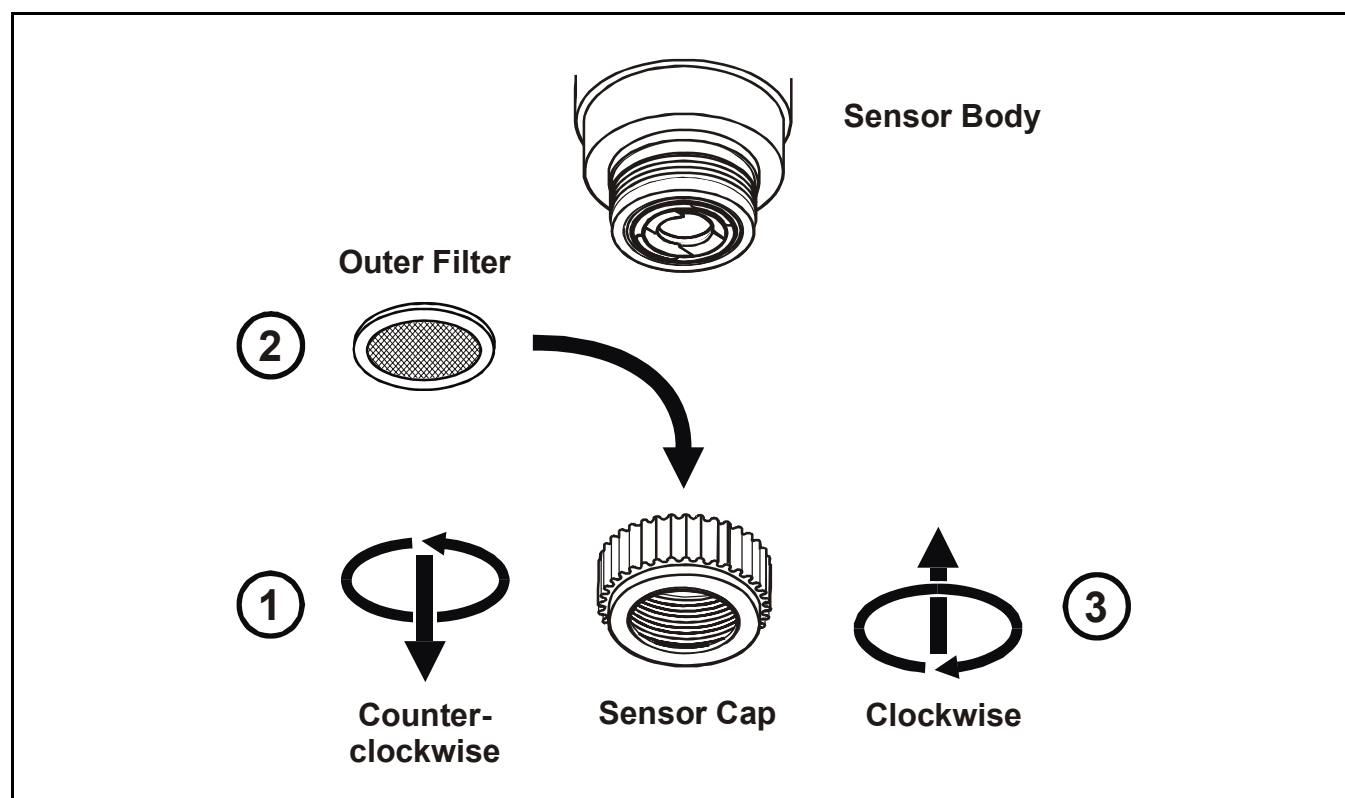

#### 2 Fit the outer filter.

*The filter fits inside the Sensor Cap.*

#### 3 Refit the sensor cap (or accessory).

*Screw the cap/accessory firmly in a clockwise direction.*

# Maintenance

## WARNINGS

***Sensepoint is designed for installation and use in Zone 1 or 2 hazardous areas in Europe. Installation must be in accordance with the recognized standards of the appropriate authority in the country concerned.***

***Before carrying out any work ensure local regulations and site procedures are followed. Appropriate standards must be followed to maintain the overall certification of the detector.***

***Access to the interior of the detector, when carrying out any work, must only be conducted by trained personnel. Switch off and isolate the power supply to the detector when access is required. Take any necessary precautions to prevent false alarms.***

***Never attempt to open a junction box/enclosure or replace/refit the sensor when flammable/toxic gas is present.***

***The detector must be earthed for electrical safety and to limit the effects of radio interference. An earth point is provided inside the unit. Ensure that all screens/armor are grounded at a single earth star point at the controller or detector - BUT NOT BOTH - to prevent false alarms due to earth loops.***

***Take care when handling sensors as they may contain corrosive solutions. Do not tamper or in any way dis-assemble the sensor. Do not expose to temperatures outside the recommended range. Do not expose sensor to organic solvents or flammable liquids.***

***At the end of their working life, sensors must be disposed of in an environmentally safe manner. Disposal should be according to local waste management requirements and environmental legislation. Alternatively, sensors may be securely packaged and returned to Honeywell Analytics clearly marked for environmental disposal. Electrochemical cells should NOT be incinerated as they may emit toxic fumes.***

***When replacing the gas detector's junction box ensure that the correct gas label is affixed to the replacement enclosure.***

This chapter describes the following:

- expected operational life of the sensor
- gas sensor replacement, see **page 22**
- replacing a junction box, see **page 24**
- changing the outer filter, see **page 26**
- troubleshooting, see **page 26**

## **Operational Life**

The pellistors used in the flammable gas sensor can suffer from a loss of sensitivity when in the presence of poisons or inhibitors, e.g. silicones, sulfides, chlorine, lead or halogenated hydrocarbons.

The pellistors are poison resistant to maximize the operational life of the flammable sensor.

A typical operating life, subject to the presence of poisons/inhibitors is in excess of 3 years.

The operational life of toxic sensors depends on the application, frequency and amount of gas exposure.

Under normal conditions both the carbon monoxide and hydrogen sulfide sensors have an expected operating life of greater than 24 months.

The oxygen, hydrogen, chlorine, sulfur dioxide, nitrogen dioxide, and ammonia sensors have an expected operating life of greater than 12 months.

When the sensor has passed its useful operating life replace it by following the subsequent procedure.

## Sensor Replacement

---

**Caution** *ONLY* replace a sensor with another of the same type.

---

The gas detector is fitted with a replaceable sensor which has no user-serviceable parts. At the end of the sensor's life replace it using the following procedure:

To change a sensor carry out the following procedure:

- 1 Isolate all associated power supplies and ensure that they remain OFF during the this procedure.
- 2 Open the enclosure lid.

*Unscrew the four M4 captive securing hex. screws, using a 4 mm (0.16 in.) A/F hex key wrench. The lid is attached to the base by a retaining hinge. Lift the lid vertically away from the enclosure base and then tilt it away from the base.*

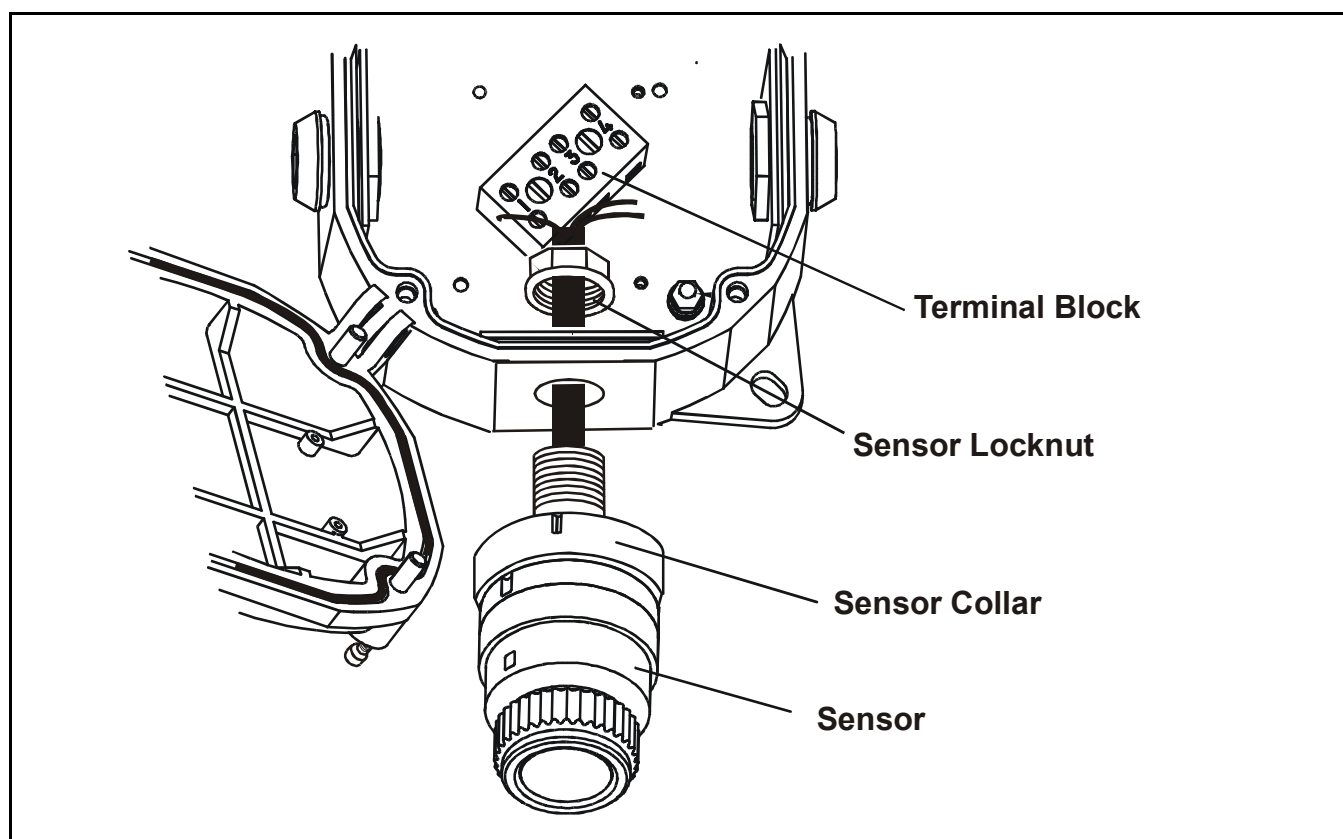

- 3 Disconnect the sensor wiring at the terminal block.  
*Record the position of the wiring.*
- 4 Unscrew and remove the sensor's M20 locknut.
- 5 Remove the sensor from the enclosure.

*Grip the sensor collar firmly where it meets the enclosure and unscrew the sensor in a counter-clockwise direction. Refer to the warning about sensor handling and disposal at the start of this chapter.*

- 6 Fit the new sensor by reversing the removal procedure.

*Check that the replacement sensor is the correct type. Screw the sensor firmly in a clockwise direction into the enclosure base until tight.*

- 7 Refit the M20 locknut.

---

**Caution** *The locknut must be fitted to maintain certification.*

---

- 8 Reconnect the sensor wiring at the terminal block.

---

**Cautions** *All conductors must be fully tightened down within the terminals. Conductor tightening screws must be below the surface of the terminal and it is important that the correct sized screwdriver is used. An oversized screwdriver will break the insulation around the terminal.*  
*The enclosure is fitted with an earth continuity plate and internal and external earth studs. A suitable ring-type terminal lug must always be used to secure the earth conductor.*

---

- 9 Close the enclosure lid and secure it.

---

**Cautions** *Ensure there is no moisture inside the enclosure before closing the lid.*  
*Ensure the seal, between the body and the cover, is correctly located and is secure.*  
*Ensure the cover is securely clamped to the body of the enclosure.*  
*Use only the captive fixing screws supplied, replacement with alternative screws will invalidate certification.*

---

*Fully tighten the four M4 captive securing hex screws.*

- 10 Dispose of the removed sensor.

*Refer to the warning about sensor handling and disposal at the start of this chapter.*

- 11 Power-up the detector and check its operation.

*Wait until the detector has completed its warm-up period, see page 30. The controller may need to be calibrated for the new detector. See the controller's manual for more information.*

## Junction Box Replacement

This section tells how to:

- remove the sensor from the enclosure
- replace the existing junction box with a replacement
- refit the original sensor to the new box

Carry out the following procedure, referring to the previous diagram:

- 1 Isolate all associated power supplies and ensure that they remain OFF during the this procedure.
- 2 Open the enclosure lid.  
*Unscrew the four M4 captive securing hex. screws, using a 4 mm (0.16 in.) A/F hex key wrench. The lid is attached to the base by a retaining hinge. Lift the lid vertically away from the enclosure base and then tilt it away from the base.*
- 3 Disconnect the sensor wiring at the terminal block.  
*Record the position of the wiring.*
- 4 Unscrew and remove the sensor's M20 locknut.
- 5 Remove the sensor from the enclosure.  
*Grip the sensor collar firmly where it meets the enclosure and unscrew the sensor in a counter-clockwise direction. Refer to the warning about sensor handling and disposal at the start of this chapter.*
- 6 Put the sensor and M20 locknut to one side for re-fitting later.
- 7 Disconnect the controller wiring at the terminal block.  
*Record the position of the wiring.*
- 8 Remove the controller cable and gland from the box
- 9 Remove the junction box from its mounting.  
*The box is attached by two mounting lugs and M6 screws/bolts. Record the type of gas label affixed to the front of the enclosure. Discard the box.*
- 10 Fit the new junction box.  
*Part number: SPSTJB. Use M6 screws/bolts. Also check the installation instructions, see page 11.*
- 11 Fit a new gas label to the new box.  
*The new junction box is supplied with gas labels for all nine types of gas detector. Read the warning about the gas label at the start of this chapter. Ensure the correct one is fitted.*
- 12 Open the new enclosure lid.  
*Unscrew the four M4 captive securing hex. screws, using a 4 mm (0.16 in.) A/F hex key wrench. The lid is attached to the base by a retaining hinge. Lift the lid vertically away from the enclosure base and then tilt it away from the base.*



- 13 Refit the original sensor to the new box.  
*Screw the sensor firmly in a clockwise direction into the enclosure base until tight.*
- 14 Refit the M20 locknut.

---

**Caution** *The locknut must be fitted to maintain certification.*

---

- 15 Reconnect the sensor wiring at the terminal block.

---

**Cautions** *All conductors must be fully tightened down within the terminals. Conductor tightening screws must be below the surface of the terminal and it is important that the correct sized screwdriver is used. An oversized screwdriver will break the insulation around the terminal.*  
*The enclosure is fitted with an earth continuity plate and internal and external earth studs. A suitable ring-type terminal lug must always be used to secure the earth conductor.*

---

*Refer to your written record for the position of the wiring, or see page 15.*

- 16 Refit the controller cable to the new box.  
*Fit a new cable gland.*
- 17 Reconnect the controller wiring at the terminal block.  
*Refer to your written record for the position of the wiring, or see page 15.*
- 18 Close the lid of the enclosure and secure it.

---

**Cautions** *Ensure there is no moisture inside the enclosure before closing the lid.*  
*Ensure the seal, between the body and the cover, is correctly located and is secure.*  
*Ensure the cover is securely clamped to the body of the enclosure. Use only the captive fixing screws supplied, replacement with alternative screws will invalidate certification.*

---

*Fully tighten the four M4 captive securing hex screws.*

- 19 Power-up the detector and check its operation.  
*The controller may need to be calibrated for the new detector. See the controller's manual for more information.*

## Changing the Outer Filter

This procedure applies to all types of **Sensepoint** gas detector. Refer to the following diagram.

- 1 Remove the sensor cap (or accessory).  
*Unscrew the cap/accessory in a counter-clockwise direction.*
- 2 Remove the outer filter.  
*Discard the old filter.*
- 3 Fit the new outer filter.
- 4 Refit the sensor cap (or accessory).  
*Screw the cap/accessory firmly in a clockwise direction.*

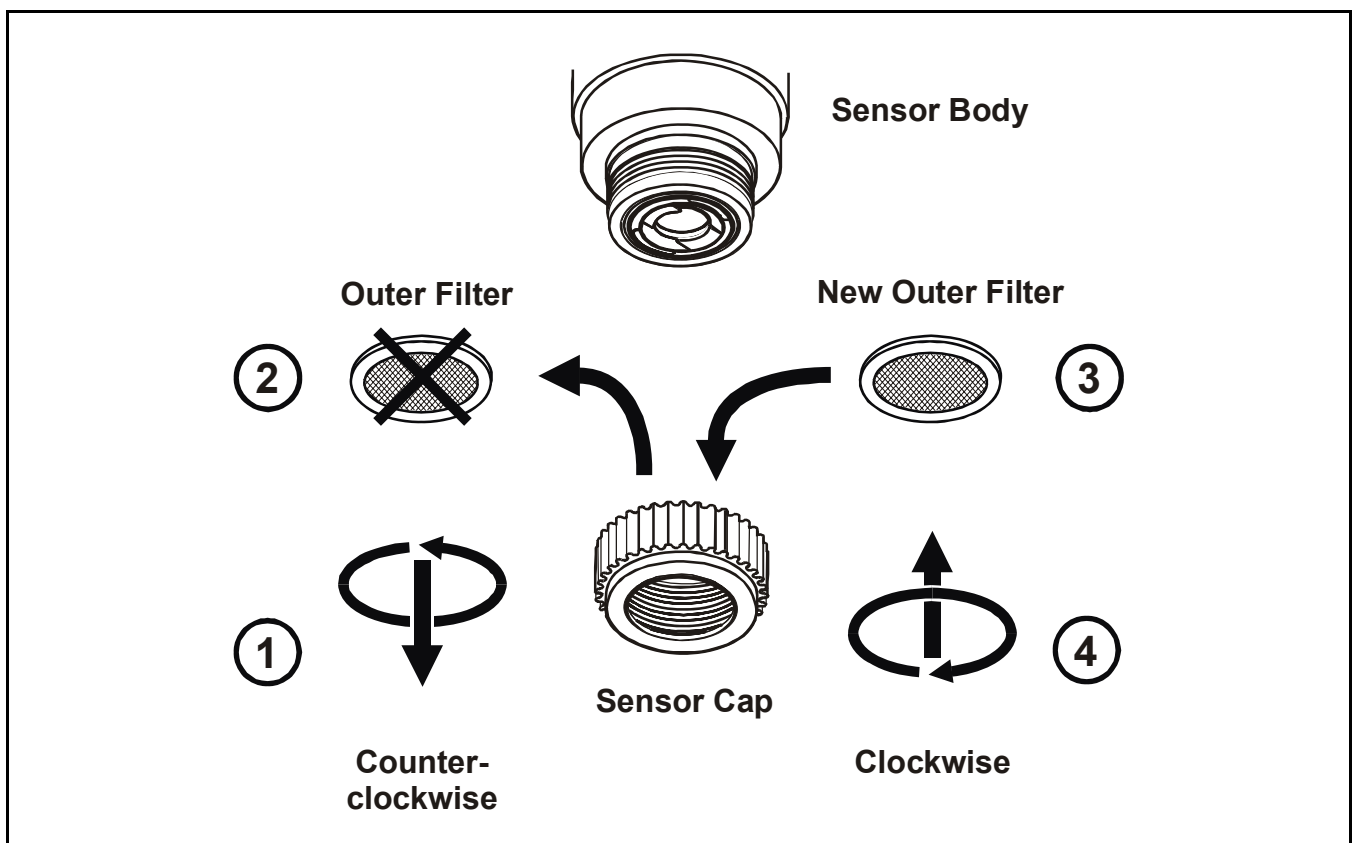

## Fault Finding

The following table provide fault finding information. Readings are seen at the controller.

Symptom	Action	Reference
False/inconsistent reading(s)	Check: 1. Detector wiring/grounding 2. Sensor filter condition — replace if dirty 3. Sensor expiration date	See <b>page 26</b>
Reading non-zero all the time	Check to ensure that there is no target gas in the atmosphere. Background or other volatile organic gases, e.g. solvents, can interfere with the operation of the sensor.	
Reading non-zero with no gas present	Adjust the zero setting at the controller.	Controller's user document
Reading low when gas applied	Adjust the span setting at the controller.	Controller's user document
	For oxygen versions, check that the protective plug has been removed from the cell and the RFI screen and filter have been fitted.	See page 17
Reading high when gas applied	Adjust the span setting at the controller.	Controller's user document
Reading zero when gas applied	Check the sensor Protective Disc, fitted to the cap when the sensor is supplied, has been removed.	See page 17
	For oxygen versions, also check that the protective plug has been removed from the sensor cell and the RFI screen and filter have been fitted.	See page 17
	Check that the filters are not blocked.	
	Replace the sensor if failure is suspected.	See <b>page 22</b>
Cannot adjust span or zero	No adjustments can be made at the detector, only at the controller.	Controller's user document
Calibration fails at controller	Replace detector	See <b>page 22</b>

Contact Honeywell Analytics if the problem isn't resolved, see back page for contact information.

# Parts

This chapter lists part numbers for spare items and accessories.

## Sensors

---

**Caution** *ONLY replace a sensor with another of the same type.*

---

Gas Type	Range	Part No.
<b>Flammable</b>		
	0-100% LEL Methane	SPSTAXF1SS
<b>Toxic</b>		
<b>Ammonia</b>	0-50 ppm	SPSTAXA1SS
	0-1,000 ppm	SPSTAXA2SS
<b>Carbon monoxide</b>	0-200 ppm	SPSTAXC1SS
	0-500 ppm	SPSTAXC2SS
<b>Chlorine</b>	0-5 ppm	SPSTAXL1SS
	0-15 ppm	SPSTAXL2SS
<b>Hydrogen</b>	0-1,000 ppm	SPSTAXG1SS
	0-10,000 ppm	SPSTAXG2SS
<b>Hydrogen sulfide</b>	0-50 ppm	SPSTAXH1SS
	0-20 ppm	SPSTAXH2SS
	0-100 ppm	SPSTAXH3SS
<b>Nitrogen dioxide</b>	0-10 ppm	SPSTAXN1SS
<b>Sulfur dioxide</b>	0-15 ppm	SPSTAXS1SS
	0-50 ppm	SPSTAXS2SS
<b>Oxygen</b>	25% VOL	SPSTAXO1SS

## Other Parts

Description	Part No.
ATEX approved, universal Junction box, complete with labels	SPSTJB

## Accessories

Description	For	Part No.
Weather housing – includes remote gassing nozzle	Flammable Sensor	02000-A-1635
	Toxic/oxygen Sensor	02000-A-1640
Collecting cone	Flammable Sensor	02000-A-1642
Calibration Gas Flow housing	Both detector types	02000-A-1645
Right angle mounting bracket (for ceiling mount)	Both detector types	02000-A-0160

# Specifications

## General

<b>Use</b>	Fixed point gas detector for the protection of personnel and plant from flammable, toxic or oxygen gas hazards.
------------	---

## Detectable Gases

Gas Type/Gas	Ranges	Warm-up (min)	Operating Temperature*	
			Minimum	Maximum.
<b>Flammable</b>	0-100% LEL Methane	<10	-40°C (-40°F)	+50°C (122°F)
<b>Toxic</b>				
<b>Ammonia</b>	0-50 ppm	<3	-20°C (-4°F)	+40°C (104°F)
	0-1,000 ppm			
<b>Carbon monoxide</b>	0-200 ppm		-20°C (-4°F)	+50°C (122°F)
	0-500 ppm			
<b>Hydrogen</b>	0-1,000 ppm		-5°C (23°F)	+40°C (104°F)
	0-10,000 ppm			
<b>Hydrogen sulfide</b>	0-50 ppm		-25°C (-13°F)	+50°C (122°F)
	0-20 ppm			
	0-100 ppm			
<b>Chlorine</b>	0-5 ppm		<5	-20°C (-4°F)
	0-15 ppm			
<b>Nitrogen dioxide</b>	0-10 ppm	<60	-15°C (5°F)	+40°C (104°F)
<b>Sulfur dioxide</b>	0-15 ppm	<3	-15°C (5°F)	+40°C (104°F)
	0-50 ppm			
<b>Oxygen</b>	0-25% Vol	<5	-15°C (5°F)	+40°C (104°F)

\* Maximum certified temperature

## Electrical

Flammable	Toxic/Oxygen	Enclosure
3-wire mV bridge 2.9-3.5 Vdc, 0.7 W (max.), constant current operation at 200 mA	2-wire loop powered 4-20 mA (plus screen), 16-30 Vdc, 0.9 W	Earth continuity plate BK4 4-wire Terminal block 4-wire, 0.5 to 2.5 mm <sup>2</sup> (20 -14 AWG). Cable entries: 1 x M20, 1 x ½ in. NPT, 1 x ¾ in. NPT

## Physical

	Flammable Sensor	Toxic/Oxygen Sensor	Enclosure
<b>Material</b>	Polyphenylene Sulfide (PPS)	Polyphenylene Sulfide (PPS)	Fire retardant Glass Filled Polyester (GFP)
<b>Weight</b>	190 g	185 g 205 g oxygen	600 g

## Certification

Flammable	Toxic/Oxygen	Enclosure
Ex II 2 G D EEx d IIC T6 T85°C T <sub>amb</sub> = -55°C to +55°C BAS98ATEX2156X SIRA03ATEX1116X - Performance	Ex II 2 G D EEx d ia IIC T4 T135°C T <sub>amb</sub> = -55°C to +65°C BAS90ATEX2157X	Ex II 2 G D EEx e II T6 T85°C T <sub>amb</sub> = -40°C to +50°C SIRA04ATEX3018

Also see page 33.

## Applicable Standards

	Flammable	Toxic	EMC
<b>Standard</b>	EN50270	EN445544 (H <sub>2</sub> S only)	EN50270

## Environmental

<b>IP rating</b>	IP65, IP66 with Weather housing in accordance with EN60529:1992
<b>Operating temperature</b>	Dependent upon gas type and certification
<b>Operating humidity range</b>	Continuous: 20-90% RH (non-condensing) Intermittent: 10-99% RH (non-condensing)
<b>Operating pressure</b>	90-110 kPa
<b>Storage conditions</b>	Instrument -40°C to +50°C (-40°F to +122°F).



Thank you for reading this data sheet.

For pricing or for further information, please contact us at our UK Office, using the details below.



**UK Office**

**Keison Products,**

**P.O. Box 2124, Chelmsford, Essex, CM1 3UP, England.**

**Tel: +44 (0)330 088 0560**

**Fax: +44 (0)1245 808399**

**Email: [sales@keison.co.uk](mailto:sales@keison.co.uk)**

Please note - Product designs and specifications are subject to change without notice. The user is responsible for determining the suitability of this product.