

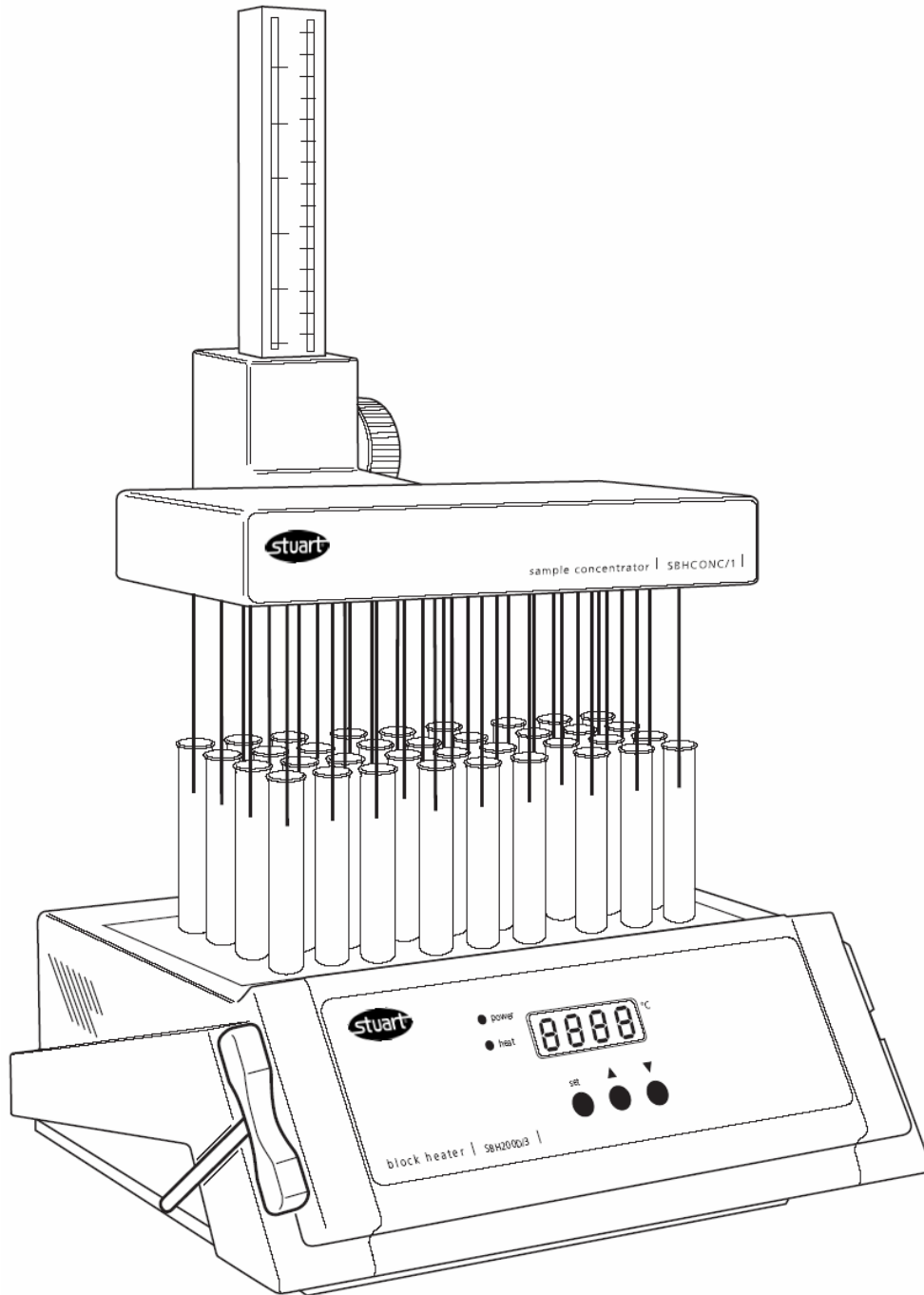

Sample Concentrator

SBH CONC/1
Instructions for use



Thank you for purchasing this piece of Barloworld Scientific equipment. To get the best performance from the equipment, and for your own safety, please read these instructions carefully before use.

This equipment is designed to operate under the following conditions:-

- ❖ For indoor use only
- ❖ Use in a well ventilated area
- ❖ Ambient temperature range +5°C to +40°C
- ❖ Altitude to 2000m
- ❖ Relative humidity not exceeding 80%
- ❖ Pollution degree 2 IEC664

If the equipment is not used in the manner described in this manual the protection provided by the equipment may be impaired.

General Description

The Stuart sample concentrator, when used in conjunction with a Stuart block heater accelerates the evaporation process of samples of solution for analysis. With the heat generated from the block heater and the steady flow of gas above the surface of the sample, to carry away evaporated products, the rate of sample concentration is significantly increased. The Stuart sample concentrator is only compatible with the three block, SBH130D/3 or SBH200D/3, models of Stuart block heater.

The sample concentrator is made up of gas chamber sited on a height adjustable stand, to allow accurate positioning above the samples. Hyperdermic needles penetrate a membrane within the gas chamber and carry the gas from the chamber into the sample test tubes.

Safety Advice Before Use

- ❖ Care should be taken when using hot apparatus, high temperatures can cause serious burns and ignite combustible material
- ❖ Never move or carry the unit when in use
- ❖ Always use a gas regulator to control the flow of gas to the sample concentrator, do not exceed 2 psi at the intake valve
- ❖ Do not put hot objects near combustible objects
- ❖ Do not place liquid directly into your block heater

Installation

To help reduce packaging material the sample concentrator is delivered in three parts; the base board, the column and carriage, and the gas chamber. Follow the instructions and diagram below to reassemble:

1. Unscrew the fastening knob at the rear of the base board, locate the column on the two pins in the support bracket. Tighten the fastening knob to secure the column in place.
2. Insert the locating pin at the rear of the gas chamber into gas chamber location hole on the carriage, taking care to line up the positioning pin, tighten the locking nut at the side of the carriage to secure the gas chambers position.

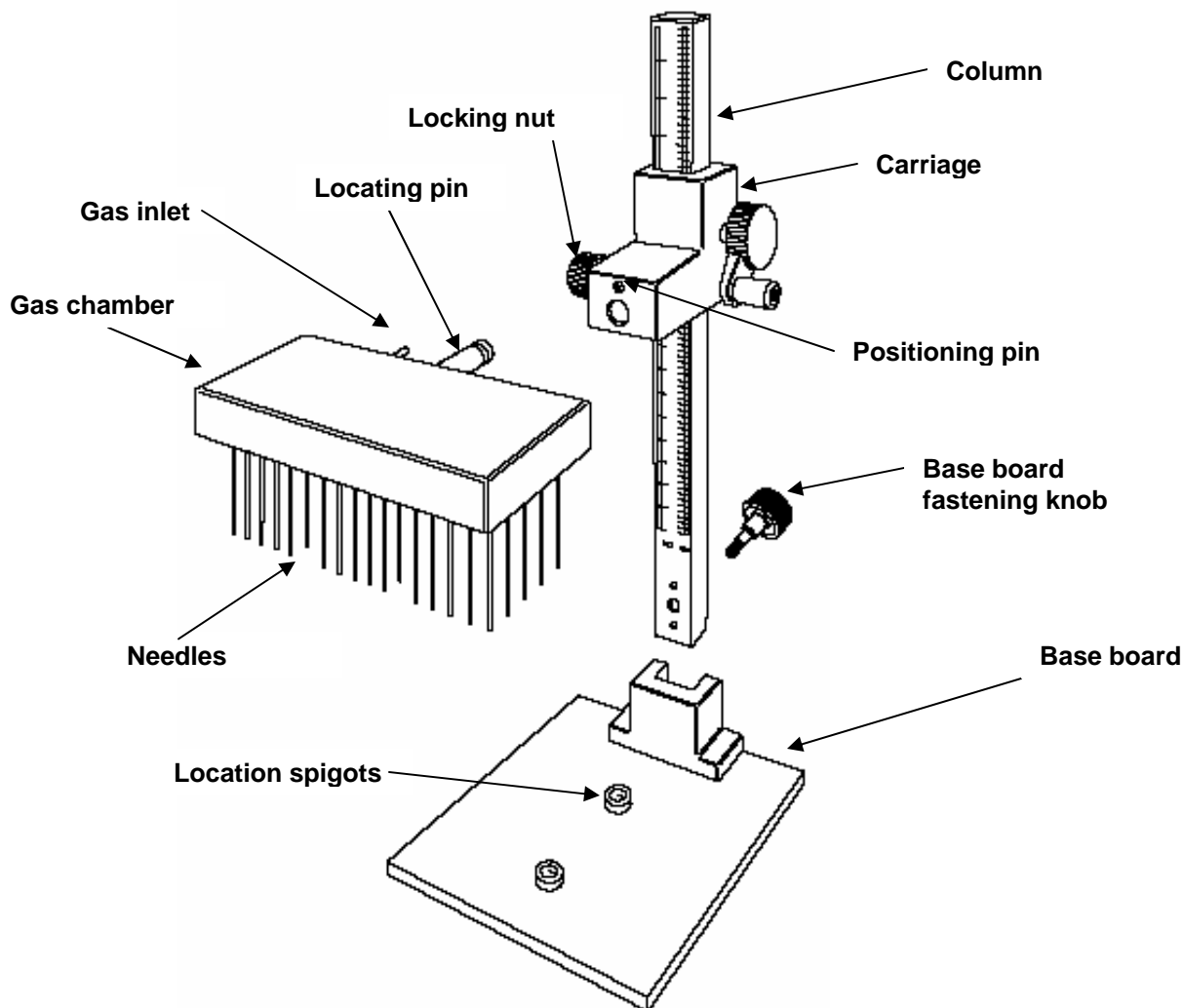

Setup for Operation

Connect the intake nozzle at the rear of the gas chamber to a suitable supply of gas. The gas should flow through a pressure reducing valve prior to connection to the gas chamber. Gas pressure should not exceed 2 psi at the inlet valve of the gas chamber. Position your Stuart block heater on the base board, locating the two pins on the bottom of the block heater onto the two location spigots on the base board. It is important that the block heater is properly located to prevent misalignment of the needles later. The aluminium blocks should be centrally located within the block heater, use the spacers provided.

Loosen the locking knob of the carriage and remove the gas chamber, lay the chamber upside down on a level work surface. The needle matrix in the gas chamber has been designed to accommodate needles in various patterns to suit the different sample configurations of the aluminium blocks. Each configuration has been labelled A through F, please consult the guide below to know which configuration is appropriate for your aluminium blocks. As an example, if you are using three SHT1/16 blocks for twelve 16mm tubes, you would need to insert needles in all holes labelled C and all holes labelled D.

Tube Size and Number	Insert Block code	Hole label
0.5ml (6mm) x 30	SHT1/30	A
1.5ml (10mm) x 20	SHT1/22	B
2ml (12mm) x 20	SHT1/20	B
13mm x 20	SHT1/13	B
16mm x 12	SHT1/16	C & D
19mm x 8	SHT1/19	D, E & F
25mm x 6	SHT1/25	D & E
25mm x 6	SHT1/25	D & E
28mm x 6	SHT1/28	D & E

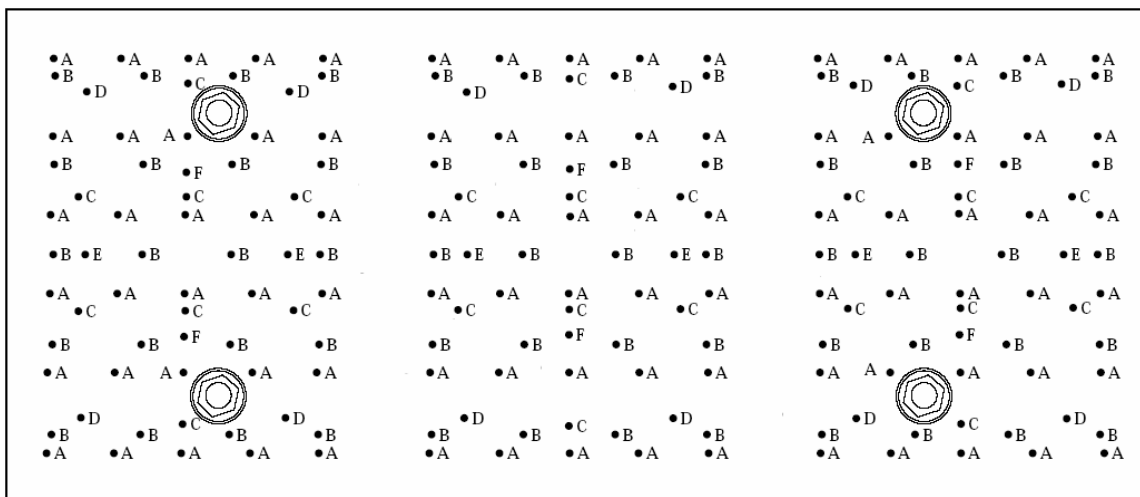

To insert the needles, press each needle firmly, pointed end first, through the relevant guide hole with enough pressure to pierce the sealing membrane behind. The gas chamber membrane is self sealing so needles can be removed and replaced several times. Only use needles where samples will be placed or gas will be wasted. Replace the gas chamber onto the carriage and tighten via the locking nut.

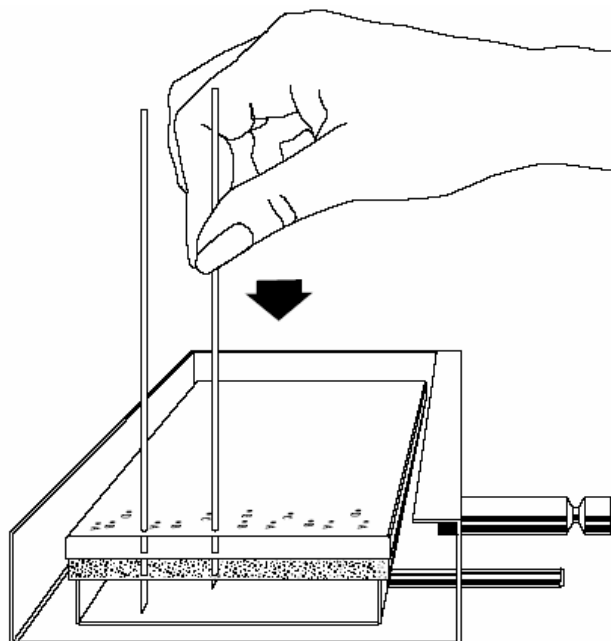

Operation SBH CONC/1

Use the carriage handle to raise the needles to the highest point away from the block heater, insert your sample test tubes into the block heater. Carefully lower the needles into your sample tubes, using the carriage handle. Position the needles at the required height above the liquid surface, take care not to lower the needles into your samples. Set the block heater to the desired temperature and switch on the gas supply, taking care not to exceed 2 psi. To further speed up evaporation, the height of the needles can be gradually lowered as the sample volume reduces. On completion switch off the gas flow and raise the chamber out of the way. Take care the needles may be hot at this point. Operation of your Stuart block heater will be detailed in the manual supplied with it, if further copies are required these can be downloaded at www.barloworld-scientific.com.

Maintenance & Servicing

Periodically clean the instrument using a damp cloth and mild detergent solution. Do not use harsh or abrasive cleaning agents.

Carriage Friction

The carriage works by means of a friction drive. To allow for wear the friction pressure can be increased by tightening the four screws at the back of the carriage. All four screws must be tightened equally. The membrane within the gas chamber is self-healing, but after continued use you may start to notice that it isn't performing as efficiently as it was. Spare pads are available and can be fitted by following the instructions below: Remove the gas chamber from the carriage, disconnect the gas pipe and place the chamber upside down on a flat surface. Remove the four nuts from the corners of the matrix plate, lift off the matrix plate leaving the four spacers in position. Lift off the sealing pad, ensuring that the support strip and spacers remain in position. Replace the pad with the new one and follow the reverse procedure to reassemble the gas chamber.

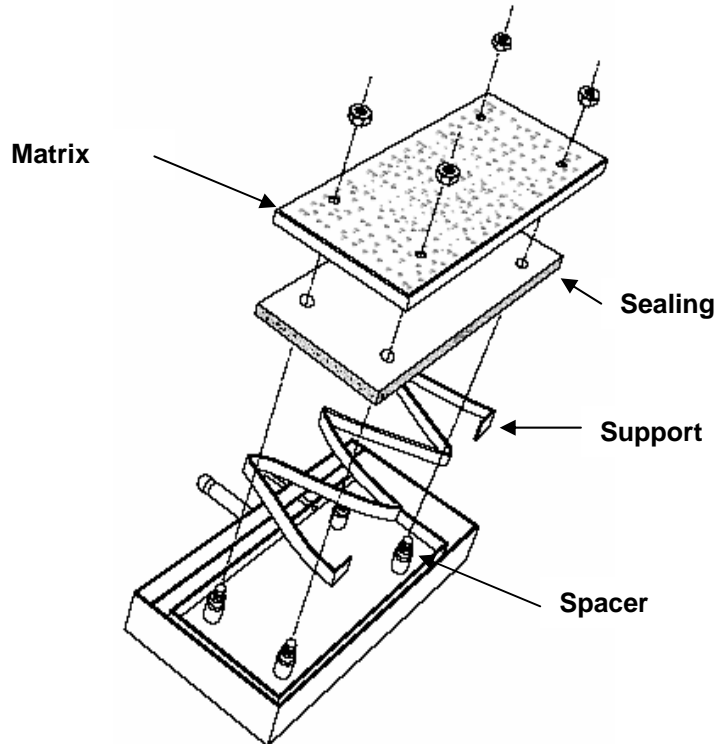

The following spares and accessories are available from your laboratory dealer.

Description	Catalogue Number
F7209	Needles, 76mm (pack of 100)
F7210	Needles, 127mm (pack of 100)
FSC4NCS	Needles, 76mm PTFE coated (pack of 100)
FSC4NCL	Needles, 127mm PTFE coated (pack of 100)
6101609	Base board
6101608	Spigot
6101604	Sealing pad
6101606	Spacer
6101605	Support strip



Thank you for reading this data sheet.

For pricing or for further information, please contact us at our UK Office, using the details below.



UK Office

Keison Products,

P.O. Box 2124, Chelmsford, Essex, CM1 3UP, England.

Tel: +44 (0)330 088 0560

Fax: +44 (0)1245 808399

Email: sales@keison.co.uk

Please note - Product designs and specifications are subject to change without notice. The user is responsible for determining the suitability of this product.