

---

**TECHNE**

**AB-100 & AB-500  
Afterburners**

**OPERATOR'S MANUAL**

## CONTENTS

	<b>PAGE</b>
INTRODUCTION	1
SPECIFICATION	3
OPERATOR SAFETY	4
GUARANTEE	4
CONTACT INFORMATION	5
INSTALLATION	6
COMMISSIONING	7
SETTING THE EXTRACTION SYSTEM	8
OPERATION	9
MAINTENANCE	9
FAULT FINDING	9
ILLUSTRATION OF AB-100	10
WIRING DIAGRAM	11

## INTRODUCTION

The Techne Afterburners AB-100 & AB-500 are designed to reduce smoke emission from the exhaust gas flue of certain sized techne fluidised bath cleaning systems. The Afterburner consists of a burner plate mounted within a thermally insulated combustion chamber. The input to the combustion chamber is designed to mate directly to a standard Techne extraction fan, while the output is suitable for connection to an insulated exhaust stack.

The system is designed and built to comply with British Gas Council regulations, and has an approved flame control unit, which monitors the flame via a flame probe.

The gas train consists of a pilot line pressure regulator, a control solenoid, a gas flow adjuster and a pilot burner running in parallel with a main line pressure regulator, two control solenoid valves in series, a gas flow adjuster, a maximum flow limiter and the main burner.

A safety interlock, in the form of a differential air pressure switch which monitors air flow across the burner, inhibits operation of the burner upon loss of air flow.

The start up sequence for the burner is as follows:-

With the fume extraction fan running, and the Afterburner power switch in the ON position, (it is normal practice to wire the electrical supply to the Afterburner via an auxiliary contact of the extraction fan motor starter), after a pre-purge period of approximately 10 seconds both the ignition system and the pilot solenoid valves are energised. Once the flame probe has detected that the pilot flame is correctly established, the ignition system is switched off and the burner operates on the pilot flame only for a period of approximately 15 seconds, after which the main solenoid valves are energised to establish the main flame.

If the pilot flame is not established correctly during the start-up sequence, the lock out safety circuit causes the burner to shut down to a safe position. Shut down will occur within 5-6 seconds, after the initial release of gas.

The lock out lamp on the control panel will illuminate and the burner cannot be restarted until the START switch has been depressed.

A compulsory minimum delay of 60 seconds is provided by the flame control system before the unit can be re-started. This delay allows the Afterburner to be purged of any combustible gases which may be present.

If during normal operation the gas burner flame is extinguished, the flame probe reacts instantly to the loss of the flame. The solenoid valves are switched off immediately and after a delay period of approximately 10 seconds, the ignition system and the pilot solenoid are energised in an attempt to re-establish the flame in the normal manner.

If the re-light attempt is unsuccessful, the flame control system goes to a lock out state as described above.

The Techne Afterburner system is one of several fume treatment components that may be used in conjunction with Techne fluidised bath cleaning systems. The components selected will depend upon the

materials being treated and the working environment. A brief description of the components is as follows:-

Cyclone assemblies to remove the majority of any fluidised medium that may become entrained in the extracted fumes. The cyclone(s) are positioned in the exhaust ductwork directly after the fluidised bath so that the fluidised medium is removed from the fumes before it contaminates other fume treatment equipment.

A filter assembly to remove any fine particles of fluidised medium and any non-organic particles such as paint pigments or fillers that may be present in the extracted fumes. The filter assembly is positioned in the exhaust ductwork directly after the cyclone(s).

A liquid scrubber to remove any corrosive acids and other soluble noxious fumes (especially hydrochloric acid and harmful by products of PVC and other halogenated polymers) from being emitted into the atmosphere. The scrubber is positioned in the exhaust ductwork after the cyclone(s) (and filter if used), but before the extraction fan.

An extraction fan to direct any fumes generated in the fluidised bath through the various fume treatment components. The extraction fan is positioned in the exhaust ductwork after the cyclone(s) (and filter and scrubber, if used), but before the Afterburner.

In addition, the exhaust ductwork should contain a damper valve to enable the rate of fume removal to be adjusted according to system requirements. A dilution tee should be positioned between the fluidised bath and the cyclone(s) to be optimised and to ensure that the oxygen content of the exhaust fumes is sufficient to obtain stable combustion within the Afterburner.

The exhaust ductwork should be designed to have a minimal pressure drop and should be as short as possible with the minimum of bends. Some polymers produce oil vapour when thermally decomposed, these oils can condense on the walls of the ductwork where they combine with any particular matter and may eventually block the ductwork or the cyclone(s). It is therefore important to ensure that the ductwork can easily be dismantled for cleaning. In applications where the formation of oils cause serious ductwork problems, the ductwork may be thermally insulated to reduce the level of condensation.

The exhaust stack from the outlet spigot of the Afterburner to atmosphere should be suitable for operation with exhaust temperatures in the order of 450°C. A stainless steel lined double walled insulation stack is suggested. The stack should be fitted with a weather-proof termination where it terminates to atmosphere.

## SPECIFICATION

### AB-100

Overall external dimensions (approx)	Height	2170mm
	Width	740mm
	Depth	880mm
	Outlet spigot	203mm
Burner rating	3kW to 60kW 10,000BTU/hr to 200,000BTU/hr	
Fuel consumption range		
Natural gas	0.3m <sup>3</sup> /hr to 6m <sup>3</sup> /hr (10 to 200 ft <sup>3</sup> /hr)	
Butane	0.1m <sup>3</sup> /hr to 2.6m <sup>3</sup> /hr (3 to 60 ft <sup>3</sup> /hr)	
Propane	0.13m <sup>3</sup> /hr to 2.6m <sup>3</sup> /hr (4.5 to 90 ft <sup>3</sup> /hr)	
Gas supply pressure		
Natural gas	1.5kPa to 2.5kPa (6-10 inch WG)	
Butane	2.5kPa to 3.5kPa (10-14 inch WG)	
Propane	2.5kPa to 3.5kPa (10-14 inch WG)	

### AB-500

Overall external dimensions (approx)	Height	2500mm
	Width	1200mm
	Depth	1000mm
	Outlet spigot	305mm
Burner rating	6kW to 120kW 20,000 BTU/hr to 400,000 BTU/hr	
Fuel consumption range		
Natural gas	0.6m <sup>3</sup> /hr to 12m <sup>3</sup> /hr (20 to 400 ft <sup>3</sup> /hr)	
Butane	0.2m <sup>3</sup> /hr to 4m <sup>3</sup> /hr (6 to 120 ft <sup>3</sup> /hr)	
Propane	0.26m <sup>3</sup> /hr to 5.2m <sup>3</sup> /hr (9 to 180 ft <sup>3</sup> /hr)	
Gas supply pressure		
Natural gas	1.5kPa to 2.5kPa (6-10 inch WG)	
Butane	2.5kPa to 3.5kPa (10-14 inch WG)	
Propane	2.5kPa to 3.5kPa (10-14 inch WG)	

### Both Units

Exhaust gas temperature	Typically 450°C
Electrical Supply	220/240V 1PH 50/60Hz

## **OPERATOR SAFETY**

All users of Techne equipment must have available the relevant literature needed to ensure their safety.

It is important that only suitably trained personnel use this equipment, in accordance with the instructions contained in this Operator's Manual and with general safety standards and procedures. If the equipment is used in a manner not specified by Techne the protection provided by the equipment to the user may be impaired.

The unit has been designed to conform to international safety specification.

## **GUARANTEE**

This instrument is guaranteed against any defect in material or workmanship for a period as specified on the enclosed guarantee card. This period is from the date of purchase, and within this period all defective parts will be replaced free of charge provided that the defect is not the result of misuse, accident or negligence. Servicing under this guarantee should be obtained from the supplier.

Notwithstanding the description and specification(s) of the units contained in the Operator's Manual and Service Manual, Bibby Scientific Limited hereby reserves the right to make such changes as it shall see fit to the units or to any component of the units. This Service Manual has been prepared solely for the convenience of Bibby Scientific Limited customers and nothing in this Service manual shall be taken as a warranty, condition or representation concerning the description, merchantability, fitness for the purpose or otherwise of the units or the components.

## INSTALLATION

Mount the Afterburner in a convenient position adjacent to the fluidised bath ensuring that sufficient space is left around the Afterburner for access during maintenance. In particular access to the front of the Afterburner is required to enable the burner plate to be removed for cleaning if required.

Connect the lower input spigot to the output of the fume extraction fan. The ductwork between the output duct of the fluidised bath and the input to the extraction fan should be generally in line with recommendations covered in the earlier General Description section of this manual.

Connect the output spigot to a suitable insulated exhaust stack directed to atmosphere (see General Description section).

### **AB-100**

Connect a suitably sized gas main to the 3/4" BSP input connection below the control/gas train console, positioning a lockable manual shut-off valve close to the Afterburner to ensure safety during maintenance periods, etc.

### **AB-100**

Connect a suitably sized gas main to the 2" BSP input connection below the control/gas train console, positioning a lockable manual shut-off valve close to the Afterburner to ensure safety during maintenance periods, etc.

Connect a single phase electrical supply to the input terminals in the control cabinet, see rating plate for details. The base of the control cabinet may be machined to accept suitable conduit. The electrical supply to the Afterburner should be interlocked with the motor starter of the extraction fan (see General Description and circuit diagram).

Connect the low pressure side of the differential air pressure switch (terminated at the rear of the Afterburner) to the ducting just prior to the input of the extraction fan using 5/16" OD copper tubing or a suitable alternative. The differential air pressure switch monitors the pressure drop across the extraction fan in its normal working mode and is intended to switch off the Afterburner when the exhaust gas flow ceases due to a blocked flue or seized fan impeller, etc.

Purge the gas supply line to the burner by removing the 1/8" BSP plug from the main gas train situated between the pressure regulator and first main gas solenoid valve.

Remove the inspection panel containing the sight glass and ensure that the burner plate is clean and free of any swarf or insulation material.

## COMMISSIONING

With the extraction fan switched on and operating in the correct direction, ensure that the gas supply is turned on at the remote manual shut off valve (if fitted in supply line), and that an input gas pressure of greater than 6 inches is registered on the input gas pressure gauge.

With the main gas flow regulating valve (situated in the main gas line prior to the burner but within the gas train console) in the OFF position, switch the power switch to the ON position.

The fan failure neon should be extinguished. If the neon is illuminated, check the operation of the extraction fan and the connections between either side of the differential pressure switch and the ductwork/base of the Afterburner. The operating position of the differential switch may be adjusted if required by removing the yellow plastic plug on the side of the switch body and rotating, the internal screw.

When the fan failure light is extinguished, the automatic start up sequence should commence, as detailed in the General Description of this manual.

It is not common for the burner to initially fail to ignite due to the air within the gas supply line or an incorrectly set pilot flame adjuster. If the flame control system goes into a lock-out mode, leave for approximately 60 seconds with the power switch in the ON position before depressing the start button to re-initiate the start up procedure.

The pilot light adjuster needs to be used either to establish a flame initially or to modify the flame. Remove the end cap of the pilot light adjuster, situated above the main gas flow manual adjusting valve, and adjust the internal screw. A pilot flame of sufficient size to successfully sustain the flame control system in the ON position is needed.

Once the pilot flame has been successfully established and detected by the flame probe, the main gas solenoid valves will be heard to open as they are energised.

The main gas flow limiter, or ballofix valve, adjacent to the main gas flow valve, should initially be set in the fully open position.

Opening the main gas flow adjusting valve should establish the main burner flame. Adjustment to the size of the flame and the setting of the gas flow limiter should be attempted during a cleaning cycle in the fluidised bath. Under conditions where the maximum fumes are generated within the fluidised bath the flame should be adjusted and may also be limited such that acceptable fume emission from the exhaust stack is achieved.

Adjustable profile plates are situated either side of the burner plate within the combustion chamber. These plates may be moved towards or away from the burner plate so as to achieve ideal contact between the flame and the fumes being treated with the minimum pressure drop within the system.

Adjustments built into the ductwork system as described in the General Description section of this manual allow the fume treatment system to be tuned according to system requirements. However, adjustments tend to be interactive, the best results being usually obtained by trial and error.

The ducting damper valve may be used to reduce the overall extraction flow rate, which reduces the gas consumption of the exhaust fumes. However, the fume extraction flow rate must be high enough to entrain any fumes produced during the cleaning process.



The dilution tee may be used to ensure that the oxygen content of the exhaust is high enough to maintain the burner flame during the smoke cycle. The dilution tee also enables the velocity in the cyclone to be maintained at a suitable value to ensure efficient separation of any fluidising medium, while the velocity in the fluidised bath exhaust duct may be limited to reduce the amount of fluidising medium entrained.

A correctly adjusted system should result in a minimal loss of fluidising medium from the fluidised bath. The majority of the entrained medium should be retained by the cyclone, from where it may be returned to the bath. The fume concentration within the ducting should be below the LEL (lower explosion limit) for the various products generated during the cleaning process. The exhaust emission from the Afterburner outlet should be within locally acceptable limits. The environment adjacent to the fluidised bath should have gas concentrations within locally accepted TLV (threshold limit values).

### SETTING THE EXTRACTION SYSTEM

1. Switch on the extraction system setting the dampers initially as follows:  
Dilution Tee 50%  
Damper 50%
2. Heat up the bath to the working temperature, adjusting the air flow for correct fluidisation.
3. When at the working temperature, adjusting the damper so that any fine dust particles omitted from the surface of the bath are just entrained by the extraction system.
4. Operate as above for 30 minutes.
5. Switch off the extraction system and check:
  - a. The amount of sand in the collector bin (cyclone)
  - b. The amount of sand in the duct
6. If there is more than 2" of sand in the bin ensure that fluidisation is not excessive and that the bath was not overfilled. Tip the sand back into the bath.
7. If 6 is satisfactory check that the extraction rate is not excessive.

#### **NOTE: IF A LID IS USED ON THE BATH, ENSURE THAT IT IS NOT AIRTIGHT**

8. If there is sand in the Afterburner the velocity through the cyclone is incorrect. Therefore open the dilution tee and increase damper so that system still just entrains fines. Re-check the system from 4.
9. Check the operation of the afterburner. Set the flame to maximum (gate valve fully open).
10. With the Afterburner running immerse **slightly** contaminated component.
11. Check fume extraction above the bath visibly ensuring all fumes are extracted ie: Drager to check concentration. Check the Lower Explosive Limit.
12. Check the visible smoke from the stack, check the fume concentration is acceptable.
13. If the visible smoke is present or the fume concentration is too high decrease the smoke generation rate, ie: reduce the temperature of the bath.
14. When 11 is satisfactory, immerse a maximum contamination item and re-check as 11.
15. Repeat 14 and decrease the flame size until conditions are just acceptable to minimise gas consumption.

## OPERATION

The Afterburner may be used either continuously during cleaning operations in the fluidised bath or, to reduce the overall gas consumption, during the initial part of the cleaning cycle when visible fumes are provided.

With the electrical and gas supplies to the Afterburner switched on, the burner may be initiated by switching the power switch to the ON position. The automatic start-up sequence (as described in the General Description section of this manual) will commence, and after the appropriate time delays the main burner flame will ignite.

Should the system fail to ignite, or for some reason the burner flame be extinguished during operation, the control system will go into lock-out state. A delay of approximately 60 seconds occurs in this state before it is possible to recommence the start-up sequence by depressing the start button.

To stop the Afterburner at any time, switch the power switch to the OFF position.

## MAINTENANCE

The following points should be checked as part of a regular maintenance routine. The period between checks depends upon the types of materials being treated in the fluidised bath and the frequency at which the system is used.

- a. Check ignition electrode, clean and replace as necessary.
- b. Check the condition of the burner plates, and clean if necessary.  
**Note:** excessive deposits of fluidising medium on the burner plate are an indication of poor system adjustment or incorrect maintenance of the cyclone.
- c. Check the condition of the thermal insulation within the combustion chamber, damaged insulation should be replaced before the outer casing of the Afterburner is subjected to high temperatures.
- d. Check the condition of the flame probe, clean and replace as necessary.
- e. Check the function of the flame control system.

## FAULT FINDING

### 1. Burner will not start

- a. Check for electrical supply at burner control terminal 9. This will prove air pressure switch is operational.
- b. Check that the control is not in the lock-out position.

### 2. Burner starts but control goes to lock-out

- a. Check that gas supply is turned ON.
- b. Check that flame sensing probe is correctly positioned and not shorting to earth.
- c. Check ignition circuit is functioning correctly, ie: transformer or spark plug is not shorting to earth.

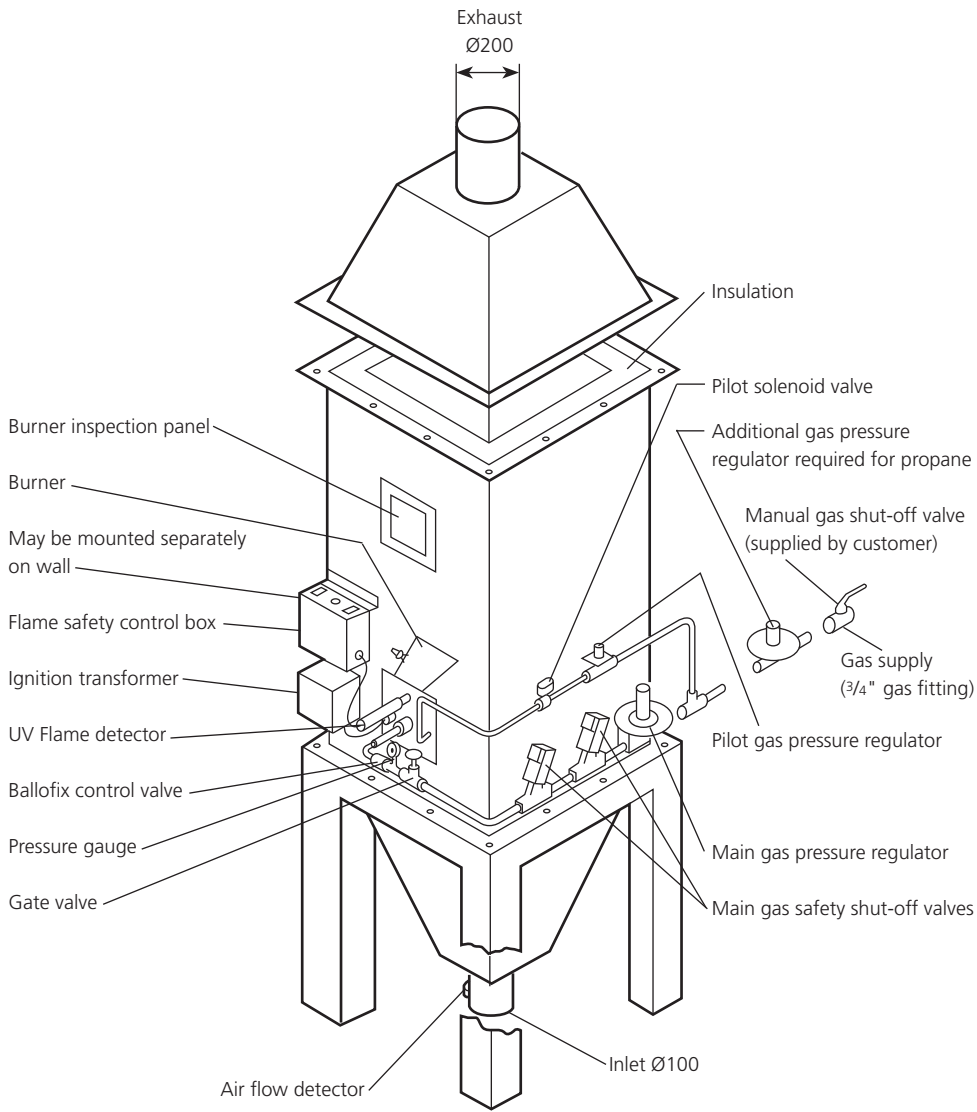

AB 100

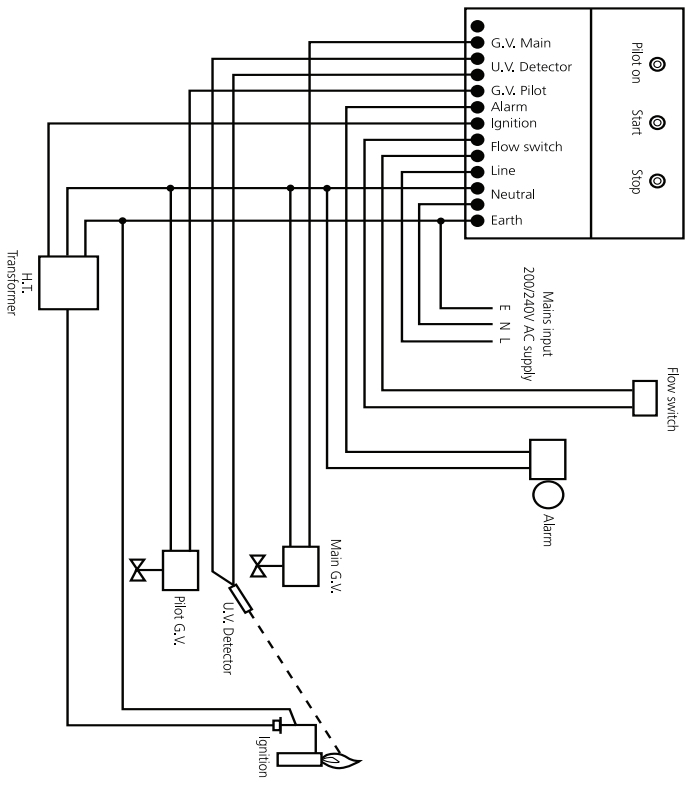
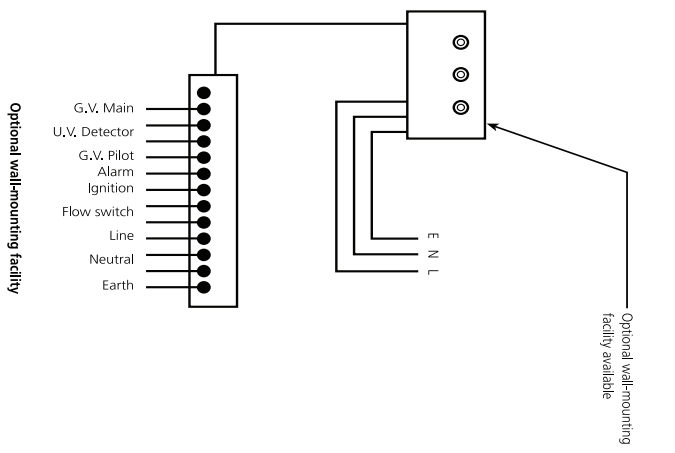

AB 100 WIRING DIAGRAM



Thank you for reading this data sheet.

For pricing or for further information, please contact us at our UK Office, using the details below.



**UK Office**

**Keison Products,**

**P.O. Box 2124, Chelmsford, Essex, CM1 3UP, England.**

**Tel: +44 (0)330 088 0560**

**Fax: +44 (0)1245 808399**

**Email: [sales@keison.co.uk](mailto:sales@keison.co.uk)**

Please note - Product designs and specifications are subject to change without notice. The user is responsible for determining the suitability of this product.