



VEGAVIB 62



Vibrating level switch for granular bulk solids with suspension cable

Application area

VEGAVIB 62 is used as a level switch in granular and coarse-grained bulk solids and detects reliably and accurately when the min. or max. level is reached. The optimum rod design avoids buildup and jamming by the bulk solid material.

Advantages

- Simple setup without adjustment
- Product-independent switching point
- Optimum rod design avoids buildup and jamming by the bulk solid
- Easy cleaning
- Wear and maintenance-free
- SIL qualified

Function

The vibrating rod of VEGAVIB is energized via the piezo drive to vibrate at its resonance frequency. When covered with medium, the amplitude of the vibrating rod is damped. This change is detected by the electronics and converted into a switching signal.

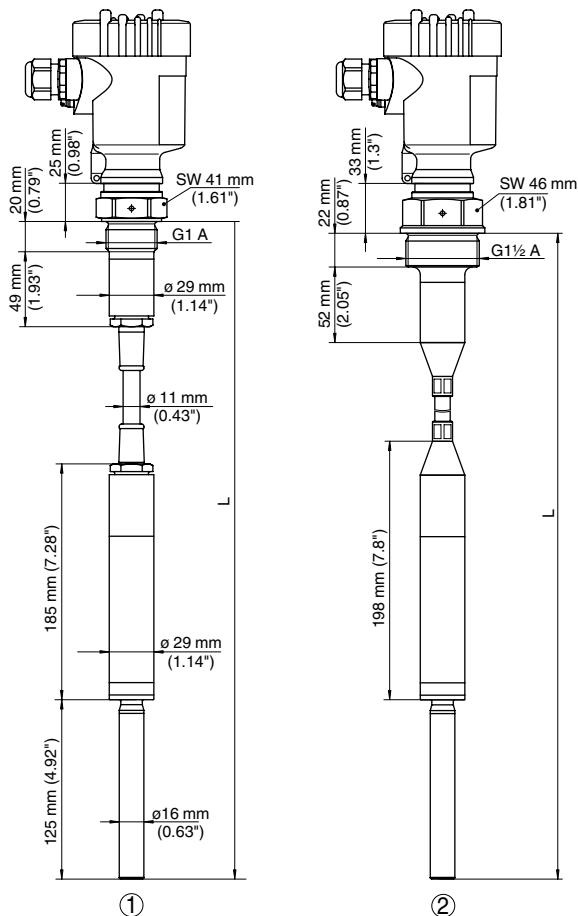

- 1 Version with PUR suspension cable
- 2 Version with FEP suspension cable

Approval

- XX** without
- CX** ATEX II 1G, 1/2G, 2G Ex ia IIC T6
- CK** ATEX II 1,1/2,2G Ex ia IIC T6+1,1/2,2D Ex tD IP66 T*
- CI** IECEx Ex ia IIC T6
- GX** ATEX II 1,1/2,2D Ex tD IP66 T*

Version / Process temperature

- T** Cable PUR / -20...80°C
- H** Cable FEP / -40...150°C
- C** Detection of solids in water / -20...80°C

Process fitting / Material

- GC** Thread G1 (DIN 3852-A) PN6 / 316L
- NC** Thread 1NPT (ASME B1.20.1) PN6 / 316L
- GD** Thread G1½ (DIN 3852-A) PN6 / 316L
- ND** Thread 1½NPT (ASME B1.20.1) PN6 / 316L
- EF** Flange DN50PN40 Form C,DIN2501/316L
- KF** Flange DN80PN40 Form C,DIN2501/316L
- MF** Flange DN100PN16 Form C,DIN2501/316L
- HA** Flange 2"150lb RF,ANSI B16.5; 316L
- OA** Flange 3"150lb RF,ANSI B16.5/316L

Electronics

- C** Contactless electronic switch 20...253VAC/DC
- R** Relay (DPDT) 20...72VDC/20...253VAC(3A)
- T** Transistor (NPN/PNP) 10...55VDC
- Z** Two-wire 8/16 mA 10...36VDC
- N** NAMUR signal

Housing / Protection

- K** Plastic / IP66/IP67
- A** Aluminium / IP66/IP68 (0.2 bar)
- 8** StSt (electropolished) 316L / IP66/IP68 (0.2bar)

Cable entry / Cable gland / Plug connection

- M** M20x1.5 / with / without
- N** ½NPT / without / without

Additional equipment

- X** without



Length (from seal surface)

PUR (480-80000 mm) per 100 mm
 FEP (480-80000 mm) per 100 mm



Thank you for reading this data sheet.

For pricing or for further information, please contact us at our UK Office, using the details below.



UK Office

Keison Products,

P.O. Box 2124, Chelmsford, Essex, CM1 3UP, England.

Tel: +44 (0)330 088 0560

Fax: +44 (0)1245 808399

Email: sales@keison.co.uk

Please note - Product designs and specifications are subject to change without notice. The user is responsible for determining the suitability of this product.