

NEW

YOKOGAWA 

Handy Calibrators

CA11E / CA12E

CA11E Voltage/Current Calibrator

CA12E Temperature Calibrator

Both signal source and measurement functions

Simple operation, easy to use

Lightweight, compact body

- NEW** Display resolution for current 0.001mA (**CA11E**)
- NEW** Addition of loop check function (**CA11E**)
- NEW** Source/measurement of 10 kinds of thermocouples (**CA12E**)
- NEW** Addition of rubber boot as accessory



Yokogawa Meters & Instruments Corporation

Bulletin CA10-E

Compact, Low Cost, Versatile



Features

Source and Measuring of Voltage and Current

Generates and measures voltages up to 30 V DC and currents up to 24 mA DC.

Improved display resolution for current

NEW

The generation/measurement resolution has improved to 0.001 mA.

24 V (20 mA)/Loop check function*

Enables measurement of generated current signals while supplying loop power to two-wire transmitter.

NEW

* Load current: Max. DC22 mA

20 mA SINK Function

Absorbs the voltage supplied from an external power supply to its H terminal and simulates a two-wire transmitter making it ideal for loop checks.

4-20 mA and 1-5 V DC Step-up/down Function

The output level can be changed between 4↔8↔12↔16↔20 mA signals by one touch for the 4-20 mA DC output, and between 1↔2↔3↔4↔5V signals for the 1-5 V DC output, for efficient calibration work.

4-20 mA Step-up/down Output

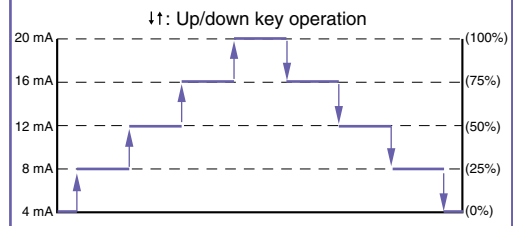

Sweep Function

Increases and decreases the output level to the preset level at a constant rate for the selected sweep time (16 or 32 seconds). The sweep function and sweep time are set by the internal dip switches.

Panel Design Common to All Models

Power Switch

Up/Down Keys

Used to set the output signal level. A pair of up/down keys is conveniently located immediately below each digit in the LCD panel.

Output On/Off Switch

(Output signal can set ON/OFF)

Range Selection Rotary Switch

The rotary switch simplifies range selection: just leave the switch set to the most frequently used range.

Source/Measure Selection Switch

Temperature Calibrator CA12E



■ Features

■ **Simulator of Common Thermocouples and RTD Sensors**
Outputs a signal equivalent to signals of ten types of thermocouple K, E, J, T, N, S, B, L, M and R as well as Pt100 resistance temperature detector. Suitable for a broad range of applications such as maintenance of industrial process instruments and various thermometers.

■ Multi-range Thermometer

Can be used as a multi-range thermometer. Three-wire RTD connection for an RTD is possible.

■ Built-in Sensor for Reference Junction Compensation

Reference junction compensation when generating a thermocouple signal can be performed by the built-in temperature sensor. For more precise compensation, use the external RJC sensor (model B9108WA, sold separately).

■ Shift Key

Selects "temperature" or "RTD" unit.

■ Terminal Adapter

Provides screw terminals for connecting a temperature sensor such as a thermocouple and RTD when measuring temperature. When generating an RTD signal, a three-wire RTD signal can be output using the lead cables that come with the CA12E by short-circuiting the Lo-Lo terminals using the short-circuit bar that also comes with the CA12E.

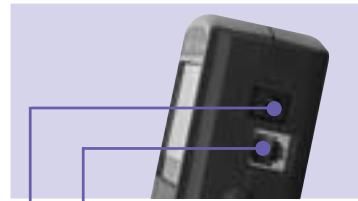

■ Plug for External RJC Sensor

The RJC sensor is sold separately.

■ Plug for AC Adapter

Common for all CA11E, CA12E

■ Example of Use of Terminal Adapter

(When outputting a three-wire RTD signal)

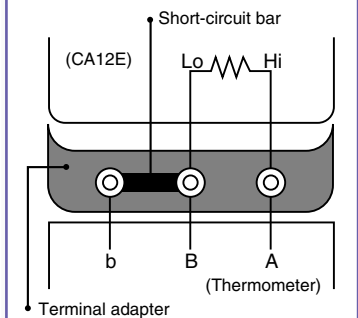

■ General/Common Specifications for CA11E/CA12E

Power supply	: Four 1.5-V alkaline batteries (ANSI AA-size) or dedicated AC adapter (sold separately)	Measurement display	: Approximately 1 update/sec.
Life of Batteries	: CA11E : Approximately 50 hours for 5 V DC output (with a load of 10kΩ or greater) Approximately 25 hours for 20 mA DC output (with a load of 5 V) CA12E : Approximately 55 hours * When generating a signal continuously on alkaline batteries	update interval	: Approximately 1 update/sec.
Automatic Power-off	: Approximately 10 minutes (Can be canceled by DIP switch setting)	Display	: 7 segments LCD
Generation Signal Level Setting	: By four-digit up/down keys	Operating temperature/ humidity range	: 0 to 50°C and 20 to 85%RH (no condensation)
Response of generator	: CA11E : Approximately 1 second (from when the output begins to change until when the output level falls within the specified accuracy) CA12E (400Ω and RTD range) : Approximately 20 milliseconds (from when the specified current is applied until when the output level falls within the specified accuracy)	Storage temperature/ humidity range	: -20 to 50°C and 90%RH or less (no condensation)
Maximum Allowable Applied Voltage	: CA11E: 30 VDC or less between each terminal and ground CA12E: 42 V peak or less between each terminal and ground	Dimensions	: Approximately 192 (W) × 92 (H) × 42 (D) mm (Excluding protrusions)
		Weight	: Approximately 440 g (including batteries)
		Accessories	: Lead cable (1 pair) Terminal adapter (for CA12E only) (1) Instruction manual (1) 1.5-V alkaline battery (ANSI AA-size)(4) • For suffix code -1 Carrying case (1) • For suffix code -2 Rubber boot (1) Strap (1) Accessory case (1)

Examples of Applications

Application Example of CA11E (Transmitter Simulation 1)

New function

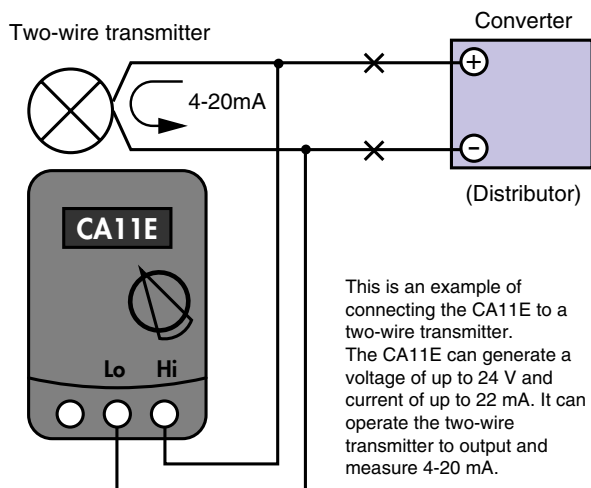

An Application of CA12E (RTD Simulation)

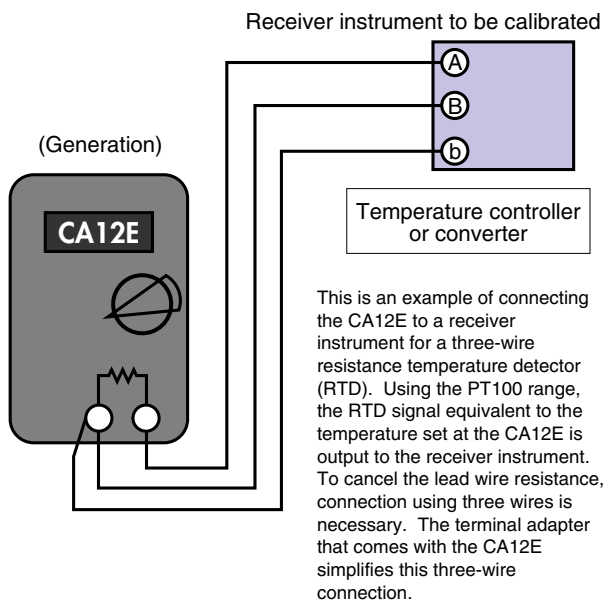

An Application of CA11E (Transmitter Simulation 2)

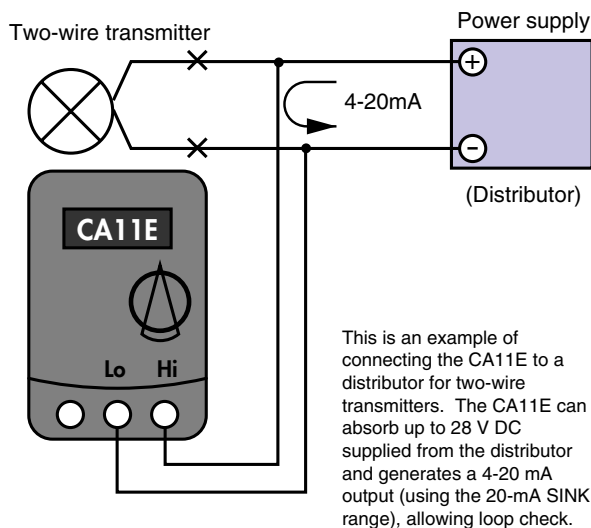

Application Example of CA12E (Generation of thermo-electromotive force)

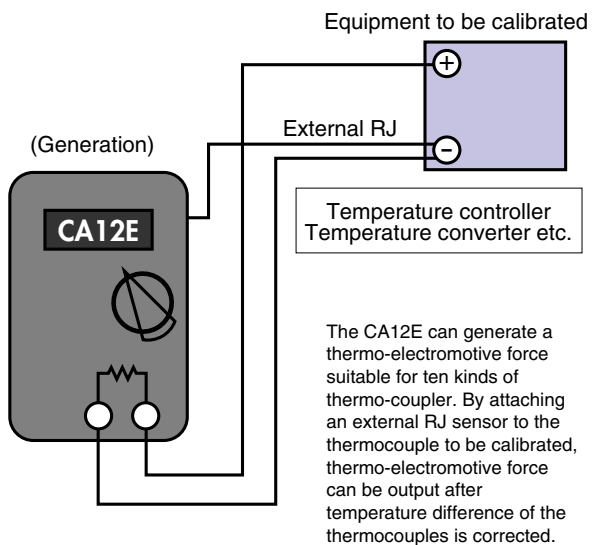

■ Additional Features

Choose either "rubber boot" or "carrying case"

Rubber boot, strap and accessory case can be chosen as standard accessories to improve impact resistance and make it easier to carry. (The calibrator cannot be stored in the carrying case when the rubber boot is attached.)

NEW

The roomy case easily holds the calibrator without having to disconnect the lead cables.

Rubber boot (93038)



Strap (97040)



Allows the calibrator to be hung on a wall.

Accessory case (B9108XA)



Used to store probes and accessories.

carrying case (B9108NK)



Automatic Power-off

Power is turned off automatically if the calibrator is not touched for 10 minutes, prolonging battery life.

Simple and Easy Calibration

For the CA11E and CA12E, There is performing calibrations during periodic maintenance as they can be simply calibrated by the up/down keys.

Runs on 1.5 V AA-size Batteries or AC Adapter

The handy calibrators can run on the built-in 1.5-V ANSI batteries or an AC power supply using the AC adapter (sold separately).

Complete Protection (CA11E)

The complete protector protects the circuit against short-circuiting of the voltage output terminals and application of a voltage (of up to 30 V) to the output terminals, etc. due to misconnection.

Longer Lead Cables

The slightly longer than usual lead cables of 1.7 m (approximately 0.1 Ω for both cables) allow easy cable connection even if the handy calibrator is put on the floor.

Dip Switches (inside battery compartment)

Switch Number	CA11E		CA12E	
	ON	OFF	ON	OFF
1	Sweep function	Sweep function -off	The built-in RJC is on.	External RJC is on.
2	32 s	16 s	'F	'C
3	24.00	24.000	PT100-IPTS68	PT100-ITS90
4	Automatic power-off is disabled.	Automatic power-off	Automatic power-off is disabled.	Automatic power-off

Compact and Lightweight

Almost the same size and weight as a hand-held digital multimeter, this calibrator is designed for use in the field.

Model and Suffix Code

Calibrators Model and Suffix Code

Name	Model	Suffix code	Description
Handy CAL	CA11E		voltage/current calibrator
	CA12E		temperature calibrator
		-1	With carrying case(B9108NK)
		-2	With rubber boot(93038), strap(97040), accessory case(B9108XA)

Temperature effect: 1/10 of accuracy/°C; however, for 100-mV range, 0.005% + 10 μV/°C

Accessory

Name	Model	Description
AC adapter	A1020UP	For 100 V
	A1022UP	For 120 V
	B9108WB	For 220-240 V
Reference junction sensor	B9108WA	

Spare Parts

Name	Model	Description
Lead cables	B9108MS	1 pair(1 red and 1 black cables) for CA11E
Lead cables	B9108MT	1 pair(1 red and 2 black cables) for CA12E
Terminal adapter	B9108KF	for CA12E
Carrying case	B9108NK	This spare part is setting with suffix code 01
Rubber boot	93038	This spare part is setting with suffix code 02
Strap	97040	
Accessory case	B9108XA	

Specifications of Each Model

CA11E Voltage/Current Calibrator

Source Functions

Accuracy = ±(% of setting + value in mV, μV, or μA), at 23 ±5°C for one year

Range Selection	Range of Generated Signal	Accuracy	Setting Resolution	Remarks
30 V	0 to 30.00 V	0.05% + 20 mV	10 mV	Maximum current: 1mA
10 V	0 to 11.000 V	0.05% + 2 mV	1 mV	Maximum output current: 10 mA
1-5 V	1/2/3/4/5 V	0.05% + 2 mV *2	1 V step	*2 When the load is 1 kΩ or greater, and the error of the lead cables is excluded
1 V	0 to 1.1000 V	0.05% + 0.2 mV *2	0.1 mV	
100 mV	0.00 to 110.00 mV	0.05% + 50 μV	10 μV	
20 mA *	0 to 24.000 mA	0.05% + 4 μA	1 μA	Maximum load: 12 V
4-20 mA *	4/8/12/16/20 mA	0.05% + 4 μA	4 mA step	
24 V (20 mA) *	24 V	±10%	—	Maximum current: 22 mA
20 mASINK *	0.1 to 24.000 mA	0.1% + 4 μA	1 μA	External power supply: 5 to 28 V

Temperature effect: 1/10 of accuracy/°C; however, for 100-mV range, 0.005% + 10 μV/°C

*1 The display resolution can select 24.000 or 24.00 displays with dip switch.

Measurement Functions

Accuracy = ±(% of reading + value in the least significant digit), at 23 ±5°C for one year

Range Selection	Indication	Accuracy	Resolution	Remarks
30 V	0 to ±30.00 V DC	0.05% + 2 digits	10 mV	Input impedance: Approx. 1 MΩ
10 V	0 to ±11.000 V DC	0.05% + 2 digits	1 mV	
1 V	0 to ±1100.0 mV	0.05% + 2 digits	0.1 mV	
100 mV	0 to ±110.00 mV DC	0.05% + 7 digits	0.01 mV	
20 mA *	0 to ±24.000 mA DC	0.05% + 4 digit	0.001 mA	Input impedance: Approx. 45 Ω

*1 The display resolution can select 24.000 or 24.00 displays with dip switch.

CA12E Temperature Calibrator

Source and Measurement Functions

Accuracy = ±(% of setting or reading + value in °C), at 23 ±5°C for one year

Range Selection	Range of Generated Signal/Indication	Accuracy		Resolution	Remarks	
		Source *4	Measurement *5			
TC **4	K	-200.0 to 1372.0°C	-328 to +2498°F	0.05% + 1°C (>-100°C)	0.07% + 1.5°C (>-100°C)	0.1°C or 1°F
	E	-200.0 to 1000.0°C	-328 to +1832°F	0.05% + 2°C (≤-100°C)	0.07% + 2°C (≤-100°C)	
	J	-200.0 to 1200.0°C	-328 to +2192°F			
	T	-200.0 to 400.0°C	-328 to +752°F			
	N	-200.0 to 1300.0°C	-328 to +2372°F			
	R	0 to 1768°C	+32 to +3214°F	0.05% + 3°C (<100°C)	0.07% + 3°C (<100°C)	1°C or 1°F
	S			0.05% + 2°C (≥100°C)	0.07% + 2°C (≥100°C)	
	B	600 to 1800°C	+1112 to +3272°F	0.05% + 4°C (<1000°C)	0.07% + 4°C (<1000°C)	
				0.05% + 3°C (≥1000°C)	0.07% + 3°C (≥1000°C)	
	L	-200 to 900°C	-328 to +1652°F	0.05% + 0.5°C (<0°C)	0.07% + 1.5°C (<0°C)	
U	-200 to 400°C	-328 to +752°F	0.05% + 1°C (≥0°C)	0.07% + 2°C (≥0°C)		
100mV	0 to ±110.00mV	0.05% + 30 μV	0.05% + 30 μV	10 μV		
RTD PT100 **2 *3 (JPT100)	-200.0 to 850.0°C (-200.0 to 500.0°C)	-328 to +1562°F (-328 to +932°F)	0.05% + 0.6°C *6	0.05% + 0.6°C *7	0.1°C or 1°F	
400 Ω	0 to 400.0 Ω	0.05% + 0.2 Ω *6	0.05% + 0.2 Ω *7	0.1 Ω		

Temperature effect: 1/10 of accuracy/°C

*1 Based on the reference thermal EMF table of JIS C1602-1995

*2 Based on the reference resistance table of JIS C1604-1997.

*3 Based on the international temperature standard 1990 (ITS-90).

*4 The accuracy for generation of thermocouple signals does not include the error of the reference junction compensation. When compensating the output using an RJC sensor, add the accuracy of the RJC sensor. The output compensation is performed every 4 seconds. RJC sensor specifications - measurement range: -10 to 50°C; accuracy(in combination with the CA12E): ±0.5°C at 18 to 28°C and ±1°C at other temperatures.

*5 The accuracy for measurement of thermocouple signals indicates the error against the reference EMF table and includes the error of the internal reference junction compensation when the temperature at the terminals is stable.

*6 External excitation current: 0.5 to 2 mA; add 0.05% + 1°C (or 0.4 Ω) when it is 0.1 mA. Input capacitance of receiver instrument: 0.1 μF or less.

*7 When measuring a temperature using a three-wire RTD.



Thank you for reading this data sheet.

For pricing or for further information, please contact us at our UK Office, using the details below.



UK Office

Keison Products,

P.O. Box 2124, Chelmsford, Essex, CM1 3UP, England.

Tel: +44 (0)330 088 0560

Fax: +44 (0)1245 808399

Email: sales@keison.co.uk

Please note - Product designs and specifications are subject to change without notice. The user is responsible for determining the suitability of this product.