



BFS

High Temperature Fluidised Bath
OPERATOR'S MANUAL

Issue 24.

Date of issue:

3rd May 2005

Techne is a trademark

© Techne, 2003

CONTENTS**BFS Operator's Manual**

	<i>page</i>
SAFETY AND INSTALLATION	
English	4
Français	5
Deutsch	6
Español	7
Introduction	8
Operator Safety	8
Contact Information	8
General Description	9
Technical Specification	11
INSTALLATION	12
OPERATION	15
MAINTENANCE	19
FAULTFINDING	20
Spare Parts	21
Accessories	21
Eurotherm Controller Manual	enclosed

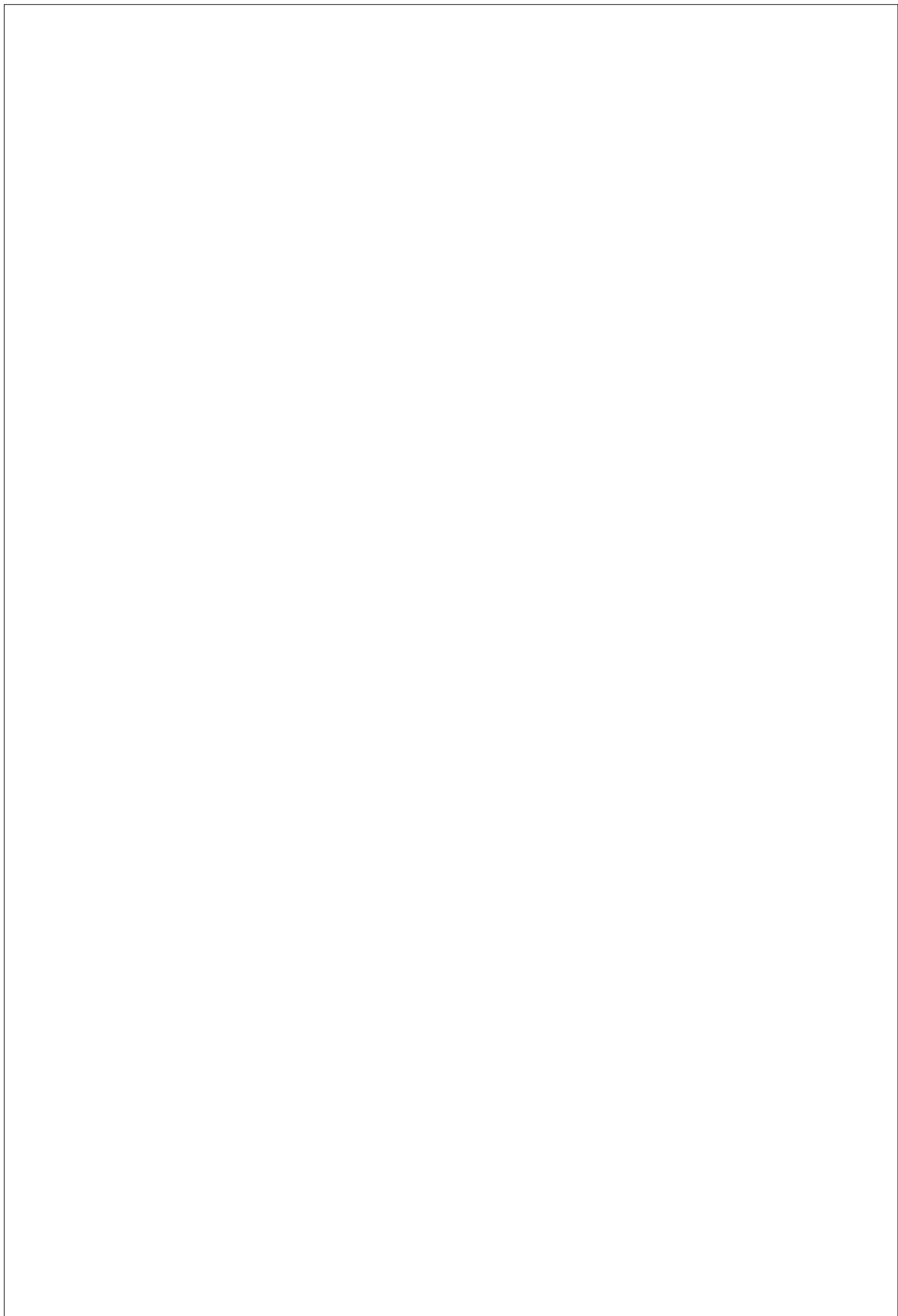

NOTES

Introduction

Please read all the information in this booklet before using the unit.

Warning



HIGH TEMPERATURES ARE DANGEROUS: they can cause serious burns to operators and ignite combustible material.

Techne have taken great care in the design of these units to protect operators from hazards, but users should pay attention to the following points:

- USE CARE AND WEAR PROTECTIVE GLOVES TO PROTECT HANDS;
- DO NOT put hot objects on or near combustible objects;
- DO NOT operate the unit close to inflammable liquids or gases;
- DO NOT place any liquid directly in your unit;
- At all times USE COMMON SENSE.

Operator Safety

All users of Techne equipment must have available the relevant literature needed to ensure their safety.

It is important that only suitably trained personnel operate this equipment, in accordance with the instructions contained in this manual and with general safety standards and procedures. If the equipment is used in a manner not specified by Techne the protection provided by the equipment to the user may be impaired.

All Techne units have been designed to conform to international safety requirements and are fitted with an overtemperature cut-out. On some models, the cut-out is adjustable and should be set to suit the application. On all other models the cut-out is preset to protect the unit.

If a safety problem should be encountered, switch off at the mains socket and remove the plug from the supply.

Installation

1. All Techne units are supplied with a power cable. This may be integral or plug-in.
2. Before connecting the mains supply, check the voltage against the rating plate. Connect the mains cable to a suitable plug according to the table below. **Note that the unit must be earthed to ensure proper electrical safety.**

Connections	220/240V	110/120V
Live	Brown	Black
Neutral	Blue	White
Earth	Green/yellow	Green

The rating plate is on the rear of the unit.

3. Plug the mains cable into the socket on the rear of the unit.
4. Place the unit on a suitable bench or flat workspace, or in a fume cupboard if required, ensuring that the air inlet vents on the underside are free from obstruction.
5. Symbols on or near the power switch of the unit have the following meanings:

I	: mains switch On
O	: mains switch Off

After use

When you have finished heating samples, remember that parts of the unit – the tubes, blocks and associated accessories – may be very hot. Take the precautions listed earlier.

Guarantee

The unit is guaranteed against any defect in material or workmanship for the period specified on the enclosed guarantee card. This period is from the date of purchase, and within this period all defective parts will be replaced free of charge provided that the defect is not the result of misuse, accident or negligence. Servicing under this guarantee should be obtained from the supplier.

Notwithstanding the description and specification(s) of the units contained in the Operator's Manual, Techne hereby reserves the right to make such changes as it sees fit to the units or to any component of the units.

This Manual has been prepared solely for the convenience of Techne customers and nothing in this Instruction Book shall be taken as a warranty, condition or representation concerning the description, merchantability, fitness for purpose or otherwise of the units or components.

User maintenance

NOTE THAT THIS EQUIPMENT SHOULD ONLY BE DISMANTLED BY PROPERLY TRAINED PERSONNEL. REMOVING THE SIDE, FRONT OR REAR PANELS EXPOSES POTENTIALLY LETHAL MAINS VOLTAGES.

THERE ARE NO USER MAINTAINABLE PARTS WITHIN THE EQUIPMENT.

In the unlikely event that you experience any problems with your unit which cannot easily be remedied, you should contact your supplier and return the unit if necessary. Please include any details of the fault observed and remember to return the unit in its original packing. Techne accept no responsibility for damage to units which are not properly packed for shipping: if in doubt, contact your supplier. See the De-contamination Certificate supplied with your unit.

1. Cleaning

Before cleaning your unit ALWAYS disconnect from the power supply and allow to cool below 50° C.

Your unit can be cleaned by wiping with a damp soapy cloth. Care should be exercised to prevent water from running inside the unit. Do not use abrasive cleaners.

2. Fuses

Your unit is protected by one or two fuses. These should only be changed by suitably qualified personnel.

If the fuses blow persistently, a serious fault is indicated and you may need to return the unit to your supplier for repair.

Contact Information

For technical, sales or servicing information, contact your local Techne dealer or,

Barloworld Scientific Ltd
Beacon Road, Stone
Staffordshire
ST15 0SA, United Kingdom
Telephone: +44(0)1785 812121
Fax: +44(0)1785 813748
e-mail: equipment@barloworld-scientific.com

or,

Techne Inc, 3 Terri Lane,
Suite 10, Burlington,
New Jersey 08016, USA.
Telephone: 609-589-2560
Toll free: 800-225-9243 ext 306
Fax: 609-589-2571
e-mail: labproducts@techneusa.com
Web site: www.techneusa.com

Introduction

Veillez lire attentivement toutes les instructions de ce document avant d'utiliser l'appareil.

Avertissement



DANGER DE TEMPERATURES ELEVEES : les opérateurs peuvent subir de graves brûlures et les matériaux combustibles risquent de prendre feu.

Techne a apporté un soin tout particulier à la conception de ces appareils de façon à assurer une protection maximale des opérateurs, mais il est recommandé aux utilisateurs de porter une attention spéciale aux points suivants:

- **PROCEDER AVEC SOIN ET PORTER DES GANTS POUR SE PROTEGER LES MAINS.**
- **NE PAS** poser d'objets chauds sur ou près de matériaux combustibles.
- **NE PAS** utiliser l'appareil à proximité de liquides ou de gaz inflammables.
- **NE PAS** verser de liquide directement dans l'appareil.
- **FAIRE TOUJOURS PREUVE DE BON SENS.**

Sécurité de l'opérateur

Tous les utilisateurs de produits Techne doivent avoir pris connaissance des manuels et instructions nécessaires à la garantie de leur sécurité.

Important : cet appareil doit impérativement être manipulé par un personnel qualifié et utilisé selon les instructions données dans ce document, en accord avec les normes et procédures de sécurité générales. Dans le cas où cet appareil ne serait pas utilisé selon les consignes précisées par Techne, la protection pour l'utilisateur ne serait alors plus garantie.

Tous les appareils Techne sont conçus pour répondre aux normes de sécurité internationales et sont dotés d'un coupe-circuit en cas d'excès de température. Sur certains modèles, ce coupe-circuit est réglable pour s'adapter à l'application désirée. Sur d'autres modèles, il est pré-réglée en usine pour assurer la protection de l'appareil.

Dans le cas d'un problème de sécurité, coupez l'alimentation électrique au niveau de la prise murale et enlevez la prise connectée à l'appareil.

Installation

1. Tous les appareils Techne sont livrés avec un câble d'alimentation qui peut être intégré à l'appareil ou à raccorder.
2. Avant de brancher l'appareil, vérifiez la tension requise indiquée sur la plaque d'identification. Raccordez le câble électrique à la prise appropriée en vous reportant au tableau ci-dessous. **Il est important que l'appareil soit relié à la terre pour assurer la protection électrique requise.**

Connexions	220/240 V	110/120 V
Phase	Marron	Noir
Neutre	Blue	Blanc
Terre	Vert/juane	Vert

La plaque d'identification se trouve à l'arrière de l'appareil.

3. Raccordez le câble d'alimentation à la prise située à l'arrière de l'appareil.
4. Placez l'appareil sur un plan de travail ou surface plane, ou le cas échéant, dans une hotte d'aspiration, en s'assurant que les trous d'aération situés sous l'appareil ne sont pas obstrués.
5. Les symboles situés sur ou à côté de l'interrupteur de l'appareil ont la signification suivante :
 - O** : arrêt
 - I** : marche

Après utilisation

Lorsque vous avez fini de chauffer les échantillons, n'oubliez pas que certaines parties de l'appareil - les éprouvettes, leurs supports et autres accessoires - risquent d'être très chaudes. Il est donc recommandé de toujours prendre les précautions citées plus haut.

Garantie

L'appareil est garanti contre tout défaut ou vice de fabrication pour la durée figurant sur la carte de garantie, à compter de la date d'achat de l'appareil. Au cours de cette période, toutes les pièces défectueuses seront remplacées gratuitement, dans la mesure où la défaillance n'est pas due à une mauvaise utilisation, un accident ou une négligence. Toute réparation sous garantie sera effectuée par le fournisseur.

Malgré la description et les spécifications de l'appareil données dans le manuel de l'utilisateur, Techne se réserve le droit d'effectuer les changements nécessaires à l'appareil ou à tout élément qui entre dans sa composition. Ce manuel a été exclusivement rédigé à l'attention des clients de Techne, et aucun élément de ce guide d'instructions ne peut être utilisé comme garantie, condition ou représentation concernant la description, commercialisation, adaptation aux conditions d'utilisation ou autre des appareils ou de leurs composants.

Entretien utilisateur

IMPORTANT : CET APPAREIL NE PEUT ETRE DEMONTE QUE PAR DU PERSONNEL QUALIFIE.

LORSQUE LES PANNEAUX AVANT, ARRIERE ET LATERAUX SONT DEMONTES, L'OPERATEUR EST EXPOSE A DES TENSIONS QUI PEUVENT ETRE MORTELLES.

CET APPAREIL NE CONTIENT AUCUN ELEMENT QUI DEMANDE UN ENTRETIEN DE LA PART DE L'UTILISATEUR.

Dans le cas peu probable où votre appareil présente un défaut de fonctionnement auquel il est difficile de remédier, il est alors préférable de contacter votre fournisseur et, le cas échéant, de renvoyer le matériel. Veuillez inclure une description détaillée du problème constaté et retourner l'appareil dans son emballage d'origine. Techne ne sera pas tenu responsable des dommages subis par tout appareil dont l'emballage est inadéquat pour le transport. Pour plus de sûreté, contactez votre fournisseur. Voir le certificat de décontamination livré avec le produit.

1. Nettoyage

Avant de nettoyer l'appareil, assurez-vous **TOUJOURS** que le câble d'alimentation est déconnecté et laissez la température redescendre en dessous de 50 °C.

Utilisez un chiffon imprégné d'eau savonneuse pour nettoyer l'appareil. Veillez à ne pas introduire d'eau dans l'appareil. N'utilisez pas de produits abrasifs.

2. Fusibles

La protection de l'appareil est assurée par un ou deux fusibles dont le remplacement ne peut être effectué que par un personnel qualifié.

Si les fusibles sautent sans arrêt, il s'agit d'un problème sérieux. Nous vous conseillons dans ce cas de prendre contact avec votre fournisseur pour réparation.

Einleitung

Bitte lesen Sie diese Bedienungsanleitung komplett bevor Sie dieses Gerät benutzen.

Warnung



HOHE TEMPERATUREN SIND GEFÄHRLICH: sie können dem Bediener ernsthafte Verletzungen zufügen und brennbare Materialien können sich leicht entzünden.

Techne hat bei der Konstruktion dieses Gerätes sehr darauf geachtet, daß der Bediener vor Gefahren geschützt ist. Dennoch sollten Sie auf die folgenden Punkte achten:

- SEIEN SIE VORSICHTIG UND TRAGEN SIE SCHUTZHANDSCHUHE
- Legen Sie heiße Gegenstände NICHT auf oder in die Nähe von leicht brennbaren Materialien; vermeiden Sie Arbeiten in der Nähe von leicht entzündbaren Flüssigkeiten oder Gasen.
- Bringen sie KEINE Flüssigkeiten direkt in Ihr Gerät.
- Benutzen Sie immer den normalen Menschenverstand

Sicherheit des Anwenders

Alle Benutzer von Techne Geräten müssen Zugang zu der entsprechenden Literatur haben, um ihre Sicherheit zu gewährleisten.

Es ist wichtig, daß diese Geräte nur von entsprechend geschultem Personal betrieben werden, das die in dieser Gebrauchsanweisung enthaltenen Maßnahmen und allgemeine Sicherheitsbestimmungen und -vorkehrungen beachtet. Wenn das Gerät anders eingesetzt wird als vom Hersteller empfohlen, kann dies die persönliche Sicherheit des Anwenders beeinträchtigen. Die Geräte von Techne entsprechen den internationalen Sicherheitsbestimmungen und sind mit einem automatischen Übertemperaturabschalter ausgestattet. Bei einigen Modellen ist der Übertemperaturabschalter verstellbar und sollte je nach Anwendung entsprechend eingestellt werden. Bei allen anderen Modellen ist der Temperaturschutz voreingestellt um Schäden am Gerät zu vermeiden. Wenn ein Sicherheitsproblem auftreten sollte, muß das Gerät ausgeschaltet und vom Stromnetz getrennt werden.

Installation

1. Alle Techne Geräte werden mit einem Stromanschlußkabel geliefert. Dieses ist entweder fest mit dem Gerät verbunden oder zum Einstecken.
2. Vergleichen Sie, ob die Spannung Ihrer Stromversorgung mit den Angaben auf dem Typenschild des Gerätes übereinstimmen. Verbinden Sie das Stromanschlußkabel mit einer geeigneten Stromversorgung gemäß der nächstehenden Tabelle. **Achtung:** Das Gerät muß geerdet sein, um die elektrische Sicherheit zu gewährleisten!

<i>Verbindungen</i>	<i>220/240V</i>	<i>110/120V</i>
Stromführend	Braun	Schwarz
Neutral	Blau	Weiß
Erde	Grün/Gelb	Grün

Das Typenschild befindet sich hinten am Gerät.

3. Stecken Sie das Stromkabel in die vorgesehene Buchse hinten am Gerät.
4. Stellen Sie das Gerät auf eine ebene Arbeitsfläche bzw. (falls erforderlich) unter einen Laborabzug. Beachten Sie, daß die Entlüftungsrippen an der Geräteunterseite immer frei zugänglich sind.
5. Die Symbole auf oder neben dem EIN/AUS-Schalter an der Geräterückseite bedeuten:

I : An
O : Aus

Nach dem Gebrauch

Vergessen Sie nicht, daß Teile des Gerätes (die Gefäße, die Blöcke und andere Zubehörteile) nach dem Erhitzen von Proben noch sehr heiß sein können. Bitte beachten Sie die oben genannten Vorsichtsmaßnahmen.

Garantie

Die Garantiedauer des Gerätes ist auf der beiliegenden Garantiekarte angegeben und schließt Fehler im Material oder der Verarbeitung ein. Die Garantiedauer beginnt am Tag des Einkaufs. Sämtliche defekte Teile werden innerhalb dieses Zeitraumes kostenlos ersetzt unter der Voraussetzung, daß dem Defekt keine unsachgemäße Handhabung, Fahrlässigkeit oder ein Unfall zugrundeliegt. Der unter diese Garantie fallende Service wird vom Lieferanten geleistet.

Ungeachtet der in dieser Gebrauchsanweisung enthaltenen Beschreibungen und Spezifikationen, behält sich Techne hiermit das Recht vor, Änderungen an den Geräten bzw. an einzelnen Geräteteilen durchzuführen. Diese Gebrauchsanweisung wurde ausschließlich dazu erstellt, um Kunden die Handhabung der Techne-Geräte zu erleichtern. Nichts in dieser Gebrauchsanweisung darf als Garantie, Bedingung oder Voraussetzung verstanden werden, sei es die Beschreibung, Marktgängigkeit, Zweckdienlichkeit oder sonstiges bezüglich der Geräte oder deren Bestandteile.

Wartung durch den Bediener

BEACHTEN SIE, DASS DIESES GERÄT NUR VON TECHNISCHEN FACHKRÄFTEN GEÖFFNET UND DEMONTIERT WERDEN DARF.

DURCH ENTFERNEN DES GEHÄUSES ODER GEHÄUSETEILEN SIND BAUTEILE MIT LEBENSGEFÄHRLICHEN SPANNUNGEN FREI ZUGÄNGLICH. IM INNERN DES GERÄTES BEFINDEN SICH KEINE TEILE, DIE VOM ANWENDER GEWARTET WERDEN MÜSSEN.

Falls Ihr Gerät nicht ordnungsgemäß arbeitet, wenden Sie sich an Ihren Lieferanten oder senden Sie das Gerät wenn nötig zurück. Fügen Sie eine genaue Beschreibung des Defektes bei. Verpacken Sie das Gerät möglichst im Originalkarton. Bitte beachten Sie, daß Techne keine Haftung bei Transportschäden aufgrund unzureichender Verpackung übernehmen. Setzen Sie sich im Zweifelsfall mit Ihrem Lieferanten in Verbindung. Bitte beachten Sie die Entgiftungsbescheinigung, die Sie mit dem Gerät erhalten haben.

1. Reinigen

Bevor Sie Ihr Gerät reinigen, sollten Sie

- zuerst den Netzstecker ziehen
- das Gerät unter 50°C abkühlen lassen.

Ein feuchtes Tuch mit Seifenlösung reinigt Ihr Gerät am besten. Achten Sie darauf, daß kein Wasser in das Gerät gelangt. Verwenden Sie keine Scheuermittel.

2. Sicherungen

Die Stromzuleitung ist durch ein oder zwei Sicherungen geschützt. Diese sollten nur durch qualifiziertes Fachpersonal ausgetauscht werden. Wenn die Sicherung wiederholt durchbrennt, liegt ein größerer Defekt vor. Das Gerät muß zur Reparatur an Ihren Lieferanten eingesandt werden.

Introducción

Le rogamos lea cuidadosamente la información contenida en este folleto antes de manipular el aparato.

Aviso



LAS TEMPERATURAS ELEVADAS SON PELIGROSAS: pueden causarle graves quemaduras y provocar fuego en materiales combustibles.

Techne ha puesto gran cuidado en el diseño de estos aparatos para proteger al usuario de cualquier peligro; aún así se deberá prestar atención a los siguientes puntos:

- EXTREME LAS PRECAUCIONES Y UTILICE GUANTES PARA PROTEGERSE LAS MANOS;
- NO coloque objetos calientes encima o cerca de objetos combustibles;
- NO maneje el aparato cerca de líquidos inflamables o gases;
- NO introduzca ningún líquido directamente en el aparato;
- UTILICE EL SENTIDO COMUN en todo momento.

Seguridad del usuario

Todos los usuarios de equipos Techne deben disponer de la información necesaria para asegurar su seguridad. De acuerdo con las instrucciones contenidas en este manual y con las normas y procedimientos generales de seguridad, es muy importante que sólo personal debidamente capacitado opere estos aparatos. De no ser así, la protección que el equipo le proporciona al usuario puede verse reducida.

Todos los equipos Techne han sido diseñados para cumplir con los requisitos internacionales de seguridad y traen incorporados un sistema de desconexión en caso de sobretemperatura. En algunos modelos el sistema de desconexión es variable, lo que le permite elegir la temperatura según sus necesidades. En otros, el sistema de desconexión viene ya ajustado para evitar daños en el equipo.

En caso de que surgiera un problema de seguridad, desconecte el equipo de la red.

Instalación

1. Todos los aparatos Techne se suministran con un cable de alimentación. Puede ser fijo o independiente del aparato.
2. Antes de conectarlo, compruebe que el voltaje corresponde al de la placa indicadora. Conecte el cable de alimentación a un enchufe adecuado según la tabla expuesta a continuación. El equipo debe estar conectado a tierra para garantizar la seguridad eléctrica.

<i>Conexiones</i>	220/240V	110/120V
Línea	Marrón	Negro
Neutro	Azul	Blanco
Tierra	Verde/amarillo	Verde

La placa indicadora está situada en la parte posterior del equipo.
3. Conecte el cable a la toma de tensión en la parte posterior del equipo.
4. Sitúe el aparato en un lugar apropiado tal como una superficie de trabajo plana, o si fuera necesario incluso en una campana con extractor de humos, asegurándose de que las entradas de aire en la parte inferior no queden obstruidas.
5. Los símbolos que se encuentran en o cerca del interruptor de alimentación tienen los siguientes significados:

I	: Interruptor principal encendido
O	: Interruptor principal apagado

Después de su uso

Cuando haya finalizado el calentamiento de muestras, recuerde que las piezas del equipo, tales como tubos, bloques y demás accesorios, pueden estar muy calientes. Tome las precauciones mencionadas anteriormente.

Garantía

Este aparato está garantizado contra cualquier defecto material o de fabricación durante el periodo especificado en la tarjeta de garantía adjunta. Este plazo inicia a partir de la fecha de compra, y dentro de este periodo todas las piezas defectuosas serán reemplazadas gratuitamente siempre que el defecto no sea resultado de un uso incorrecto, accidente o negligencia. Mientras se encuentre bajo garantía las revisiones las debe llevar a cabo el proveedor. A pesar de la descripción y las especificaciones de los aparatos contenidas en el Manual del Usuario, Techne se reserva por medio de este documento el derecho a efectuar los cambios que estime oportunos tanto en los aparatos como en cualquier componente de los mismos. Este manual ha sido preparado exclusivamente para los clientes de Techne y nada de lo especificado en este folleto de instrucciones se tomará como una garantía, condición o aseveración de la descripción, comerciabilidad o adecuación para cualquier fin específico de los aparatos o sus componentes.

Mantenimiento

ESTE APARATO DEBE SER DESMONTADO SOLO Y EXCLUSIVAMENTE POR PERSONAL DEBIDAMENTE CAPACITADO.
EL RETIRAR LOS PANELES LATERALES, FRONTALES O TRASEROS SUPONE DEJAR AL DESCUBIERTO TENSIONE DE LA RED PELIGROSA.
EL EQUIPO NO CONSTA DE NINGUNA PIEZA DE CUYO MANTENIMIENTO SE PUEDA ENCARGAR EL USUARIO.
En el caso improbable de que experimentara algún problema con su aparato que no pudiera resolver con facilidad, debería ponerse en contacto con su proveedor y devolverlo si fuera necesario. Indique de forma detallada todos los defectos que haya notado y devuelva el equipo en su embalaje original. Techne no aceptará responsabilidad alguna por daños causados en equipos que no estuvieran debidamente embalados para su envío; si tuviera alguna duda, póngase en contacto con su proveedor. Sírvase consultar el Certificado de Descontaminación suministrado con su aparato.

1. Limpieza

Antes de limpiar su aparato, desconéctelo SIEMPRE de la fuente de alimentación y permita que se enfríe por debajo de los 50°C.

Este aparato se puede limpiar pasándole un paño húmedo enjabonado. Hágalo con cuidado para evitar que caiga agua dentro del mismo. No utilice limpiadores abrasivos.

2. Fusibles

Su aparato está protegido por uno o dos fusibles. Sólo deben cambiarlos personal debidamente capacitado. Si los fusibles se fundieran repetidamente, esto indicaría una avería grave y puede que tuviera que devolverle el aparato a su proveedor para su reparación.

INTRODUCTION

Read the whole of this book before commencing work with the unit.

OPERATOR SAFETY

It is important that only suitably instructed personnel operate this equipment. It must also be used in accordance with the instructions contained in this manual and with proper safety standards and procedures.

It is imperative that all personnel who may come into contact with our equipment have available such of our literature as they require to ensure their safety.

Contact Information

For technical, sales or servicing information, contact your local Techne dealer or,
Techne, Duxford,

Cambridge, CB2 4PZ, United Kingdom.

Telephone: +44(0)1223 832401

Fax: +44(0)1223 836838

Service: +44(0)1223 836950 Out of office hours

e-mail: sales@techne.com

Web site: www.techne.com

or,

Techne Inc, 3 Terri Lane,

Suite 10, Burlington,

New Jersey 08016, USA.

Telephone: 609-589-2560

Toll free: 800-225-9243 ext 306

Fax: 609-589-2571

e-mail: labproducts@techneusa.com

Web site: www.techneusa.com

GENERAL DESCRIPTION

The fluidised bath employs the principle of fluidisation of a mass of finely divided inert particles by means of an upward stream of gas. A state of fluidisation is achieved when the individual particles become microscopically separated from each other by the moving gas. This "fluidised bed" of particles has unusual properties which differ markedly from either those of the gas or of the solid particles. Instead, the fluidised bed behaves remarkably like a liquid, exhibiting characteristics which are generally attributable to a liquid state. For example, the fluidised bed can be agitated and bubbled; it always seeks a common level; materials of less density will float while those with densities greater than the equivalent fluidised bed density will sink; and, most important, the heat transfer characteristics between the fluidised bed and a solid interface can have an efficiency approaching that of an agitated liquid.

In addition, the fluidised solid phase has a most unusual physical behaviour, in that its basic characteristic change only slightly over very large temperature ranges; it has no melting point and no boiling point. The lowest temperature available is the liquefaction point of the gas used for fluidisation, while the high temperature level is the usable temperature of the inert solids. Various metal oxides with allowable temperatures of over 1700°C (3092°F) are readily available. The metal oxide beds commonly used, (eg aluminium oxide) are non-flammable, non-explosive and non-toxic.

The most commonly used fluidising gas is ordinary compressed air obtained from a blower or compressor. For situations where a non-oxidising atmosphere is required, nitrogen can be utilised and if a reducing atmosphere is required, cracked gas can be employed with a silicon carbide bed.

The unique characteristic of gas-fluidised particles is the relatively high rate of heat transfer which yields highly isothermal conditions, as well as excellent heat transfer to solid surfaces. This characteristic is due to the turbulent motion and rapid circulation rate of the solid particles in conjunction with the extremely high solid-gas interface area. Therefore, despite the fact that gas-solid interfaces normally yield low heat transfer coefficients and the solids normally used have low thermal conductivities, the overall heat transfer characteristics of fluidised particles approach those of a liquid.

The combination of excellent heat transfer characteristics and high capacity are ideal for attaining rapid stabilisation at an isothermal condition.

The Techne BFS high temperature fluidised calibration bath is designed to have particularly good fluidisation characteristics, combined with excellent temperature control over the temperature range 200°C to 1100°C.

The fluidised bath consists of a circular retort manufactured from a high nickel / chromium alloy in the base of which is positioned an air distribution system. The air distribution system is arranged so that the flow pattern within the fluidised bed may be influenced by the operator to ensure good temperature distribution.

The fluidised bed consists of two different layers of inert particles. The lower layer of zirconium oxide acts as a diffuser while also acting as a thermal barrier between the heated upper layer and the air distribution system. The upper layer of aluminium oxide is fluidised by the upward stream of fluidising air which is passed through the zirconium oxide.

The fluidised bath is mounted within an electrically heated radiant furnace, the temperature of which is monitored by a thermocouple sensor whose tip is housed in a pocket on the outside wall of the fluidised bath. The fluidised bath is enclosed within the furnace by a hinged insulated lid which has a small removable ceramic bung. This bung may be removed to gain access to the fluidised bath or alternatively the bung may be machined and items being calibrated passed through holes in the bung. When correctly operated the fluidised bed generates a small amount of harmless dust. The dust is removed from the surface of the bed by an integral dust extraction system. The extraction system consists of a pitot device which is driven by a small quantity of compressed air. This system entrains any fine dust particles and passes them through an exhaust tube to a point where they may be collected, or dispersed to atmosphere.

The temperature of the fluidised bath is indicated and controlled by a remote three term proportional temperature controller.

The fluidising air flow is controlled by a remote unit which contains flowmeters and air adjustment valves for each of the two air distribution chambers. It also contains an adjustment valve for controlling the dust extraction system.

It is important to ensure that the air supply to the fluidised bath is clean, dry, free from oil, and at a constant pressure. Techne are able to supply a suitable air filter and pressure regulator assembly for installations where the fluidising air is obtained from the compressed air line. Techne are alternatively able to offer a suitable free standing air compressor complete with the necessary filtration system for installations where a compressed air supply is not available.

Avoid siting the BFS in a laboratory environment which contains instruments that are sensitive to dust. Although the fluidised bath has its own dust extraction system, a small amount of fine dust may still be emitted during normal operation.

If used for processing items which may emit toxic fumes, it is essential that an adequate fume extraction system is installed.

Fluidising medium

The aluminium oxide fluidising medium supplied with BFS baths is of a special grade known as tubular alumina, and will fluidise satisfactorily up to the maximum operating temperature of the bath (1100°C). Note that other grades of aluminium oxide do not have this capability.

TECHNICAL SPECIFICATION

Operating temperature	200°C to 1100°C
Temperature stability	±0.5°C at all temperatures
Temperature uniformity (at the limits of the working volume)	
At 350°C	±0.5°C]
At 600°C	±2.0°C] All better than
At 1000°C	±3.5°C] ±0.35%
Nominal heater power	6kW
Heat up time:	20°C to 1000°C 4 hours 10 minutes
Cool down time:	1100°C to 200°C 11 hours
Electrical supply	220/240V 1PH 50/60Hz
or	208V 1PH 50/60 Hz
Air supply pressure	0.48 bar (7 lb/in ²)
Maximum air consumption	85 litre/min (3 ft ³ /min)
Fluidising medium	
Aluminium Oxide (Part No F0937)	7.3 kg
Zirconium Oxide (Part No F0854)	17 kg
Overall size of fluidised bath	
Length	686 mm
Width	686 mm
Height	876mm
Overall size of remote control unit	
Length	460mm
Width	310mm
Height	355mm
Length of interconnecting lead	2 metre
Internal dimensions	
Diameter (90mm x 90mm access)	218mm
Depth (to top of zirconium)	380mm
Usable depth below surface of fluidised medium (to top of zirconium)	260mm
Working volume:	
For quoted uniformity and access through lid:	82.5mm square x 203mm deep
Maximum usable dimensions:	203mm dia x 203mm deep
Maximum Load	
Volume	2.2 litre
Cross sectional area	1080mm ²
Total net shipping weight	340kg/386kg

INSTALLATION

It is recommended that the BFS is not sited in a laboratory environment which contains instruments that are sensitive to dust. Mount the BFS on a solid, level floor. The control unit may be mounted on an adjacent bench or shelf.

Checking the retort

Remove the small bung from the centre of the lid and raise the lid to inspect the furnace. Remove any packing material that may be present within the furnace. Ensure that the circular retort is central within the furnace. If the retort has moved during transit, realign by gently pushing the top of the retort until it is central; finally, push the retort firmly down into its seating.

Filling with sands

Fill the retort with the zirconium oxide (brown in colour) until the raised section in the centre of the base is covered by approximately 30mm of powder. Level the surface of the zirconium oxide before adding the aluminium oxide (white in colour). The aluminium oxide should be added until the retort is full to within 150mm of the top rim.

Connecting the furnace and control unit

The furnace and remote control unit are supplied as separate items to ease shipment. Before connecting to an electrical supply the control unit must be connected to the furnace. Remove the projecting heater terminal cover mounted on the right hand side wall of the furnace and connect the load leads from the control unit to the terminals below the heater connections. Note that the control unit has two sets of flying leads, one for the load, the other for the mains supply; the mains lead is identified by a label on the rear of the control unit.

Connections to the terminals should be made as follows:

Brown or Red to Brown or Red heater connections

Blue or Black to Blue or Black heater connections

Green/Yellow to Earth point.

Replace the heater terminal cover.

Connections to the Power (Mains)

Connect the mains lead from the control unit to a suitable electrical supply. See instrument rating plate for details of the electrical supply required.

Connections are as follows:

Brown or Red to Live

Blue or Black to Neutral

Green/Yellow to Earth.

Fitting the Thermocouple

The control thermocouple must be positioned in the hole provided at the rear of the furnace. Remove the small cover plate from the rear of the furnace and fit the thermocouple through the central hole using the nuts provided with the thermocouple.

To ensure that the retort is earthed it is essential that the two lock nuts supplied with the thermocouple are tightened onto the port cover

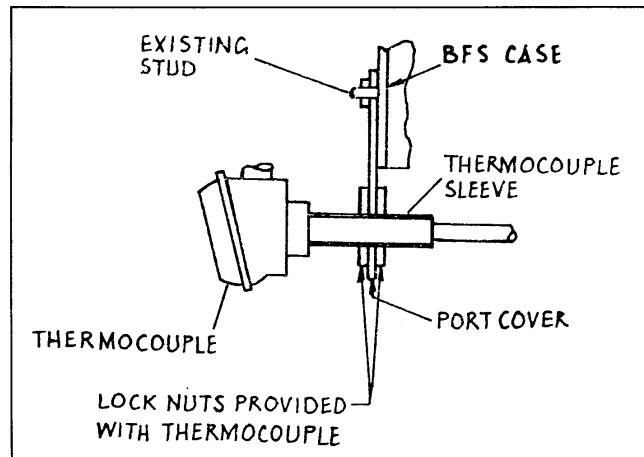

As the thermocouple is inserted into the BFS, the tip of the sensor must be guided into the thermal well on the side of the retort. Secure the thermocouple in position by re-fixing the cover plate to the wall of the furnace.

Compressed air

A compressed air supply must be connected to the air input port at the rear of the air control unit. The compressed air supply must be clean, dry, free from oil, and at a constant pressure approximately 0.48 bar (7 lb/in²).

Techne are able to supply a suitable air filter and pressure regulator assembly for installations where the fluidising air is obtained from a compressed air line. Alternatively, Techne can supply a free standing air compressor complete with the necessary filtration system for installations where a compressed air supply is not available (for details see Accessories).

It is important to ensure that the air supply used is clean and at a constant pressure; use of a dirty air supply will result in the porous plate at the base of the fluidised bed becoming contaminated, causing uneven fluidisation with deterioration of temperature control, stability and uniformity. Variations in the air supply pressure can result in over-fluidisation which mixes the two layers of particles within the bed. Once mixed, the zirconium and aluminium oxide cannot readily be separated, and will probably have to be replaced.

The air connections at the rear of the control unit are suitable for the following types of pipework:

- 8mm (5/16 inch) external diameter copper pipe,
- or 1/4 inch BSP female connectors,
- or 9.5mm (3/8 inch) internal diameter flexible hose, when used in conjunction with suitable hose nozzles such as Techne Part No 6001946 (see Accessories).

Pipework less than 6mm internal diameter should not be used as this will impair the fluidisation within the bath.

Air connections

Connect the 'outer chamber' input port at the rear of the furnace, using pipework as above.

Similarly connect the 'inner chamber' output port to the 'inner chamber' input port.

Exhaust

Connect the 'exhaust' output port at the rear of the control unit to the 'exhaust' input port at the rear of the furnace.

The dust extraction tube at the rear of the furnace must be connected to a dust collector. It is important to note that during operation the exhaust pipework will become hot due to the high temperature of the air within the furnace. It is therefore important to ensure that metal pipework is used for the extraction system.

The exhaust tube is threaded 1 inch BSP.

The extraction pipework should be as short as possible to ensure that exhausted dust does not build up within the system causing a blockage. Ideally the extraction system should carry the dust laden air away from the working environment; however, where this is not practical, it is permissible to trap the dust in a container having a small amount of water in its base. It is important to ensure that the container is metallic because of the high temperature of the exhaust. Arrange the extraction system so that the exhaust is directed on to the surface of the water in the container, but do not immerse the extraction system into the water as this will cause back pressure and impair the efficiency of the extraction system.

If the fluidised bath is to be used for processing items which may emit toxic fumes, it is essential that an adequate fume extraction system is installed.

OPERATION

The BFS high temperature calibration fluidised bath is capable of precise performance, but for reliable and consistent results it must be operated by personnel conversant with its operation.

Temperature stability within the fluidised bed is attained when the heat input exactly equals the heat losses from the bed; the heat input from the radiant furnace is controlled by the temperature controller, while the heat losses from the bed are due to:

- 1 Heating the fluidising air;
- 2 Radiation from the top of the bed;
- 3 Conduction along the stems of objects immersed in the bed;
- 4 Heating the mass of cold objects immersed in the bed.

Changing any of these parameters will affect the temperature stability within the fluidised bed. The temperature of the bed will recover under the influence of the temperature controller; however, after any parameter is changed, there is a delay before the temperature of the bed re-stabilises.

The temperature uniformity within the fluidised bed is effected by the degree of fluidisation. As the temperature of the fluidised bed increases the fluidising air is heated and expands, which increases the degree of fluidisation while the air input remains constant. Therefore the amount of air required to achieve ideal fluidisation varies with the bed temperature. The fluidising air flow rate must therefore be adjusted as the bed heats up. If the air flow is too small the bed will be underfluidised and large temperature gradients will occur within the bed. If the air flow is too large the bed will be overfluidised; this will result in the formation of excessive dust above the bed and may cause the two different materials within the bed to mix. If the zirconium and aluminium oxides mix, the specified temperature performance of the bath will not be achievable until the bed materials are replaced.

To set the operating temperatures when supplied with a Eurotherm 815S Controller.

When the mains switch is set to the ON position the fluorescent indicator panel will display the measured value of temperature in digital form.

For the operation of the controller see the Eurotherm manual.

The following control parameters have been factory pre-set:

Pr	8000
Pb	1.5
ti	350
td	60.0
cbl	20
cbh	20
HI	100
Hc	25
Sbr	0

To set the operating temperatures when supplied with a Eurotherm 2204e Controller.

When the mains switch is set to the ON position the fluorescent indicator panel will display the measured value of temperature in digital form.

For the operation of the controller see the Eurotherm manual.

In order to preserve the insulation bricks during transportation the unit is only tested up to 500°C. We suggest that you “autotune” the controller (see the Eurotherm Manual) at the set temperature you require.

To set the correct level of fluidisation within the bath:

Ensure that the valves at the base of the “Fluidisation outer chamber” and “Fluidisation inner chamber” flowmeters are in the closed position - Turned fully clockwise.

Ensure that the “Exhaust control” valve is in the closed position - turned fully clockwise.

If the fluidising air is being supplied from a compressed air line, ensure that the pressure regulator, which must be fitted between the air line and the fluidised bath, is in the off position before connecting to the air line.

If the fluidising air is being supplied by a Techne air compressor a pressure regulator is not required.

Adjust the air pressure regulator until a pressure of 0.48 bar (7 lb/in²) is supplied to the control unit, or switch on the Techne air compressor, as may be the case.

Carefully open the “Exhaust control” valve until the furnace is under a slight negative pressure. This may be checked by removing the lid access bung and placing a sheet of paper over the access hole. When the exhaust control valve is correctly set the paper will be attracted to the surface of the lid. It is not necessary to have excessive dust extraction. The rate of extraction may be further adjusted during operation to ensure that any fine particles emitted from the surface of the fluidised bath are entrained by the extraction system.

To minimise any risk of the furnace being damaged in transit, the furnace is not fully dried prior to despatch. Therefore prior to use the furnace should be dried in accordance with the following:

- a Fluidise the bath in accordance with the following table and switch on the temperature control system. The clear neon indicator illuminates when the control system is switched on. (For units prior to Serial No. /16 the amber neon indicates the heater state). Heat the bath to a temperature of 90°C and maintain at this level for 4 hours.
- b Increase the furnace temperature to 200°C and maintain at this level for a period of approximately 18 hours.
- c Increase the furnace temperature to 600°C and maintain at this level for a period of approximately 9 hours.
- d Continue to increase the furnace temperature in 50°C increments, dwelling at each temperature for approximately 2 hours, until the maximum operating temperature of 1100°C has been attained.

To stimulate the removal of water vapour from the furnace, the access bung in the furnace lid should be removed during the drying period. It is possible that, during this period, the unit will smell of ammonia or hydrogen sulphide. Any such emission will be temporary and will not occur during subsequent operation.

Carefully open both of the fluidisation control valves until the indicated flow corresponds with the following table.

Actual Bath Temperature °C	Inner Chamber Litre/min	Outer Chamber Litre/min
50	9.0	35.0
100	8.5	32.0
150	8.0	29.0
200	7.0	25.0
250	6.5	24.0
300	6.0	21.0
400	5.5	18.0
500	5.0	16.0
600	4.5	14.0
700	4.0	13.0
800	3.5	12.0
900	3.0	11.0
1000	3.0	10.0
1100	2.5	9.5

It will be noted that it is necessary to adjust the fluidising air flow rates as the temperature of the fluidised bath increases.

The air flow rates quoted are approximate and at any given temperature the nature of the load can influence the air consumption required to achieve optimum temperature uniformity and stability.

When correctly fluidised, the surface of the bath has an appearance like swirling cream, with slight bubbling. The material rises in the centre of the bath and moves smoothly towards the walls.

The temperature of the external surfaces of the furnace will be high during the drying period. This is due to the poor insulating properties of the refractory lining material in the undried state.

When the furnace is completely dried the insulation properties of the refractory lining material increases, and the temperature of the external surfaces will be reduced. **However, due to the extremely high temperatures within the furnace, the external walls, and in particular the removable access bung, should always be treated with care as they may be hot. We recommend that protective clothing - gloves, aprons and visors - be worn when working with this unit.**

During normal operation the fluidised bath be heated to the required operating temperature and the fluidising air adjusted according to the above table. Once the temperature controller indicates that the set temperature has been achieved, allow the bath time to stabilise prior to calibration work.

Items to be calibrated within the fluidised bath may either be passed directly into the fluidised bath by removing the lid access bung, or alternatively the lid access bung may be machined and the items being calibrated passed through close fitting holes in the bung. Spare lid bungs, Part No 6003867, are available, thus enabling the user to machine a range of bungs to suit various items being calibrated.

Calibration.

- 1 When using the BFS to calibrate thermal sensors such as thermocouples and platinum resistance thermometers, it is important to ensure that the working volume of the bath is thermally stable. Use an independent temperature sensor, such as a reference thermocouple, to check the temperature uniformity and stability, see Specification.
- 2 The temperature stability of the fluidised bath at any operating temperature may be improved by tuning the control parameters of the temperature controller to match the performance of the system under any set conditions. Adjustment details are contained within the manufacturers instruction manual.
- 3 For precise calibration the actual temperature of the fluidised bath should be measured with an independent calibrated reference sensor; the temperature indicated by the temperature controller should only be used as a guide and not as an indication of absolute temperature.
- 4 The number of sensors calibrated in the fluidised bath at any one time should be kept to a minimum so as not to disturb the flow pattern within the bath. Typically up to 10 sensors of approximately $\varnothing 10\text{mm}$ may be calibrated without loss of performance.

Dead Bed Calibration.

- 1 Temperature stability during calibration may be further improved by using a dead bed calibration technique. This technique involves heating the bath to the required calibration point, then allowing the temperature of the bath to stabilise for a period of approximately 20 minutes, dependent upon the actual calibration temperature and the thermal mass of the sensors being calibrated.
- 2 The fluidised bed is collapsed by cutting off the fluidising air and mains power supply to the BFS so that the sensors being calibrated are surrounded by a solid bed of alumina which acts as a thermal insulator. After a period of approximately 2 minutes at set temperature a stability of 0.01°C can be achieved for a further period of approximately 8 minutes, dependent upon heat loss along the stem of the sensors being calibrated.
- 3 At the end of the required period of dead bed it is necessary to reconnect the fluidising air and the power supply to the BFS.

MAINTENANCE.

The fluidising medium is hygroscopic, and will absorb moisture if left in the fluidised bath for long periods without use. To remove this moisture, heat the fluidised bath to a temperature of 90°C and maintain this level for a period of approximately 4 hours. Then increase the temperature to 600°C and maintain this level for a further period of approximately 4 hours to enable chemically bonded water to be liberated.

It is important to ensure that the air supply to the fluidised bath is clean, dry, free from oil, and at a constant pressure. If the fluidising air is supplied from a compressed air line, regularly inspect the air filters and clean or replace the elements as required.

If the fluidising air is supplied from a Techne compressor, regularly inspect and clean the air intake filter.

The fluidising medium will require attention when losses occur due to attrition or spillage. Regularly inspect the level of the fluidising medium within the bath. The nominal depth between the top rim of the inner container and the top of the fluidising medium is 150mm when in the on fluidised state. New fluidising medium, Part No F0937, may only be added when the fluidised bath is cold. The fluidising medium is hygroscopic and will therefore contain moisture when new. After adding new fluidising medium the bath should be heated to a temperature of 90°C and maintained at this level for a period of approximately 4 hours. The temperature should then be increased to 600°C and maintained at this level for a further period of approximately 4 hours to enable chemically bonded water to be liberated.

Regularly inspect the interior of the furnace to ensure that fluidising medium does not settle on the heater elements. Any such material may be removed from the heater elements with a vacuum cleaner when the unit is cold.

FAULT FINDING.

- 1 If the furnace fails to reach its operating temperature or the heat up rate decreases, check the electrical supply and the resistance of the heater elements. Access can be gained to the heater terminals by removing the projecting heater terminal cover on the right hand side wall of the furnace. A total of 8 heater elements are fitted, arranged in two banks of four elements in series.

Heater elements may be replaced by disconnecting the heater terminals, withdrawing the three ceramic rods in three corners of the furnace, and lifting the damaged heater out of the supporting groove. Before replacing any damaged heater elements, ensure that the heater supporting groove is clean and free from swarf.

- 2 If the fluidised bath fails to achieve its specified performance, check that the fluidising air flow rates correspond with the recommended figures and that the compressed air supply to the fluidised bath is set at the correct pressure. If adjustment of the fluidising air flow rates does not improve the performance, allow the bath to cool and inspect the fluidising materials for signs of mixing. The upper layer of aluminium oxide should be white in colour and when fluidised should have the appearance of swirling cream. With the fluidising air flow rate set correctly, carefully insert a probe into the fluidising bath. Move the probe from side to side to determine whether there are areas of the bath which are not fluidised. It should be possible to move the probe through the bath in a similar fashion to moving an object through water. Run the tip of the probe over the surface of the zirconium oxide which is below the fluidised aluminium oxide to check that the surface of the zirconium oxide is flat.

If the aluminium oxide is no longer white, but contains particles of brown zirconium oxide, or there are areas of the bath which do not fluidise, or if the surface of the zirconium oxide is not flat, mixing must be suspected.

Mixing of the two materials is caused by overfluidising the bath; the best solution to the problem is to replace the fluidised bath materials. Where fresh supplies of zirconium and aluminium oxide are not available, it is possible, with care to re-separate the materials. This may be achieved by either:

Carefully vacuuming the white aluminium oxide from the surface of the fluidised bath until only the zirconium oxide is left in the base of the bath, then replacing the aluminium oxide on top of the zirconium oxide.

or

By removing all the bath material and slowly replacing, with the bath just fluidised, allowing time for the materials to separate each time material is added to the bath.

When new fluidising medium is added to the bath it must be remembered that the material is hygroscopic and therefore the material must be dried prior to use at high temperatures. Follow the procedure detailed earlier, i.e. heat to 90°C and maintain at this level for 4 hours, increase the temperature to 600°C and maintain at this level for a further 4 hours before operating at elevated temperatures.

SPARE PARTS

Part No	Description	Qty	Notes
F0854	Zirconium oxide, 17kg Pack	1	
F0937	Tabular alumina, 8kg or 16kg pack	1	
6001195	Mains Switch	1	
6100327	Temperature Controller 810	1	Ser No/16
6102043	Temperature Controller 815S	1	Ser No/17
6104777	Temperature Controller 2204e	1	Ser No/18 on
6003861	Fluidised Bath Inner Container	1	
6003866	Heater Element	1	220/240V
6004533	Heater Element	1	208V
6003867	Replacement Lid Bung	1	
6004257	Outer Zone Flowmeter	1	Prior to Ser No/11
6100303	Outer Zone Flowmeter	1	Ser No/11 on
6004394	Replacement Flowmeter Tube	1	All Units
6004258	Inner Zone Flowmeter	1	Prior to Ser No/11
6100302	Inner Zone Flowmeter	1	Ser No/11 on
6004395	Replacement Flowmeter Tube	1	All Units
6004259	Exhaust Control Valve	1	
6004260	8mm External Dia Pipe Coupling	1	
6006437	Power Neon	1	
6006439	Heater Neon	1	Prior to Ser No/16
6007564	Thermocouple	1	
6500117	Solid State Relay	1	Ser No/16 on

ACCESSORIES.

Part No	Description.
6001946	Hose nozzle for 9.5mm bore hose
F5915	Air pressure regulator and filter

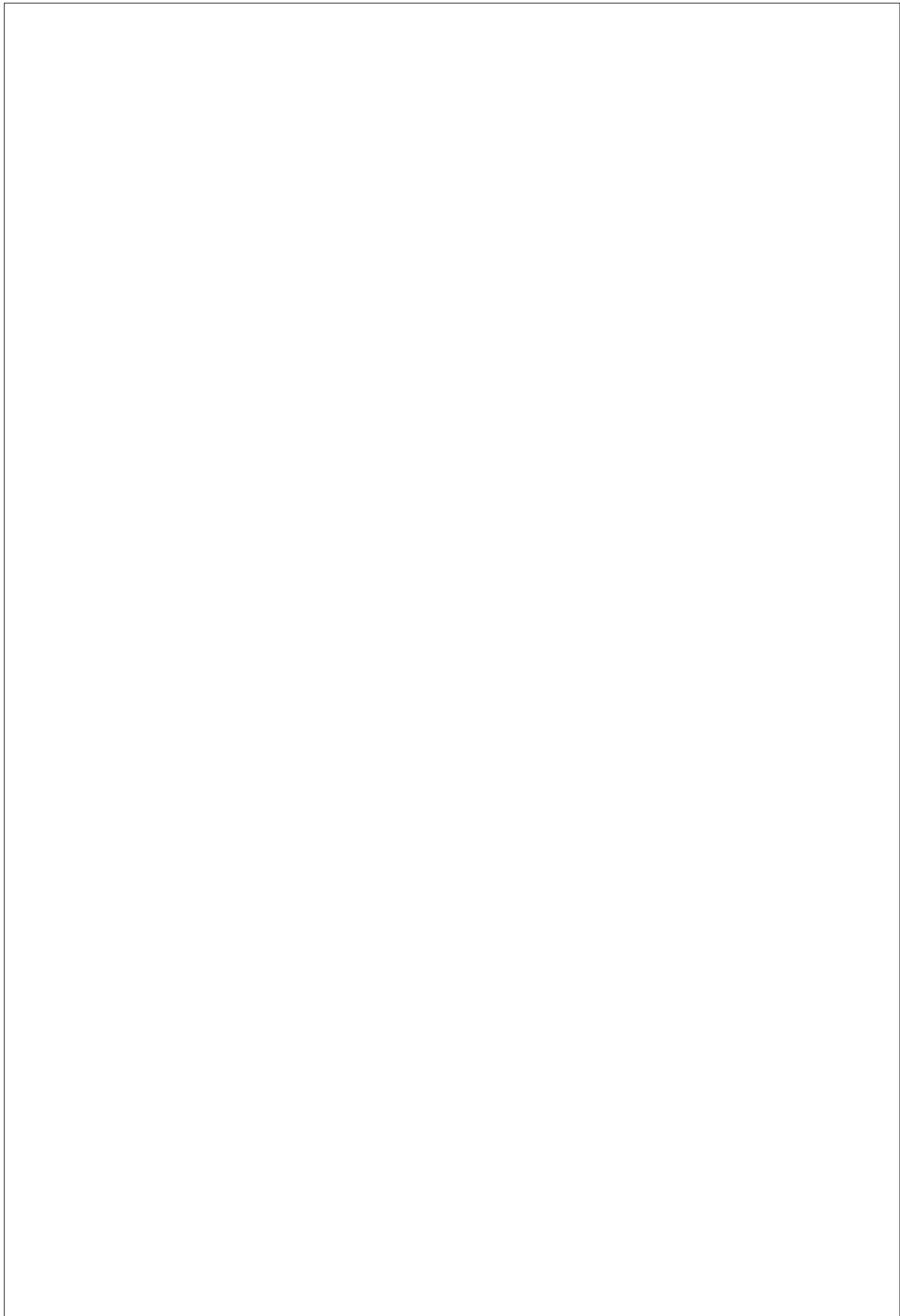



Thank you for reading this data sheet.

For pricing or for further information, please contact us at our UK Office, using the details below.



UK Office

Keison Products,

P.O. Box 2124, Chelmsford, Essex, CM1 3UP, England.

Tel: +44 (0)330 088 0560

Fax: +44 (0)1245 808399

Email: sales@keison.co.uk

Please note - Product designs and specifications are subject to change without notice. The user is responsible for determining the suitability of this product.