

FB-08 Fluidised Bath

OPERATOR'S MANUAL

IMPORTANT SUPPLEMENTARY SAFETY INFORMATION

Introduction

Techne fluidised baths are safe and effective equipment when installed and operated correctly in accordance with the user manual. However, if used incorrectly they can pose a safety risk. Techne have designed all models of fluidised baths to protect operators from hazards but users should pay attention to the following points.



Caution

1. Please read the user manual before installation and use.
2. Techne fluidised baths can heat up to 600°C, 700°C or even 1100°C. High temperatures are dangerous and can cause serious burns to operators and ignite combustible material.
3. Use care and wear protective gloves to protect hands and protective glasses to protect eyes.
4. Do not put hot objects on or near combustible objects.
5. Do not operate the unit close to inflammable liquids or gases.
6. Do not place any liquid directly in the unit.
7. Always ensure a suitable, adequate ventilation system is used when equipment is in use.
8. Always install fireproof metal ducting with sufficient airflow.

Maintenance

1. When performing maintenance always disconnect from power supply and cool below 50°C.
2. Techne recommend regular cleaning of fluidised baths. Externally, wipe with a damp soapy cloth. No abrasive cleaners. Care should be taken to prevent any water entering the unit.
3. Regular internal and external inspection of extraction ducting is recommend to detect any damage and ensure the internals are clean. Any build-up of particles or debris discovered in the extraction ducting requires the ducting to be cleaned or replaced.
4. In fluidised baths used for polymer burn-off, please regularly inspect fluidising medium, remove any foreign debris and replace with clean fluidising medium as required.
5. Never top-up a hot fluidised bath with cold fluidising medium. Always cool below 50°C first.

Please note

1. Please ensure an adequate risk assessment is performed before use of a fluidised bath.
2. Please ensure the appropriate temperature is used for the application, always stay safely below the combustion temperature of any material or sample in a fluidised bath.
3. Fluidising airflow must be switched on before heating a fluidised bath, and left operational until the baths cools to below 50°C unless performing dead-bed calibration function.
4. Do not overfill fluidising media. The fill-level is 6 inches (15cm) below top surface when cold.
5. In fluidised baths used for polymer burn-off, always remove excess polymer from sample.
6. In applications where materials being treated produce acidic vapours during thermal decomposition, it is recommended a fume scrubber is utilised to ensure fume emission from the plant conforms to local regulations.
7. If you have any questions please contact technehelp@bibby-scientific.com.

FB-08 OPERATOR'S MANUAL

CONTENTS	PAGE
SAFETY and INSTALLATION	
English	2
Français	4
Deutsch	7
Español	10
Italiano	13
INTRODUCTION	16
Application	16
OPERATOR SAFETY	17
Guarantee	18
Contact information	18
TECHNICAL SPECIFICATION	19
INSTALLATION	20
Controls	21
OPERATION	23
Start Up	23
Calibration	24
Dead Bed Calibration	24
Close Down	24
SERVICING	25
Daily Maintenance	25
Periodic Maintenance	25
FAULT FINDING	26
COMPONENT ACCESS	28
SPARES LIST	31
ACCESSORIES	31
DIAGRAMS	32

SAFETY AND INSTALLATION

Please read all the information in this booklet before using the unit.

WARNING

HIGH TEMPERATURES ARE DANGEROUS: they can cause serious burns to operators and ignite combustible material.

Techne have taken great care in the design of these units to protect operators from hazards, but users should pay attention to the following points:

- USE CARE AND WEAR PROTECTIVE GLOVES TO PROTECT HANDS.
- DO NOT put hot objects on or near combustible objects.
- DO NOT operate the unit close to inflammable liquids or gases.
- DO NOT place any liquid directly in your unit.
- At all times USE COMMON SENSE.

OPERATOR SAFETY

All users of Techne equipment must have available the relevant literature needed to ensure their safety. It is important that only suitably trained personnel operate this equipment, in accordance with the instructions contained in this manual and with general safety standards and procedures. If the equipment is used in a manner not specified by Techne the protection provided by the equipment to the Operator may be impaired.

All Techne units have been designed to conform to international safety requirements and are fitted with an overtemperature cut-out. On some models, the cut-out is adjustable and should be set to suit the application. On all other models the cut-out is preset to protect the unit.

If a safety problem should be encountered, switch off at the mains socket and remove the plug from the supply.

INSTALLATION

1. All Techne units are supplied with a power cable. This may be integral or plug-in.
2. Before connecting the mains supply, check the voltage against the rating plate. Connect the mains cable to a suitable plug according to the table below. Note that the unit must be earthed to ensure proper electrical safety.

<i>Connections</i>	<i>220/240V</i>	<i>110/120V</i>
Live	Brown	Black
Neutral	Blue	White
Earth	Green/yellow	Green

The fused plug supplied with the mains lead for use in the UK is fitted with the following value fuse to protect the cable: 230V UK 13 AMP The fuse in the unit protects the unit and the operator.

Note that units marked 230V on the rating plate work at 220V; units marked 120V work at 110V. In both cases, however, the heating rate will degrade by approximately 8%.

The rating plate is on the rear of the unit.

3. Plug the mains cable into the socket on the rear of the unit.
4. Place the unit on a suitable bench or flat workspace, or in a fume cupboard if required, ensuring that the air inlet vents on the underside are free from obstruction.

5. Note that the following symbol next to the indicator lamp on the front panel of the units and has the following meanings:
 ~ : the power indicator
6. Symbols on or near the power switch of the unit have the following meanings:
I : mains switch On
O : mains switch Off

AFTER USE

When you have finished heating samples, remember that parts of the unit – the tubes, blocks and associated accessories – may be very hot. Take the precautions listed earlier.

GUARANTEE

The unit is guaranteed against any defect in material or workmanship for the period specified on the enclosed guarantee card. This period is from the date of purchase, and within this period all defective parts will be replaced free of charge provided that the defect is not the result of misuse, accident or negligence. Servicing under this guarantee should be obtained from the supplier.

Notwithstanding the description and specification(s) of the units contained in the Operator's Manual, Techne hereby reserves the right to make such changes as it sees fit to the units or to any component of the units.

This Manual has been prepared solely for the convenience of Techne customers and nothing in this Instruction Book shall be taken as a warranty, condition or representation concerning the description, merchantability, fitness for purpose or otherwise of the units or components.

OPERATOR MAINTENANCE

NOTE: THAT THIS EQUIPMENT SHOULD ONLY BE DISMANTLED BY PROPERLY TRAINED PERSONNEL. REMOVING THE SIDE, FRONT OR REAR PANELS EXPOSES POTENTIALLY LETHAL MAINS VOLTAGES. THERE ARE NO OPERATOR MAINTAINABLE PARTS WITHIN THE EQUIPMENT.

In the unlikely event that you experience any problems with your unit which cannot easily be remedied, you should contact your supplier and return the unit if necessary. Please include any details of the fault observed and remember to return the unit in its original packing. Techne accept no responsibility for damage to units which are not properly packed for shipping: if in doubt, contact your supplier. See the Decontamination Certificate supplied with your unit.

1. Cleaning

Before cleaning your unit ALWAYS disconnect it from the power supply and allow it to cool below 50°C.

Your unit can be cleaned by wiping with a damp soapy cloth. Care should be exercised to prevent water from running inside the unit. Do not use abrasive cleaners.

2. Fuses

Your unit is protected by one or two fuses. These should only be changed by suitably qualified personnel. If the fuses blow persistently, a serious fault is indicated and you may need to return the unit to your supplier for repair.

INTRODUCTION

Veuillez lire attentivement toutes les instructions de ce document avant d'utiliser l'appareil.

AVERTISSEMENT

DANGER DE TEMPERATURES ELEVEES : les opérateurs peuvent subir de graves brûlures et les matériaux combustibles risquent de prendre feu.

Techne a apporté un soin tout particulier à la conception de ces appareils de façon à assurer une protection maximale des opérateurs, mais il est recommandé aux utilisateurs de porter une attention spéciale aux points suivants :

- PROCEDER AVEC SOIN ET PORTER DES GANTS POUR SE PROTEGER LES MAINS.
- NE PAS poser d'objets chauds sur ou près de matériaux combustibles.
- NE PAS utiliser l'appareil à proximité de liquides ou de gaz inflammables.
- NE PAS verser de liquide directement dans l'appareil.
- FAIRE TOUJOURS PREUVE DE BON SENS.

SÉCURITÉ DE L'OPÉRATEUR

Tous les utilisateurs de produits Techne doivent avoir pris connaissance des manuels et instructions nécessaires à la garantie de leur sécurité.

Important : cet appareil doit impérativement être manipulé par un personnel qualifié et utilisé selon les instructions données dans ce document, en accord avec les normes et procédures de sécurité générales. Dans le cas où cet appareil ne serait pas utilisé selon les consignes précisées par Techne, la protection pour l'utilisateur ne serait alors plus garantie.

Tous les appareils Techne sont conçus pour répondre aux normes de sécurité internationales et sont dotés d'un coupe-circuit en cas d'excès de température. Sur certains modèles, ce coupe-circuit est réglable pour s'adapter à l'application désirée. Sur d'autres modèles, il est pré-réglé en usine pour assurer la protection de l'appareil.

Dans le cas d'un problème de sécurité, coupez l'alimentation électrique au niveau de la prise murale et enlevez la prise connectée à l'appareil.

INSTALLATION

1. Tous les appareils Techne sont livrés avec un câble d'alimentation qui peut être intégré à l'appareil ou à raccorder.
2. Avant de brancher l'appareil, vérifiez la tension requise indiquée sur la plaque d'identification. Raccordez le câble électrique à la prise appropriée en vous reportant au tableau ci-dessous. Il est important que l'appareil soit relié à la terre pour assurer la protection électrique requise.

<i>Connexions</i>	<i>220V-240 V</i>	<i>110V-120 V</i>
Phase	marron	noir
Neutre	bleu	blanc
Terre	vert/jaune	vert

Le fusible à l'intérieur de l'appareil est destiné à assurer la protection de l'appareil et de l'opérateur.

Remarque : les appareils dont la plaque indique 230 V peuvent fonctionner sur 220 V, et ceux dont la plaque indique 120 V peuvent fonctionner sur 110 V. Dans les deux cas cependant, la capacité de chauffage diminuera d'environ 8 %. La plaque d'identification se trouve à l'arrière de l'appareil.

3. Raccordez le câble d'alimentation à la prise située à l'arrière de l'appareil.
4. Placez l'appareil sur un plan de travail ou surface plane, ou le cas échéant, dans une hotte d'aspiration, en s'assurant que les trous d'aération situés sous l'appareil ne soient pas obstrués.
5. Les symboles ci-dessous situés à côté des témoins lumineux sur la face avant de l'appareil ont la signification suivante: ~ : témoin d'alimentation.
6. Les symboles situés sur ou à côté de l'interrupteur de l'appareil ont la signification suivante :
 - I arrêt
 - O marche

APRÈS UTILISATION

Lorsque vous avez fini de chauffer les échantillons, n'oubliez pas que certaines parties de l'appareil - les éprouvettes, leurs supports et autres accessoires - risquent d'être très chaudes. Il est donc recommandé de toujours prendre les précautions citées plus haut.

GARANTIE

L'appareil est garanti contre tout défaut ou visde fabrication pour la durée figurant sur la carte de garantie, à compter de la date d'achat de l'appareil. Au cours de cette période, toutes les pièces défectueuses seront remplacées gratuitement, dans la mesure où la défaillance n'est pas due à une mauvaise utilisation, un accident ou une négligence. Toute réparation sous garantie sera effectuée par le fournisseur.

Malgré la description et les spécifications de l'appareil données dans le manuel de l'utilisateur, Techne se réserve le droit d'effectuer les changements nécessaires à l'appareil ou à tout élément qui entre dans sa composition.

Ce manuel a été exclusivement rédigé à l'attention des clients de Techne, et aucun élément de ce guide d'instructions ne peut être utilisé comme garantie, condition ou représentation concernant la description, commercialisation, adaptation aux conditions d'utilisation ou autre des appareils ou leurs composants.

ENTRETIEN UTILISATEUR

IMPORTANT : CET APPAREIL NE PEUT ETRE DEMONTE QUE PAR DU PERSONNEL QUALIFIE.

LORSQUE LES PANNEAUX AVANT, ARRIERE ET LATERAUX SONT DEMONTES, L'OPERATEUR EST EXPOSE A DES TENSIONS QUI PEUVENT ETRE MORTELLES.

CET APPAREIL NE CONTIENT AUCUN ELEMENT QUI DEMANDE UN ENTRETIEN DE LA PART DE L'UTILISATEUR.

Dans le cas peu probable où votre appareil présente un défaut de fonctionnement auquel il est difficile de remédier, il est alors préférable de contacter votre fournisseur et, le cas échéant, de renvoyer le matériel. Veuillez inclure une description détaillée du problème constaté et retourner l'appareil dans son

emballage d'origine. Techne ne sera pas tenu responsable des dommages subis par tout appareil dont l'emballage est inadéquat pour le transport. Pour plus de sûreté, contactez votre fournisseur. Voir le certificat de décontamination livré avec le produit.

1. Nettoyage

Avant de nettoyer l'appareil, assurez-vous TOUJOURS que le câble d'alimentation est déconnecté et laissez la température redescendre en dessous de 50 °C.

Utilisez un chiffon imprégné d'eau savonneuse pour nettoyer l'appareil. Veillez à ne pas introduire d'eau dans l'appareil. N'utilisez pas de produits abrasifs.

2. Fusibles

La protection de l'appareil est assurée par un ou deux fusibles dont le remplacement ne peut être effectué que par un personnel qualifié.

Si les fusibles sautent sans arrêt, il s'agit d'un problème sérieux. Nous vous conseillons dans ce cas de prendre contact avec votre fournisseur pour réparation.

EINLEITUNG

Bitte lesen Sie diese Bedienungsanleitung komplett bevor Sie dieses Gerät benutzen.

WARNUNG

HOHE TEMPERATUREN SIND GEFÄHRLICH: sie können dem Bediener ernsthafte Verletzungen zufügen und brennbare Materialien können sich leicht entzünden.

Techne hat bei der Konstruktion dieses Gerätes sehr darauf geachtet, daß der Bediener vor Gefahren geschützt ist. Dennoch sollten Sie auf die folgenden Punkte achten:

- SEIEN SIE VORSICHTIG UND TRAGEN SIE SCHUTZHANDSCHUHE.
- Legen Sie heiße Gegenstände NICHT auf oder in die Nähe von leicht brennbaren Materialien. vermeiden Sie Arbeiten in der Nähe von leicht entzündbaren Flüssigkeiten oder Gasen.
- Bringen sie KEINE Flüssigkeiten direkt in Ihr Gerät.
- Benutzen Sie immer den normalen Menschenverstand.

SICHERHEIT DES ANWENDERS

Alle Benutzer von Techne Geräten müssen Zugang zu der entsprechenden Literatur haben, um ihre Sicherheit zu gewähren.

Es ist wichtig, daß diese Geräte nur von entsprechend geschultem Personal betrieben werden, das die in dieser Gebrauchsanweisung enthaltenen Maßnahmen und allgemeine Sicherheitsbestimmungen und -vorkehrungen beachtet. Wenn das Gerät anders eingesetzt wird als vom Hersteller empfohlen, kann dies die persönliche Sicherheit des Anwenders beeinträchtigen. Die Geräte von Techne entsprechen den internationalen Sicherheitsbestimmungen und sind mit einem automatischen Übertemperaturabschalter ausgestattet. Bei einigen Modellen ist der Übertemperaturabschalter verstellbar und sollte je nach Anwendung entsprechend eingestellt werden. Bei allen anderen Modellen ist der Temperaturschutz voreingestellt um Schäden am Gerät zu vermeiden. Wenn ein Sicherheitsproblem auftreten sollte, muß das Gerät ausgeschaltet und vom Stromnetz getrennt werden.

INSTALLATION

1. Alle Techne Geräte werden mit einem Stromanschlußkabel geliefert. Dieses ist entweder fest mit dem Gerät verbunden oder zum Einstecken.
2. Vergleichen Sie, ob die Spannung Ihrer Stromversorgung mit den Angaben auf dem Typenschild des Geräte übereinstimmen. Verbinden Sie das Stromanschlußkabel mit einer geeigneten Stromversorgung gemäß der nächstehenden Tabelle.

Achtung: Das Gerät muß geerdet sein, um die elektrische Sicherheit zu gewährleisten!

<i>Verbindungen</i>	220V-240V	110V-120V
Stromführend	Braun	Schwarz
Neutral	Blau	Weiß
Erde	Grün/Gelb	Grün

Geräte, die für 230 Volt ausgelegt sind, können auch bei 220 Volt arbeiten, Geräte für 120 Volt auch bei 110 Volt. In beiden Fällen verringert sich die Aufheizrate um ca. 8%. Das Typenschild befindet sich hinten am Gerät.

3. Stecken Sie das Stromkabel in die vorgesehene Buchse hinten am Gerät.

4. Stellen Sie das Gerät auf eine ebene Arbeitsfläche bzw. (falls erforderlich) unter einen Laborabzug. Beachten Sie, daß die Entlüftungsrippen an der Geräteunterseite immer frei zugänglich sind.
5. Wenn die Anzeigenlampchen an der Vorderseite leuchten, hat dies folgende Bedeutung:
~ : Gerät ist eingeschaltet.
6. Die Symbole auf oder neben dem EIN/AUS-Schalter an der Geräterückseite bedeuten:
I An
O Aus

NACH DEM GEBRAUCH

Vergessen Sie nicht, daß Teile des Gerätes (die Gefäße, die Blöcke und andere Zubehörteile) nach dem Erhitzen von Proben noch sehr heiß sein können. Bitte beachten Sie die oben genannten Vorsichtsmaßnahmen.

GARANTIE

Die Garantiedauer des Gerätes ist auf der beiliegenden Garantiekarte angegeben und schließt Fehler im Material oder der Verarbeitung ein. Die Garantiedauer beginnt am Tag des Einkaufs. Sämtliche defekte Teile werden innerhalb dieses Zeitraumes kostenlos ersetzt unter der Voraussetzung, daß dem Defekt keine unsachgemäße Handhabung, Fahrlässigkeit oder ein Unfall zugrundeliegt. Der unter diese Garantie fallende Service wird vom Lieferanten geleistet.

Ungeachtet der in dieser Gebrauchsanweisung enthaltenen Beschreibungen und Spezifikationen, behält sich Techne hiermit das Recht vor, Änderungen an den Geräten bzw. an einzelnen Geräteteilen durchzuführen.

Diese Gebrauchsanleitung wurde ausschließlich dazu erstellt, um Kunden die Handhabung der Techne-Geräte zu erleichtern. Nichts in dieser Gebrauchsanleitung darf als Garantie, Bedingung oder Voraussetzung verstanden werden, sei es die Beschreibung, Marktgängigkeit, Zweckdienlichkeit oder sonstiges bezüglich der Geräte oder deren Bestandteile.

WARTUNG DURCH DEN BEDIENER

BEACHTEN SIE, DASS DIESES GERÄT NUR VON TECHNISCHEN FACHKRÄFTEN GEÖFFNET UND DEMONTIERT WERDEN DARF.

DURCH ENTFERNEN DES GERÄUSES ODER GEHÄUSETEILEN SIND BAUTEILE MIT LEBENGEFÄHRLICHEN SPANNUNGEN FREI ZUGÄNLICH.

IM INNERN DES GERÄTES BEFINDEN SICH KEINE TEILE, DIE VOM ANWENDER GEWARTET WERDEN MÜSSEN.

Falls Ihr Gerät nicht ordnungsgemäß arbeitet, wenden Sie sich an Ihren Lieferanten oder senden Sie das Gerät wenn nötig zurück. Fügen Sie eine genaue Beschreibung des Defektes bei. Verpacken Sie das Gerät möglichst im Originalkarton. Bitte beachten Sie, daß Techne und thermo-DUX keine Haftung bei Transportschäden aufgrund unzureichender Verpackung übernehmen. Setzen Sie sich im Zweifelsfall mit Ihrem Lieferanten in Verbindung. Bitte beachten Sie die Entgiftungsbescheinigung, die Sie mit dem Gerät erhalten haben.

1. Reinigen

Bevor Sie Ihr Gerät reinigen, sollten Sie

- zuerst den Netzstecker ziehen.
- das Gerät unter 50°C abkühlen lassen.

Ein feuchtes Tuch mit Seifenlösung reinigt Ihr Gerät am besten. Achten Sie darauf, daß kein Wasser in das Gerät gelangt. Verwenden Sie keine Scheuermittel.

2. Sicherungen

Die Stromzuleitung ist durch ein oder zwei Sicherungen geschützt. Diese sollten nur durch qualifiziertes Fachpersonal ausgetauscht werden. Wenn die Sicherung wiederholt durchbrennt, liegt ein größerer Defekt vor. Das Gerät muß zur Reparatur an Ihren Lieferanten eingesandt werden.

INTRODUCCIÓN

Le rogamos lea cuidadosamente la información contenida en este folleto antes de manipular el aparato.

AVISO

LAS TEMPERATURAS ELEVADAS SON PELIGROSAS: pueden causarle graves quemaduras y provocar fuego en materiales combustibles.

Techne ha puesto gran cuidado en el diseño de estos aparatos para proteger al usuario de cualquier peligro; aún así se deberá prestar atención a los siguientes puntos:

- EXTREME LAS PRECAUCIONES Y UTILICE GUANTES PARA PROTEGERSE LAS MANOS.
- NO coloque objetos calientes encima o cerca de objetos combustibles.
- NO maneje el aparato cerca de líquidos inflamables o gases.
- NO introduzca ningún líquido directamente en el aparato.
- UTILICE EL SENTIDO COMUN en todo momento.

SEGURIDAD DEL USUARIO

Todos los usuarios de equipos Techne deben disponer de la información necesaria para asegurar su seguridad.

De acuerdo con las instrucciones contenidas en este manual y con las normas y procedimientos generales de seguridad, es muy importante que sólo personal debidamente capacitado opere estos aparatos. De no ser así, la protección que el equipo le proporciona al usuario puede verse reducida.

Todos los equipos Techne han sido diseñados para cumplir con los requisitos internacionales de seguridad y traen incorporados un sistema de desconexión en caso de sobretemperatura. En algunos modelos el sistema de desconexión es variable, lo que le permite elegir la temperatura según sus necesidades. En otros, el sistema de desconexión viene ya ajustado para evitar daños en el equipo.

En caso de que surgiera un problema de seguridad, desconecte el equipo de la red.

INSTALACIÓN

1. Todos los aparatos Techne se suministran con un cable de alimentación. Puede ser fijo o independiente del aparato.
2. Antes de conectarlo, compruebe que el voltaje corresponde al de la placa indicadora. Conecte el cable de alimentación a un enchufe adecuado según la tabla expuesta a continuación. El equipo debe estar conectado a tierra para garantizar la seguridad eléctrica.

<i>Conexiones</i>	<i>220V-240V</i>	<i>110V-120V</i>
Línea	Marrón	Negro
Neutro	Azul	Blanco
Tierra	Verde/amarillo	Verde

Asegúrese de que los equipos marcados 230V en la placa indicadora funcionan a 220V y de que los equipos marcados 120V funcionan a 110V. No obstante, en ambos casos la velocidad de calentamiento se verá reducida en un 8% aproximadamente. La placa indicadora está situada en la parte posterior del equipo.

3. Conecte el cable a la toma de tensión en la parte posterior del equipo.
4. Sitúe el aparato en un lugar apropiado tal como una superficie de trabajo plana, o si fuera necesario incluso en una campana con extractor de humos, asegurándose de que las entradas de aire en la parte inferior no queden obstruidas.
5. Los símbolos, que pueden aparecer junto a las luces indicadoras en el panel frontal del equipo, tienen los siguientes significados: ~: Indicador de potencia.
6. Los símbolos que se encuentran en o cerca del interruptor de alimentación tienen los siguientes significados:
 - I Interruptor principal encendido
 - O Interruptor principal apagado

DESPUÉS DE SU USO

Cuando haya finalizado el calentamiento de muestras, recuerde que las piezas del equipo, tales como tubos, bloques y demás accesorios, pueden estar muy calientes. Tome las precauciones mencionadas anteriormente.

GARANTÍA

Este aparato está garantizado contra cualquier defecto material o de fabricación durante el periodo especificado en la tarjeta de garantía adjunta. Este plazo inicia a partir de la fecha de compra, y dentro de este periodo todas las piezas defectuosas serán reemplazadas gratuitamente siempre que el defecto no sea resultado de un uso incorrecto, accidente o negligencia. Mientras se encuentre bajo garantía las revisiones las debe llevar a cabo el proveedor.

A pesar de la descripción y las especificaciones de los aparatos contenidas en el Manual del Usuario, Techne se reserva por medio de este documento el derecho a efectuar los cambios que estime oportunos tanto en los aparatos como en cualquier componente de los mismos.

Este manual ha sido preparado exclusivamente para los clientes de Techne y nada de lo especificado en este folleto de instrucciones se tomará como una garantía, condición o aseveración de la descripción, comerciabilidad o adecuación para cualquier fin específico de los aparatos o sus componentes.

MANTENIMIENTO

ESTE APARATO DEBE SER DESMONTADO SOLO Y EXCLUSIVAMENTE POR PERSONAL DEBIDAMENTE CAPACITADO.

EL RETIRAR LOS PANELES LATERALES, FRONTALES O TRASEROS SUPONE DEJAR AL DESCUBIERTO TENSION DE LA RED PELIGROSA.

EL EQUIPO NO CONSTA DE NINGUNA PIEZA DE CUYO MANTENIMIENTO SE PUEDA ENCARGAR EL USUARIO.

En el caso improbable de que experimentara algún problema con su aparato que no pudiera resolver con facilidad, debería ponerse en contacto con su proveedor y devolverlo si fuera necesario. Indique de forma detallada todos los defectos que haya notado y devuelva el equipo en su embalaje original. Techne no aceptará responsabilidad alguna por daños causados en equipos que no estuvieran debidamente embalados para su envío; si tuviera alguna duda, póngase en contacto con su proveedor. Sírvase consultar el Certificado de Descontaminación suministrado con su aparato.

1. Limpieza

Antes de limpiar su aparato, desconéctelo SIEMPRE de la fuente de alimentación y permita que se enfríe por debajo de los 50°C.

Este aparato se puede limpiar pasándole un paño húmedo enjabonado. Hágalo con cuidado para evitar que caiga agua dentro del mismo. No utilice limpiadores abrasivos.

2. Fusibles

Su aparato está protegido por uno o dos fusibles. Sólo deben cambiarlos personal debidamente capacitado.

Si los fusibles se fundieran repetidamente, esto indicaría una avería grave y puede que tuviera que devolverle el aparato a su proveedor para su reparación.

INTRODUZIONE

Prima di utilizzare l'apparecchio, leggere tutte le informazioni contenute in questo manuale.

ATTENZIONE

Le alte temperature sono pericolose: possono causare ustioni gravi all'utilizzatore e possono causare la combustione di materiale infiammabile. La Techne ha posto particolare cura nel progettare questo strumento, al fine di proteggere gli operatori da eventuali pericoli, ma gli utilizzatori devono prestare attenzione ai seguenti punti:

- Utilizzare con attenzione e indossare guanti protettivi.
- Non mettere vicini oggetti caldi o oggetti infiammabili.
- Non azionare il riscaldatore Techne vicino a liquidi infiammabili o benzine.
- Non introdurre nessun liquido all'interno dell'unità.
- In ogni caso Usare Buon Senso.

SICUREZZA PER L'UTILIZZATORE

Il personale che utilizza l'apparecchiatura Techne deve avere a disposizione la documentazione necessaria al fine di assicurare la loro incolumità.

È importante che solo personale adeguatamente addestrato utilizzi questo apparecchio, in conformità alle istruzioni contenute in questo manuale e nel rispetto delle normative e procedure generali di sicurezza. Se l'apparecchio è utilizzato in modo non specificato da Techne, la protezione fornita dall'apparecchiatura all'utilizzatore potrebbe essere a rischio.

Tutte le unità Techne sono state progettate in conformità ai requisiti internazionali di sicurezza e sono equipaggiate con un interruttore anti surriscaldamento. Su alcuni modelli, l'interruttore è regolabile e dovrebbe essere impostato secondo l'utilizzo. In tutti gli altri modelli l'interruttore è preregolato per proteggere l'unità.

Se si dovesse verificare qualche problema di sicurezza, disconnettere l'apparecchio dalla rete.

INSTALLAZIONE

1. Tutti gli apparecchi Techne sono forniti di un cavo di alimentazione. Questo può essere integrato nell'apparecchio o separato.
2. Prima di collegare l'apparecchio alla presa di alimentazione, controllare il voltaggio indicato sulla targhetta. La targhetta identificativa si trova sul retro dell'apparecchio. Collegare il cavo di alimentazione in una presa appropriata secondo la tabella seguente.

L'apparecchio deve essere collegato alla messa a terra per assicurare la giusta sicurezza elettrica.

<i>Connessioni</i>	<i>220V-240V</i>	<i>110V-120V</i>
Tensione	Marrone	Nera
Neutro	Blu	Bianco
Terra	Verde/Giallo	Verde

Il fusibile all'interno dell'apparecchio protegge l'apparecchiatura e l'utilizzatore.

Tenere presente che gli apparecchi riportanti sulla targhetta 230 V funzionano a 220V. Gli apparecchi riportanti 120V funzionano a 110V. Comunque, in entrambi i casi la velocità di riscaldamento diminuirà approssimativamente dell'8%.

3. Collegare il cavo elettrico alla presa di corrente sul retro dell'unità.
4. Posizionare l'unità su un luogo adeguato, su una superficie di lavoro piana oppure, se necessario, sotto una cappa aspiratrice, assicurandosi che le prese di aria sulla parte inferiore siano libere da ostruzione.
5. I simboli seguenti, che possono essere collocati in prossimità delle luci di indicazione sul pannello anteriore dell'apparecchio, hanno i seguenti significati:

- I Acceso
- O Spento

DOPO L'USO

Quando avrete terminato di riscaldare i campioni, ricordate che le parti dell'apparecchio – le provette, i loro supporti e gli altri accessori – possono essere bollenti. Seguire le precauzioni elencate in precedenza.

GARANZIA

L'apparecchio è garantito contro ogni difetto del materiale o fabbricazione per il periodo specificato sul certificato di garanzia accluso. Questo periodo decorre dalla data di acquisto, e durante il quale tutte le parti difettose verranno sostituite gratuitamente purché il difetto non sia causato da un uso non appropriato, da cause non imputabili a difetti di fabbricazione o negligenza. L'assistenza durante questo periodo sarà garantita dal fornitore.

Ferme restando la descrizione e le caratteristiche dell'apparecchio contenute nel Manuale d'uso dell'utilizzatore, la Techne si riserva in ogni caso il diritto di effettuare le modifiche che riterrà necessarie all'apparecchio o ai suoi componenti.

Questo Manuale è stato realizzato esclusivamente a vantaggio dei clienti della Techne e in alcun modo potrà essere utilizzato come garanzia, condizione o rappresentazione concernente la descrizione, commercializzazione, adeguamento alle condizioni di utilizzo o altro degli apparecchi o delle sue componenti.

MANUTENZIONE

Questo apparecchio dovrà essere aperto esclusivamente da Personale adeguatamente addestrato. La rimozione dei pannelli laterali, frontali o posteriori può esporre potenzialmente a voltaggi di corrente letali. All'interno dell'apparecchio non ci sono parti manutenibili da parte dell'utilizzatore.

Nell'eventualità che si riscontri un problema con l'apparecchio che non può essere facilmente risolto, si dovrà contattare il proprio fornitore e restituire, se necessario, l'apparecchio. Si prega di specificare nel dettaglio i difetti riscontrati e di ricordare di restituire l'apparecchio nel suo involucro originale. La Techne non si fa carico di alcuna responsabilità per danni subiti dall'apparecchio che non sia stato propriamente

imballato per il trasporto; in caso di dubbio, rivolgersi al fornitore. Vedere il Certificato di Decontaminazione fornito con il vostro apparecchio.

1. Pulizia

Prima di pulire il vostro apparecchio, disconnettere sempre la presa di alimentazione e lasciare raffreddare sotto i 50° C. Questo apparecchio può essere pulito passando un panno inumidito con sapone. Si deve prestare attenzione onde prevenire l'ingresso dell'acqua all'interno dell'apparecchio. Non utilizzare per la pulizia sostanze abrasive.

2. Fusibili

L'apparecchio è protetto da uno o due fusibili. Questi dovrebbero essere sostituiti solo da personale qualificato. Se i fusibili si bruciano frequentemente ciò indica un malfunzionamento serio e in questo caso si consiglia di contattare il fornitore per le riparazioni.

INTRODUCTION

Read the whole of this book before commencing work with the unit.

The Techne FB-08 employs the principle of fluidisation of a mass of finely divided particles to provide a safe, essentially isothermal environment with a high rate of heat transfer.

To achieve a state of fluidisation, a gas stream is forced to pass vertically through the bed of fine powder; chromatographic alumina (a specially refined grade of aluminium oxide) is the fluidising medium used in the FB-08. At, and above, a certain critical value of flow rate the particles become separated from each other and the whole mass behaves like a liquid. In this state the powder will flow and move as though it were a liquid; low density objects will float on it, while more dense ones will sink; more importantly, though, the individual alumina particles will circulate within the bath giving an essentially uniform temperature distribution throughout the working volume of the bath, and a high degree of thermal coupling between the heat source and load.

In addition, the mass of fluidised powder changes its basic characteristics very little over a wide temperature range, has no freezing point and no practical boiling point and therefore by suitable choice of fluidising media, the principle of fluidisation can be used to temperatures over 1700°C and below -120°C.

The most commonly used fluidising gas is compressed air, it is important that it should be clean, dry, free from oil and at a constant pressure. Techne can supply an additional filter/regulator assembly for compressed air which does not comply with the above requirement. Techne are alternatively able to offer a suitable free standing air compressor complete with the necessary filtration system for installations where a compressed air supply is not available. Any other gas could be used for special applications provided appropriate precautions are taken. The FB-08 specification applies only when compressed air is used.

APPLICATION

The characteristics of the FB-08 in terms of thermal uniformity and heat transfer make it a useful tool in the calibration and testing of a very wide range of temperature sensors; however, the unit is applicable to many other processes, such as thermal testing of sensitive components eg semiconductor devices, wire products, delicate transducers - and can be used as a constant temperature environment for chemical reactions.

Because the fluidised bed is composed of a fine dry powder, it does not display the surface tension effects of liquid baths, and does not wet any objects immersed in it; the basic electrical insulating property of the alumina used in the FB-08 is not affected by fluidisation, making it possible to conduct electrical measurements on immersed objects such as assembled printed circuit boards. If the FB-08 is to be used below ambient see Page 9. Avoid siting the FB-08 in a laboratory environment which contains instruments that are sensitive to dust. Although the fluidised bath has its own dust extraction system, a small amount of fine dust may still be emitted during operation.

OPERATOR SAFETY

It is important that only suitably trained personnel operate this equipment. It must also be used in accordance with the instructions contained in this manual and with proper safety standards and procedures.

It is imperative that all personnel who may come into contact with our equipment have available such of our literature as they require to ensure their safety.

If there is any doubt whatsoever relating to the proper use of this equipment we will be pleased to assist you.

It is advisable to read the whole of this book before commencing work with the unit.

WARNING

Poor fluidisation causes hot spots, heater failure, and damage to other parts. Follow instruction book carefully. For correct fluidisation, pay attention to;

INSTALLATION

Ensure bath is level and air supply is adequate.

OPERATION

Adjust air valve for even fluidisation.

Do not insert objects larger than recommended.

Ensure objects do not lie in contact with container wall or porous plate.

MAINTENANCE

Regularly inspect and maintain air filter to eliminate oil vapour in air supply.

ALUMINA

Should the fluidised bath be stirred for a long period of time under damp or humid conditions, moisture may be absorbed by the alumina which is hygroscopic. To avoid violent fluidisation which occurs when damp alumina is heated above 100°C, operate the bath for a period of approximately 8 hours at 90°C prior to operation at elevated temperatures.

NEVER ADD COLD OR DAMP ALUMINA TO A HOT BATH AS THIS WILL ALSO CAUSE VIOLENT FLUIDISATION WHICH CAN BE DANGEROUS. Allow the bath to cool then add the fresh alumina. If this fresh alumina is a large portion of the charge then dry the whole charge as above.

FUME EXTRACTION

When used for processing items which may emit toxic or inflammable fumes, it is essential that an adequate fume extraction system be installed. The extraction system must be correctly sized to ensure that any toxic fumes are removed from the working environment.

To eliminate the risk of spontaneous ignition, the concentration of inflammable fumes above the bath and within the exhaust duct work must be kept below the lower explosive limit.

GUARANTEE

This instrument is guaranteed against any defect in material or workmanship for a period as specified on the enclosed guarantee card. This period is from the date of purchase, and within this period all defective parts will be replaced free of charge provided that the defect is not the result of misuse, accident or negligence.

Servicing under this guarantee should be obtained from the supplier. Notwithstanding the description and specification(s) of the units contained in the Instruction Book, Techne hereby reserves the right to make such changes as it shall see fit to the units or to any component of the units. This Instruction Book has been prepared solely for the convenience of Techne customers and nothing in this Instruction Book shall be taken as a warranty, condition or representation concerning the description, merchantability, fitness for purpose or otherwise of the units or the components.

CONTACT INFORMATION

If there is any doubt whatsoever relating to the proper use of this equipment our Sales or Technical Departments will be pleased to assist you. Similarly our Service Department will be pleased to assist you with any queries about servicing your FB-08.

For technical, sales or servicing information, contact your local Techne dealer or, Bibby Scientific Ltd.

TECHNICAL SPECIFICATION

General characteristics

Temperature range		50°C to 700°C
Temperature stability	dead bed stability (for 8 minutes)	±0.01°C
	at 50°C: short term	±0.2°C
	long term	±0.5°C
	at 600°C: short term	±0.3°C
	long term	±0.5°C
Nominal heater power		4 x 750W
Heat up time	from 20°C to maximum	1hr 45mins
Cool down time	from maximum to 200°C	2hrs 45mins
Electrical supply		240V 50/60Hz

Air supply

pressure	4.14 bar (60 psi)
maximum flow	127 l/min

Nominal dimensions and weights

Overall	width	770mm
	depth	515mm
	height	600mm
Internal dimensions	diameter	165mm
	depth	493mm
	usable depth below surface of fluidised medium	385mm
Weights		
	Unit (including fluidising medium) net	64Kg
	Chromatographic alumina	16Kg
	Basket	
	net	1Kg

INSTALLATION

Avoid siting the FB-08 in a laboratory environment which contains instruments that are sensitive to dust. Although the fluidised bath has its own dust extraction system, a small amount of fine dust may still be emitted during operation.

Power

The FB-08 requires a power supply of 240V 50/60Hz at 3KW; thus it can be run from a standard 13A socket.

Before connecting to the main supply check the voltage with that marked on the rating plate. Connect the mains cable to a suitable supply as follows:

Connection	240 V
Live	Brown
Neutral	Blue
Earth	Green/Yellow

Air

The FB-08 is supplied with integral filters and regulators suitable for normal clean dry air line supply between 60 and 125 lb/in². If the air supply is excessively dirty Techne can supply an additional external filter/regulator assembly which, if used, must be adjusted to its maximum setting of 60 lb/in². The air supply should be connected via suitable flexible hose to the hose tail at the rear of the left hand end of the bath.

Mechanical

The unit should be mounted on a firm level surface. Normal operation only requires access to the front of the units but periodic maintenance and servicing requires access to the left hand side also; this should be borne in mind when positioning the unit initially.

A bubble level (25) is built into the frame at the base of the front panel; this should be accurately levelled by adjusting the four corner feet (10). After final adjustment, all four feet should be firmly grounded and the unit should be level. Failure to do this can impair the operation of the unit. The surface should also be heat resistant.

Alumina

Fill the bath with sufficient of the alumina supplied so that it is 150mm (6") below the top surface of the unit before it is fluidized. The dust extraction system should be turned on during filling in order to minimise the amount of dust given off.

Should the fluidised bath be stored for long periods of time under damp or humid conditions, moisture may be absorbed by the alumina which is hygroscopic. To avoid violent fluidisation which occurs when damp alumina is heated above 100°C, operate the bath for a period of approximately 8 hours at 90°C prior to operation at elevated temperatures.

NEVER ADD COLD OR DAMP ALUMINA TO A HOT BATH AS THIS WILL ALSO CAUSE VIOLENT FLUIDISATION WHICH CAN BE DANGEROUS. Allow the bath to cool then add the fresh alumina. If this fresh alumina is a large proportion of the charge then dry the whole charge as above.

Note

To prevent damage during transit the float may have been removed from the flowmeter on the front panel. If so the following steps should be taken when installing the unit.

1. Remove the protective cover.
2. Remove the flow tube by first removing the plastic clip at the top of the flow tube, lift the flow tube up and remove the bottom of the tube clear of the flowmeter assembly. Pull the tube downwards from the top insert.
3. Fit the float with the pointed end down, into the tube.
4. Push the tube onto the top insert, line the tube up with the bottom insert, pull the flow tube and the top insert down until the flow tube is fully engaged on the bottom insert, refit the plastic clip.
5. Refit the protective cover.

CONTROLS

Mains on/off Switch (19)

Controls the mains input to the unit. This should be used in preference to the interlocks (see "heater indicator") when switching the unit off.

Mains Fuse (18)

Main fuse for the unit, rating 15A @ 240V AC.

Temperature Controller (16)

Units prior to Serial Number/5

When the mains switch (19) is set to the ON position the fluorescent indicator panel will display the measured value of temperature in digital form. Depress and release either the UP or DOWN button and the display will indicate the set point value for two seconds, and then revert to the measured value.

To alter the set point depress the respective UP/DOWN button and after a delay of two seconds the set point will change in the required direction. The nine segment bars situated to the left of the digital readout provide error percentages of measured values of temperature with respect to the set temperature. Illumination of the centre bar indicates within 1% of set point. The bars above and below the centrebar indicate, when illuminated, the upscale or downscale errors in increasing magnitude.

Temperature controller (16)

Units with Serial Number/5 to /8

When the mains switch (19) is set to the ON position the fluorescent indicator panel will display the measured and set temperature in digital form. To alter the set point depress the respective UP/DOWN button and after a delay of two seconds the set point will change in the required direction.

The following control parameters have been factory pre-set:

	810	808
Proportional Band	2%	7%
Integral	300sec	110sec
Derivative	40sec	3sec
Approach	3	-
Cycle Time	0.3sec	-
Maximum Power	100%	-

Temperature controller (16)***Units with Serial Number/9 onwards***

When the mains switch (19) is set to the ON position the fluorescent indicator panel will display the measured and set temperature in digital form. To alter the set point depress the respective UP/DOWN button and after a delay of two seconds the set point will change in the required direction.

The control parameters have been factory pre-set if you need to know the latest values contact the Service Department at Techne.

Fluidisation Air Control (21)

The valve at the bottom of the flowmeter controls the amount of air for fluidising the bed, the amount of flow being indicated by the float in the tube on a 2-25 scale.

Extraction Air Switch (22)

Turns the dust extraction system on and off. Without dust extraction fine dust from the bath could escape into the workroom atmosphere and although harmless, it has a nuisance value. The extraction system should, therefore, be used whenever the bath is running.

Dust Extraction Indicator (20)

Lights green when the dust extraction system is working.

Heater indicator (20)

Lights orange when the heaters are on. Heaters are interlocked so that they will only turn on when fluidising air is also on and exceeds a factory preset value.

OPERATION

The FB-08 calibration Fluidised Bath is capable of precise performance, but for reliable and consistent results it must be used by personnel conversant with its operation.

For temperature stability the heat input to the bath must exactly equal heat losses; the heat input from the immersed heaters is varied by the controller which has a characteristic time constant for its response to a change in demand. The heat losses from the bath are due to:

1. heating fluidising air
2. radiation from the top of the bath
3. conduction through the insulation
4. conduction along loads inserted into the bath
5. heating the mass of cold objects placed in the bath.

Changing any of these will affect the temperature of the bath, but it will recover under the controller's influence; this does mean, however, that after any parameter is changed or the load in the bath is changed, there is a delay before the bath temperature re-stabilises.

Start-Up

1. Check that the unit has been set up as described earlier and that required services are available.
2. Check that alumina level is correct and adjust if necessary. Never add new, cold alumina (which may contain moisture) to a hot bath. Should the fluidised bath be stored for long periods of time under damp or humid conditions, moisture may be absorbed by the alumina which is hygroscopic. To avoid violent fluidisation which occurs when damp alumina is heated above 100°C, operate the bath for a period of approximately 8 hours at 90°C prior to operation at elevated temperatures.
3. Check that fluidising air control valve and dust extraction control valve are both closed.
4. Connect bath to the electrical, and compressed air supplies.
5. Turn on mains power switch (19). The internal neon should illuminate.
6. Turn on dust extraction system switch (22), and the green lamp (20) should illuminate.
7. Open the fluidising air control valve (21) until the surface of the alumina rises and then starts to move with a gentle flowing action, like boiling cream. The amber heater light (20) should illuminate as should the controller when the fluidising air exceeds a preset pressure.
8. Set the desired operating temperature on the controller (16).
9. As the bath heats up, the indicated air flow for adequate fluidisation can be reduced - excess fluidising air does not improve performance, but does increase the risk of dust emission from the bath.
10. When the bath is at operating temperature, the controls should not be adjusted without good cause.

Calibration

1. When using the FB-08 to calibrate thermal sensors such as thermocouples and platinum resistance thermometers, it is important to ensure that the working volume of the bath is thermally stable. Use an independent temperature sensor, such as a reference thermocouple, to check the temperature uniformity and stability, see Specification.
2. The temperature stability of the fluidised bath at any operating temperature may be improved by tuning the control parameters of the temperature controller to match the performance of the system under any set conditions. Adjustment details are contained within the manufacturers instruction manual for the Eurotherm temperature controller.
3. For precise calibration the actual temperature of the fluidised bath should be measured with an independent calibrated reference sensor; the temperature indicated by the temperature controller should only be used as a guide and not as an indication of absolute temperature.
4. The number of sensors calibrated in the fluidised bath at any one time should be kept to a minimum so as not to disturb the flow pattern within the bath. Typically up to 10 sensors of approximately Ø10 mm may be calibrated without loss of performance.
5. The probe plate supplied with the FB-08 may be machined to allow the sensors being calibrated access to the bath. This probe plate should always be positioned above the surface of the bath in the probe plate carrier so as to inhibit the loss of fine alumina particles from the surface of the bath.
6. Techne are able to offer a work basket which ensures that the probes being calibrated are held within the working volume of the bath, alternatively custom built probe holders are available. Probe holders locate the sensors being calibrated at a known position within the bath and act as equalising blocks so that the basic isothermal properties of the fluidised bath are further enhanced.

Dead Bed Calibration

1. Temperature stability during calibration may be further improved by using a dead bed calibration technique. This technique involves heating the bath to the required calibration point, then allowing the temperature of the bath to stabilise for a period of approximately 20 minutes, dependent upon the actual calibration temperature and the thermal mass of the sensors being calibrated.
2. The fluidised bed is collapsed by cutting off the fluidising air to the FB-08 so that the sensors being calibrated are surrounded by a solid bed of alumina which acts as a thermal insulator. After a period of approximately 2 minutes at set temperature a stability of 0.01°C can be achieved for a further period of approximately 8 minutes, dependent upon heat loss along the stem of the sensors being calibrated.
3. At the end of the required period of dead bed it is necessary to reconnect the fluidising air to the FB-08.

Close Down

1. Turn off the mains power switch (19).
2. Close the fluidising air and nitrogen control valve (21).
3. Turn off the dust extraction system (22).
4. Disconnect the compressed air supply.
5. Disconnect the mains power.

SERVICING

Before any servicing is attempted the unit should be disconnected from the mains and allowed to cool down. In all cases maintenance and repair work should be undertaken only by a skilled technician. Untrained personnel should not attempt to dismantle the instrument.

Daily Maintenance (or as necessary)

Empty the cyclone collector bottle as follows (can be done whilst bath is hot):

1. Turn off the fluidisation air.
2. Turn off the dust extraction system.
3. Unscrew the bottle from the base of the cyclone unit.
4. Screw on the empty spare bottle.
5. Turn on the dust extraction system.
6. Turn on the fluidisation air until the bath is just fluidised.
7. Carefully and slowly empty the full bottle into the top of the bath. (Except for the first bottle from a new charge which should be thrown away). Note: During normal operation the collector bottle should only become partially full during an 8 hour period. An excessive amount of alumina in the collector bottle suggests that the fluidised bath has been overfilled with alumina, check the level in the bath. Add enough from the bottle to bring the bath to the correct level and keep the remainder as spare material.
8. Increase fluidisation up to the correct working level.
9. Check the filter and clean or replace if necessary, when the extraction system is switched off. (Note the screw and the filter may be hot).

Periodic Maintenance

The fluidised bath requires the following periodical inspection to be carried out to ensure trouble free operation:

The condition of the alumina should be checked to make sure that there are no lumps and, if practical, sieved occasionally. A fresh charge of alumina should be used if the medium is contaminated in any way.

Should the fluidised bath be stored for long periods of time under damp or humid conditions, moisture may be absorbed by the alumina which is hygroscopic. To avoid violent fluidisation which occurs when damp alumina is heated above 100°C, operate the bath for a period of approximately 8 hours at 90°C prior to operation at elevated temperatures. The heaters should be checked for discolouration, oxidation or to determine if any build up of alumina particles has taken place on the surface.

The condition of the porous plate should be checked to see whether there are any oil stains or discolourations: if so, and fluidisation is impaired, replace the porous plate.

The air supply filter should be checked to ensure that the auto drain system is working and that the filters are in good condition.

FAULT FINDING

The following guide has been prepared should a fault develop with the fluidised bath. The procedures laid down should be followed using only the specified replacement parts. If the fault cannot be located by using this guide, Techne carry full service facilities.

If the unit fails to operate, check the fuse, electrical and air supplies.

Fault

Poor fluidisation

Check

- a) Unit not level
- b) Inadequate air flow
- c) Inadequate air supply
- d) Air filters blocked
- e) Defective air flow meter
- f) Bath over-filled with alumina
- g) Fluidisation restricted by large mass placed in bath
- h) Porous plate blocked

Poor temperature control

It should be noted that in order to achieve good thermal conditions within the fluidised bath, it is important that the bath is properly fluidised. If all the instructions have been followed concerning the fluidisation in the operating procedure, there could be a fault with:

- a) The temperature control unit. A separate leaflet is provided which covers fault finding and service of this unit.
- b) The Triac/Solid State Relay.

Fault

Power on but air controller does not illuminate

Check

- a) Check there is no restriction in the supply.
Supply to the unit must be at 60 psi with 130 L/min flow.
- b) Check the blue silicone rubber tube, from the plenum chamber to the pressure switch, is in place. Check the stud in the centre of the plenum chamber is in place.
- c) Check the bath is filled with media to the correct level.
- d) With the extraction switch off, switch on the air supply, open the valve on the flowmeter until the float is at the top of the tube.
- e) If the float does not rise:
 - 1 Check the air supply again.
 - 2 Check the pipework for kinks and leaks. NOTE: The oil filter has a continuous bleed of air on the drain pipe.
 - 3 Check the regulator in the unit has not been closed.
NB. If the regulator is changed, air must be recalibrated to 10psi.
- f) If the float does rise, check the bed is fluidising.
- g) If the bed does not fluidise:
 - 1 Check for leaks in the pipework
 - 2 Check for leaks in the blue silicone tube
- h) If the bed does fluidise, switch on the extraction air.
- i) Check that the flowmeter float does not drop more than 5 L/min.
- j) If the float drops:
 - 1 The air supply is insufficient
 - 2 The air mover is out of adjustment
- k) If the float does not drop, switch on the power with the mains switch.
- l) Check the switch illuminates.
- m) If the mains switch does not illuminate:
 - 1 Check the mains supply
 - 2 Check the fuse
 - 3 Check the wiring
 - 4 Check the switch
- n) If the mains switch does illuminate check the controller display illuminates.
- o) If the controller does not illuminate:
 - 1 Check the wiring
 - 2 Check the micro switch is lifting (on the pressure switch).
 - 3 Lift the micro switch lever; if the controller illuminates then there is insufficient air; start again.
 - 4 If the controller does not illuminate when the micro switch is lifted the pressure switch is faulty or the controller is faulty.
 - 5 Replace the pressure switch and test again.
 - 6 If the fault persists replace the controller.

COMPONENT ACCESS

REMEMBER THAT HIGH VOLTAGES ARE EXPOSED WHEN THE CASE IS REMOVED AND THE UNIT IS PLUGGED INTO THE POWER.

Index	Page	Component
	17	To drain the Alumina fluidising medium
	18	To replace the Thermocouple
	18	To replace the Heaters
	18	To replace the Controller
	19	To replace the Air Filters
	19	To replace the Porous Plate
	20	To replace the Flowmeter Tube
	20	To replace the Fluidisation pressure switch (57)
	20	To replace the Fuse
	20	To replace the Triac/SSR

To drain the alumina fluidising medium

This is best done when the bath is cool as hot alumina can cause severe burns.

Ensure that the fluidisation air is turned off at the valve on the flowmeter (21), remove the drain cap (23) situated at the bottom rear of the unit. CAUTION, CAP MAY BE HOT. If the flowmeter has not been turned off and the unit is connected to the air supply, a jet of alumina will be released when the cap is removed. Fit the drain extension tube. Avoid over tightening. The bath may now be drained by very slowly turning on the fluidising air at the flowmeter until a steady flow of alumina is obtained. Hot alumina should be drained into a well insulated container of suitable material to avoid fire hazards. When the bath is empty remove the drain extension tube, clean the thread of the drain cap, and refit.

Note: Before replacing the thermocouple or the heaters the bath should be emptied of alumina, see para. 1 above. The air and electrical supplies must be disconnected at all times when servicing the system.

To Replace the Thermocouple

- Remove the top panel (1) by removing the screw at the left hand bottom corner, push up and pull out the panel.
- Remove the three screws securing the front panel (5) along the upper edge. DO NOT DISTURB SCREW WITH EARTH SYMBOL ALONGSIDE IT. Remove the knurled nut from the extraction switch (22) and lower the panel.
- Disconnect the thermocouple wires from the rear of the temperature controller (16) taking note of the polarity for reconnection.
- Slacken the thermocouple lock nut (52) back about 10mm. Unscrew the parallel bush (50) and remove the thermocouple (51). Access may be improved by disconnecting the hose (31) from the air mover (32).
- Reverse the operation for replacing the thermocouple ensuring that it does not touch the heater and that the sheath is clear of any electrical parts.

To Replace the Heaters

- a) Remove the upper front panel (1) as above.
- b) Turn the unit on its back to gain access to the heater terminations.
- c) Disconnect the wiring from the heaters (47) and remove the nuts (45) and washers (46) from the heater unions.
- d) Replace the unit on its feet and withdraw the heater through the top aperture.
- e) Reverse the operation to replace the heater fitting new seal washers (44) to the heater union. It may be necessary to spring the heater in order to pass the terminations through the holes. Should the heater lay too close to the wall of the inner container at the bottom, pull it away gently.

To Replace the Controller

Units with Serial Number prior to /5:

To remove the controller from the panel open the small panel at the bottom of the front face of the controller and with a screwdriver turn the screw in the bottom right hand corner counter clockwise. The instrument will start to withdraw from the sleeve and once the screw has been turned to its furthest extent the instrument can be withdrawn by hand.

Units with Serial Number/5 onwards:

With a screwdriver turn the screw at bottom of the controller counter clockwise. The instruments will start to withdraw from the sleeve and once the screw has been turned to its furthest extent the instrument can be withdrawn by hand.

To replace the controller ease the instrument by hand into the sleeve to its furthest extent. About 10mm will be left protruding. With a screwdriver turn the screw in the bottom right hand corner clockwise until tight. The instrument will be pulled completely into the sleeve, engaging the rear terminals, it is then fully secured.

Should it be necessary to remove the sleeve, first remove the controller as above. Remove the top panel (1) by removing the screw at the left hand bottom corner, push up and pull out the panel. Remove the three screws securing the front panel (5) along the upper edge. DO NOT DISTURB SCREW WITH EARTH SYMBOL ALONGSIDE IT. Remove the knurled nut from the extraction air switch (22) and lower the panel. Remove wiring from the rear of the sleeve, loosen the two retaining screws until it is possible to lift the screws outwards and push the mounting clamps into the sleeve. Replacement of the sleeve is in the reverse order.

To Replace the Air filters

Access to the compressed air filters can be gained through the front panel as above or through the bottom of the unit. To replace the particle filter element (60) or the oil filter element (62) turn off the air supply. Unscrew the transparent filter bowl, then unscrew the filter element. Note when replacing the oil filter element the small O ring between the element and the housing should also be changed. Filter bowls should only be cleaned with soapy water DO NOT USE SOLVENTS.

When refitting filter bowls, ensure that the rubber seal is in place.

NOTE: REGULATORS ARE FACTORY SET AND SHOULD NOT BE ADJUSTED.

To Replace the Porous Plate

It should be noted that replacement of the porous plate is rarely necessary; however, should the plate become blocked or damaged the following instructions should be followed.

- a) Empty the unit of alumina as in 1 above.
- b) Remove the jar (13) and turn the unit on its back.
- c) Disconnect the air line to the air supply point on the inside of the chassis (6) by unscrewing the knurled nut and pulling the plastic pipe clear.
- d) Remove eight nut and lock washers holding the chassis (6) to the LH wrapper (2), RH wrapper (3) and central wrapper (55), one bolt and lock washer situated in the recess for the dust extraction jar (13), and two lock nuts on the stud of the plenum chamber (42). Pull chassis clear.
- e) Remove 25 nuts, bolts and washers securing plenum chamber (42) to the inner container (41). Pull the plenum chamber clear and remove the porous plate (43).
- f) Clean any sealant from the flanges of the plenum chamber and inner container. A seal of Red Hermetite should be placed on both of the above flanges when fitting a new porous plate. Fit the porous plate while the seal is still wet, ensure that the porous plate and plenum chamber are correctly aligned with the offset hole in the inner container assembly.
- g) Refit the 25 nuts, bolts and washers and tighten them to a torque of 2.25-2.7 Nm (20-24 lb ins).
- h) Reverse the operation for replacing the chassis.

To Replace the Flowmeter Tube

- a) Remove the protective cover.
- b) Remove the flow tube by first removing the plastic clip at the top of the flow tube, lift the flow tube up and remove the bottom of the tube clear of the flowmeter assembly. Pull the tube downwards from the top insert.
- c) Fit the float with the pointed end down, into the tube.
- d) Push the tube on to the top insert, line the tube with the bottom insert, pull the flow tube and the top insert down until the flow tube is fully engaged on the bottom insert, refit the plastic clip.
- e) Refit the protective cover.

To Replace the Fluidisation pressure switch (57)

This is preset to cut off the electrical supply to the heater should the fluidisation air flow fall below 2 1/ min. It is secured to the central wrapper (55) Remove the top panel (1) by removing the screw at the left hand bottom corner, push up and pull out the panel. Remove the three screws securing the front panel (5) along the upper edge. DO NOT DISTURB SCREW WITH EARTH SYMBOL ALONGSIDE IT. Remove the knurled nut from the extraction air switch (22) and lower the panel.

To Replace the Fuse

A high speed fuse (18) is fitted in the fuse holder (17) on the front panel (5).

To Replace the Triac/SSR

Remove the top panel (1) by removing the screw at the left hand bottom corner, push up and pull out the panel. Remove the three screws securing the front panel (5) along the upper edge. DO NOT DISTURB SCREW WITH EARTH SYMBOL ALONGSIDE IT. Remove the knurled nut from the extraction air switch (22) and lower the panel. Remove the wiring from the triac (24), and remove the retaining screws. Fit the new triac, first smearing it with heatsink compound. Re-fit the wires and replace the front panel.

SPARE PARTS

Description	230V	200V
Porous Plate	6001557	6001557
Triac (Prior To Serial No / 5 On)	6008234	6008234
SSR (Serial No / 5 On)	6008457	6008457
Filter Element Part.	6009131	6009131
Filter Element Oil	6009132	6009132
Fuse	6008181	6008181
Thermocouple	6005282	6005282
Heater	6007477	6007477
Washer	6001081	6001081
Filter Exhaust	6007558	6007558
Tube for Flow Controller	6009120	6009120
Capsule for Pressure Switch	6000435	6000435
Controller (807)	6100713	6100713
Controller (2208L)	6104671	6104671
Mains Switch	6500937	6500937

ACCESSORIES

Accessories supplied as standard

6003948 Extension Tube 1 Not Illustrated

6007766 PROBE PLATE 1

Accessories available for the FB-08 are:

Probe holders (made to customers' requirements by Techne)

The FB-08 provides a calibration medium for a wide range of sensor shapes and sizes. However, in cases where there is a constant probe size, it is sometimes more convenient to use a probe holder as this provides a metallic thermal shunt so that the basic isothermal properties of the bath are further enhanced.

F7759 Basket/Probe Plate

F5915 Air Pressure Regulator/Filter

F120D Air Compressor 220/240V

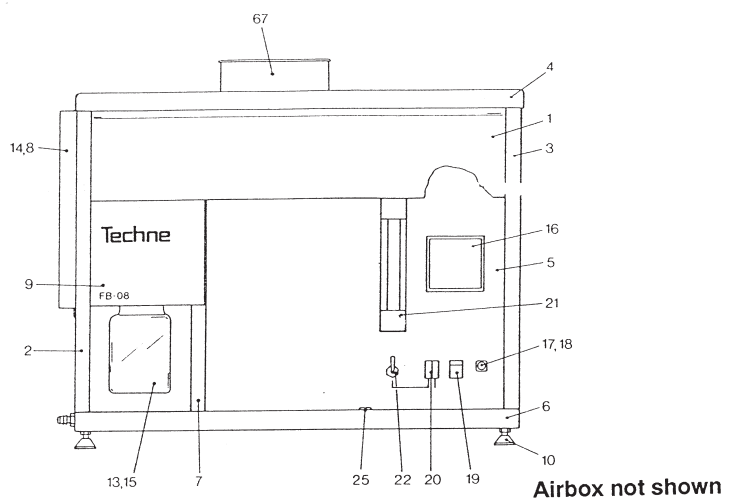

Front

Airbox not shown

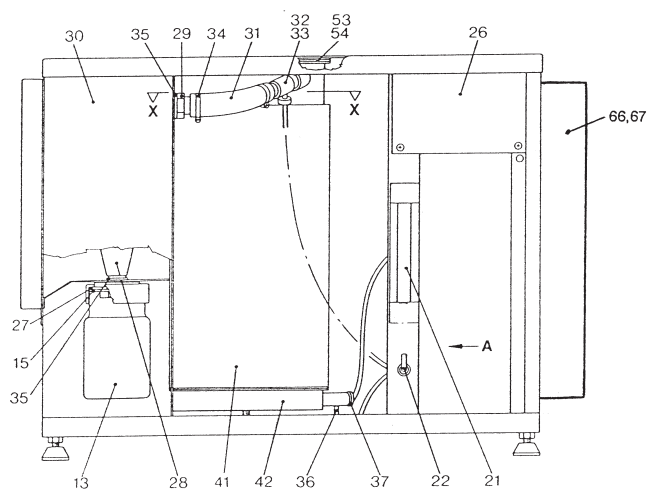

Front with the panels removed

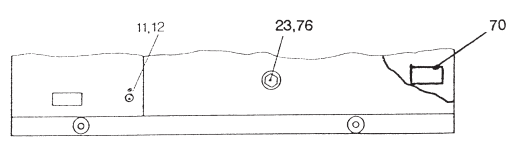

Part of Back

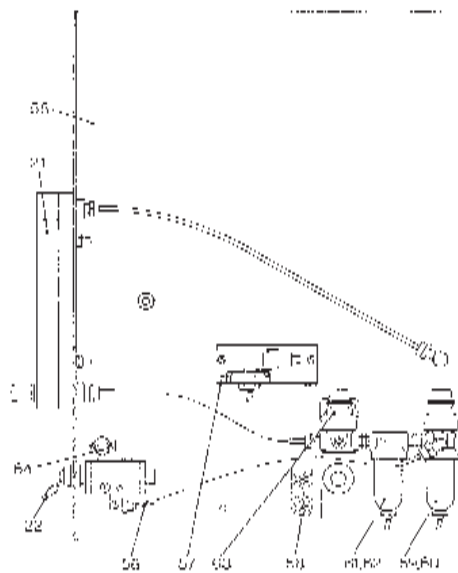

View on Arrow A

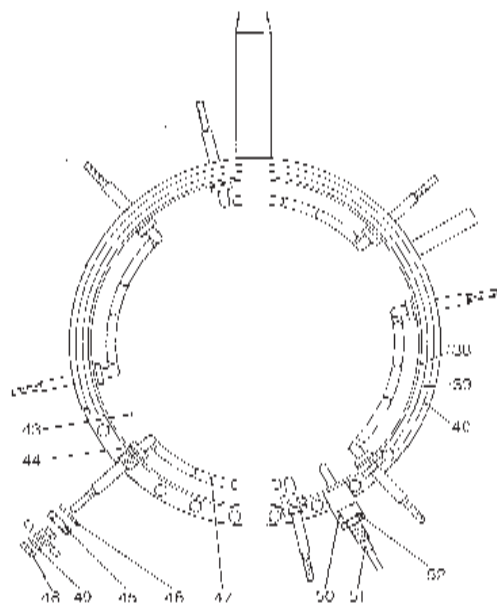

Section X-X

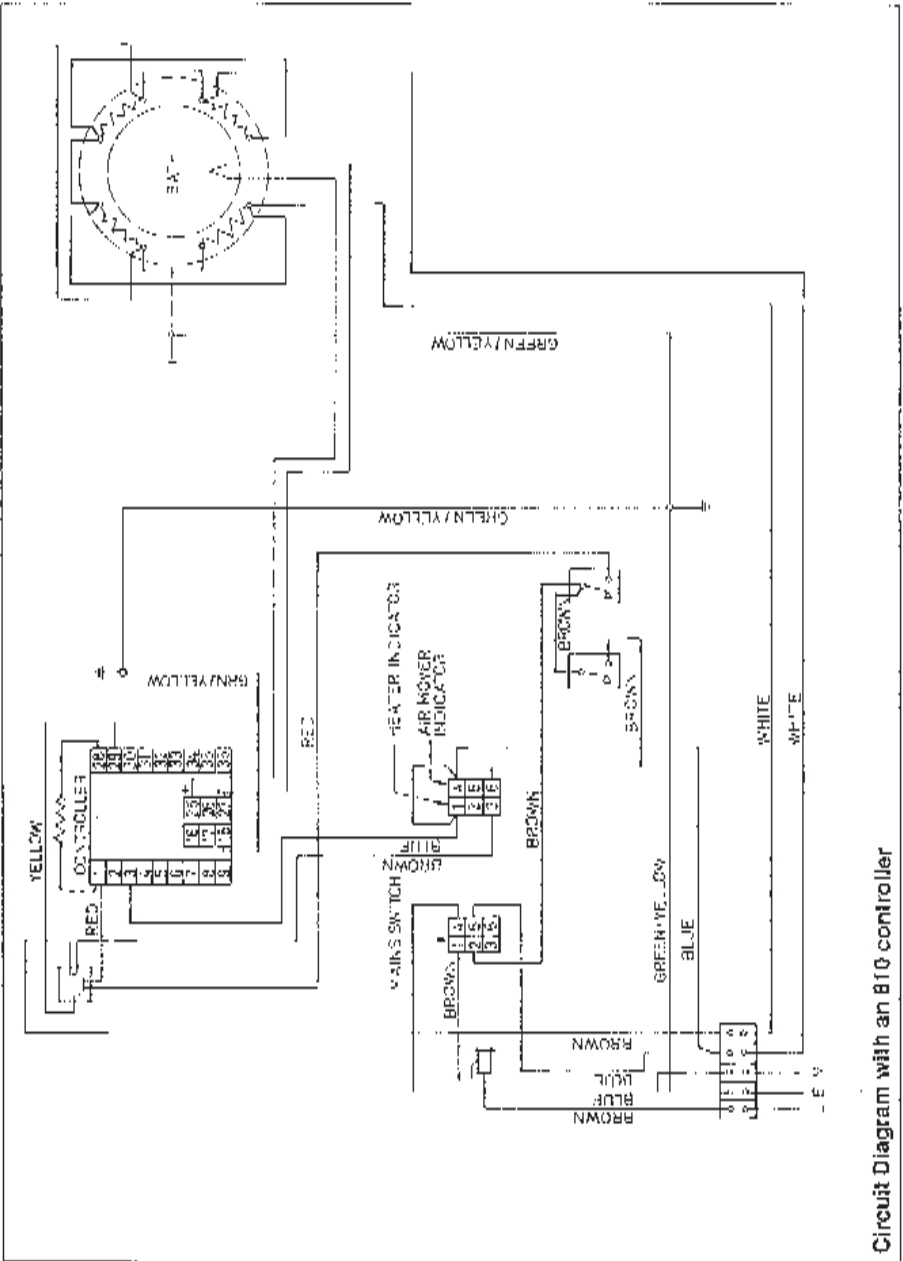

Circuit Diagram with an B10 controller

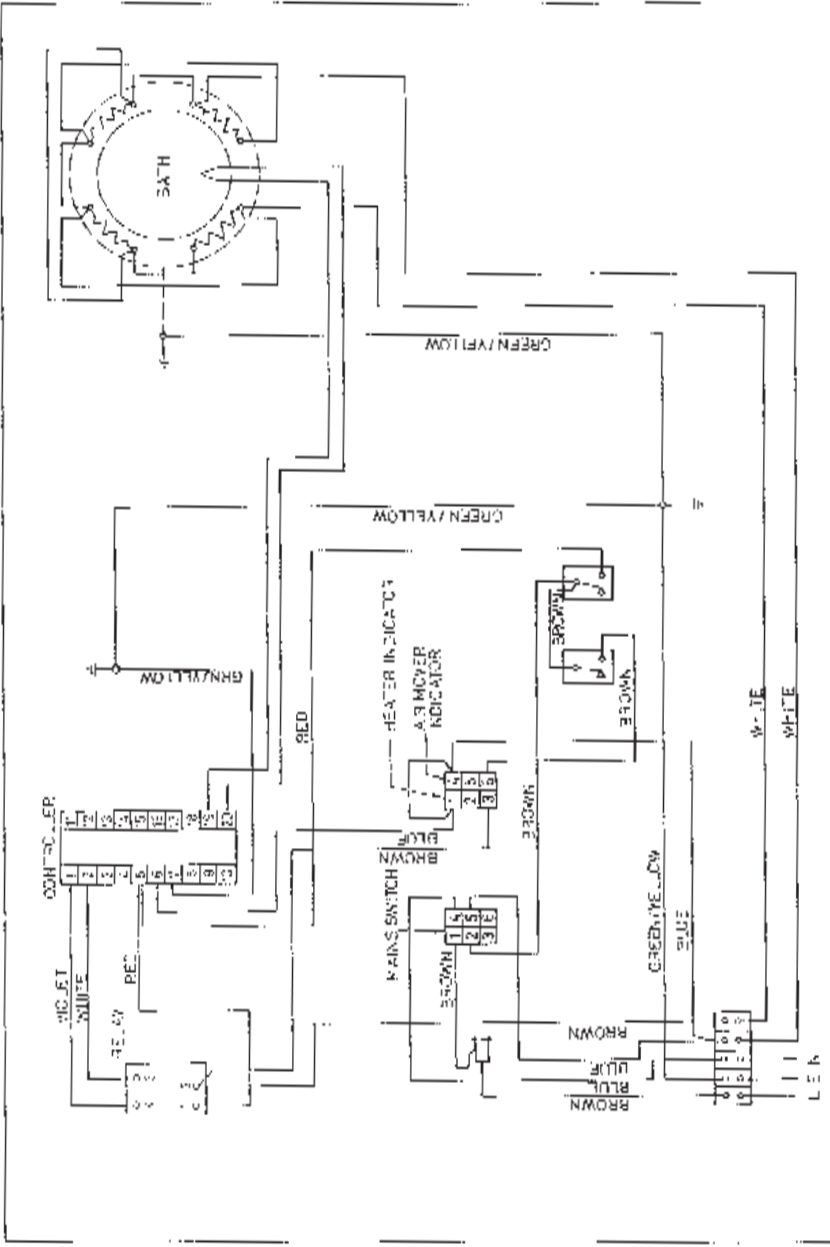

Circuit Diagram with an 808 controller
For units prior to Serial Number 6

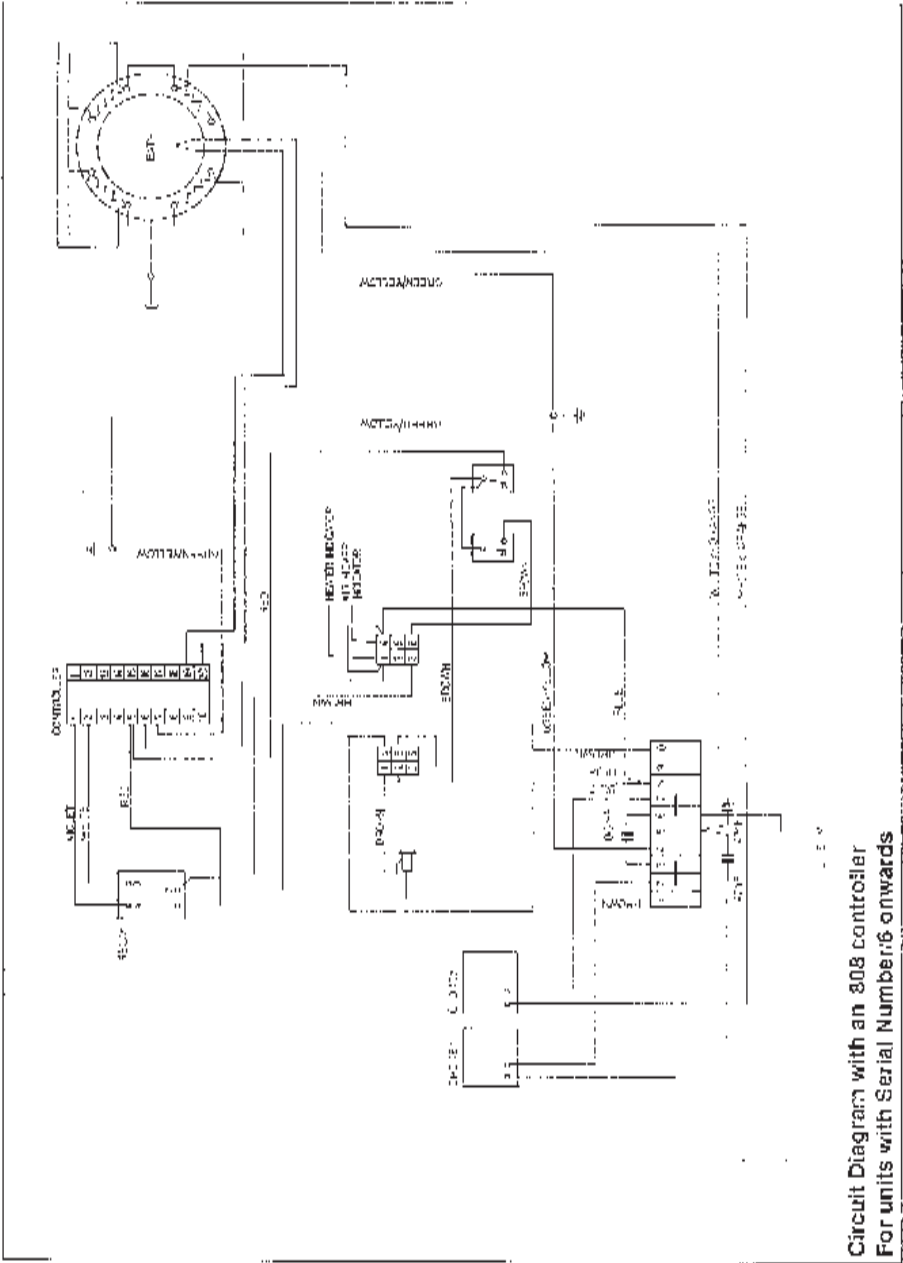

Circuit Diagram with an 308 controller
For units with Serial Number 6 onwards

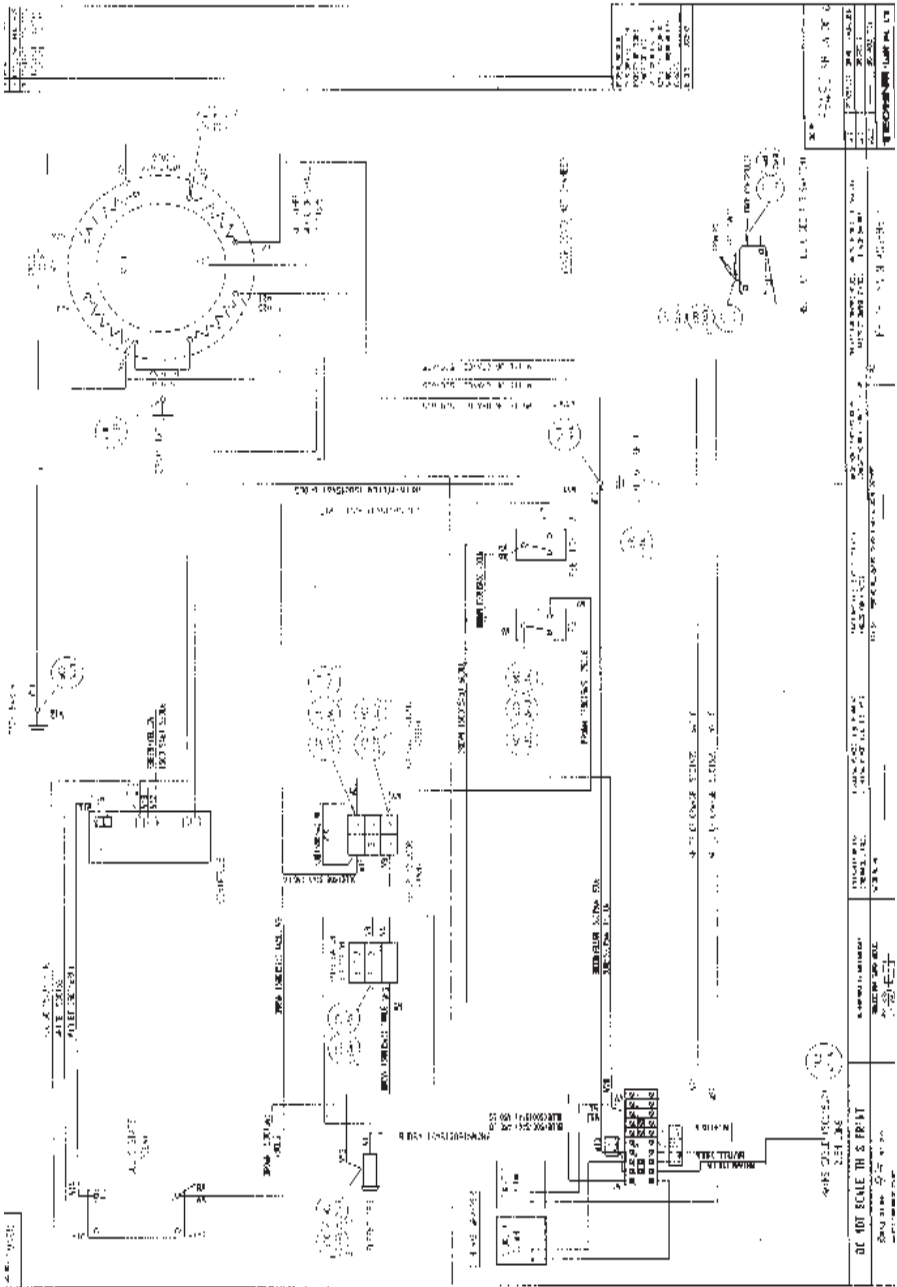

PROJET	1200000000
DATE	01/01/2000
REVISION	01

PROJET	1200000000
DATE	01/01/2000
REVISION	01

PROJET	1200000000
DATE	01/01/2000
REVISION	01

PROJET	1200000000
DATE	01/01/2000
REVISION	01



Thank you for reading this data sheet.

For pricing or for further information, please contact us at our UK Office, using the details below.



UK Office

Keison Products,

P.O. Box 2124, Chelmsford, Essex, CM1 3UP, England.

Tel: +44 (0)330 088 0560

Fax: +44 (0)1245 808399

Email: sales@keison.co.uk

Please note - Product designs and specifications are subject to change without notice. The user is responsible for determining the suitability of this product.