

Operating and Maintenance Instructions Model 140 Electropneumatic Transducer

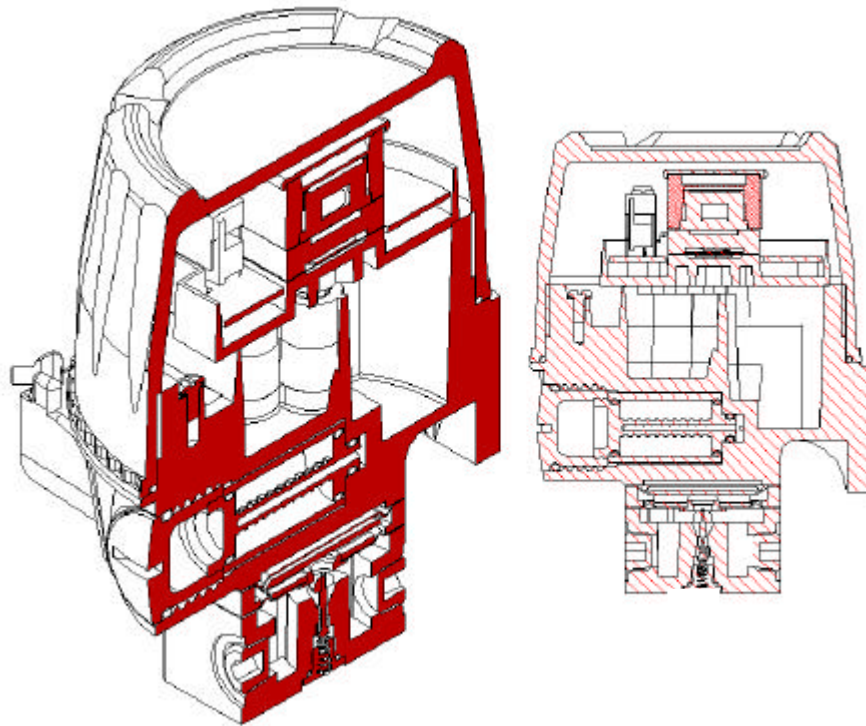

If installation instructions required in alternative European language please contact Watson Smith either by e-mail on enquiries@watsonsmith.com, or by telephone on +44 113 245 7587, or fax on +44 113 246 5735.

Pour obtenir cette documentation en d'autres langues, priere de contacter Watson Smith par e-mail a enquiries@watsonsmith.com, par telephone au +44 113 245 7587 ou par fax au +44 113 246 5735.

Sollten Sie dieses Handbuch in anderen Sprachen benötigen, wenden Sie sich bitte an Watson Smith unter der email-Adresse: enquiries@watsonsmith.com, oder rufen Sie unter der Nummer +44 113 245 7587 an oder faxen Sie unter der Nummer +44 113 246 5735.

Se vi occorre questo prontuario in una lingua diversa, siete pregati di contattare Watson Smith all 'indirizzo e-mail: enquiries@watsonsmith.com, oppure telefonare al n. +44 113 245 7587, o inviare un fax al n. +44 113 246 5735

Table of Contents

Page 3	Important: Safety Warnings
Page 4	Brief User Guide
Page 5	General Description
Page 6	Instrument Mounting
Page 7	Pneumatic Installation
Page 8	Electrical Installation
Page 8	Wiring and Cable Entry
Page 9	Certification Ratings and Diagrams
Page 12	Calibration and Maintenance
Page 15	Simple Functional Checks
Page 16	Technical Specifications
Page 17	Performance
Page 19	Hazardous Area Instructions (French)
Page 20	Hazardous Area Instructions (German)
Page 21	Hazardous Area Instructions (Italian)

Use of: Danger, Warning, Caution and Note.

These instructions contain DANGER, WARNING, CAUTION and NOTES where necessary to alert you to safety related or other important information.

DANGER – Hazards which result in severe personal injury or death

WARNING – Hazards which could result in personal injury

CAUTION – Hazards which could result in equipment or property damage

NOTE – alerts you to pertinent facts and conditions

Although **DANGER** and **WARNING** hazards are related to personal injury, and the **CAUTION** hazards involve equipment or property damage, it should be understood that operation of damaged equipment could, under certain operational conditions result in degraded process system performance which may lead to personal injury or death. Therefore comply fully with all **DANGER**, **WARNING** and **CAUTION** notices. Although a great effort has been made to ensure that these maintenance instructions are comprehensive the list of DANGERS, WARNINGS, PRECAUTIONS and NOTES cannot be regarded as a definitive list.

IMPORTANT: SAFETY WARNING

Please read these instructions carefully BEFORE this instrument is installed or maintained.

These converters are intended for use in industrial compressed air systems only. Ensure that adequate pressure relief provision is installed if application of system supply pressure could cause downstream equipment to malfunction. Installation should be in accordance with local and national compressed air and instrumentation codes.

Products certified for use in explosion-proof or intrinsically safe installations

MUST:

- a) Be installed in accordance with local and national codes for hazardous area installations, and in accordance with this manual.
- b) Only be used in situations which comply with the certification conditions stated in this handbook.
- c) Only be maintained by qualified personnel with adequate training on hazardous area instrumentation.

Before using these products with fluids other than air or for non-industrial applications consult Watson Smith.

Items sold by WATSON SMITH are warranted to be free from defects in materials and workmanship for a period of two years from the date of manufacture, provided said items are used according to WATSON SMITH'S recommended usages. WATSON SMITH'S liability is limited to the repair of, refund of purchase price paid for, or replacement in kind of, at WATSON SMITH'S sole option, any items proved defective, provided the allegedly defective items are returned to WATSON SMITH prepaid. The warranties expressed above are in lieu of and exclusive of all other warranties.

There are no other warranties, expressed or implied, except as stated herein. There are no implied warranties of merchantability or fitness for a particular purpose, which are specifically disclaimed. WATSON SMITH'S liability for breach of warranty as herein stated is the exclusive remedy, and in no event shall WATSON SMITH be liable or responsible for incidental or consequential damages, even if the possibility of such incidental or consequential damages has been made known to WATSON SMITH.

WATSON SMITH reserves the right to discontinue manufacture of any product or change product materials, design, or specifications without notice.

BRIEF USER GUIDE

This is a quick guide to connecting the instrument for the convenience of personnel who are familiar with this type of product.

More comprehensive instructions are contained later in this manual:

1. Connect a clean air supply of about 2.0 bar (30 psig) to the IN port (1/4" NPT).
2. Connect a pressure gauge or actuator to the OUT port.
CAUTION: DO NOT use PTFE tape or similar to seal the ports. Use a minimum of soft setting anaerobic compound, e.g. Loctite Hydraulic Seal 542
3. Unscrew the lid to obtain access to the terminals
DANGER: The cable will need to be sealed by an approved gland for explosion-proof installation.
DANGER: The second un-used conduit entry must be sealed with an explosion-proof blanking plug.
4. Connect a 4-20mA current source, either through the Jack-Plug source or Terminal connections. Ensure that it can supply at least 6.5V at 20mA. Check for correct polarity.
CAUTION: DO NOT use a voltage source; it will irreversibly damage the converter.
5. Switch on the air supply and current source and allow a few seconds stabilisation time. Adjust span and zero, via the trimpots if necessary.

If the instrument fails to operate refer to the Simple Functional Checks.

Diagram 1:

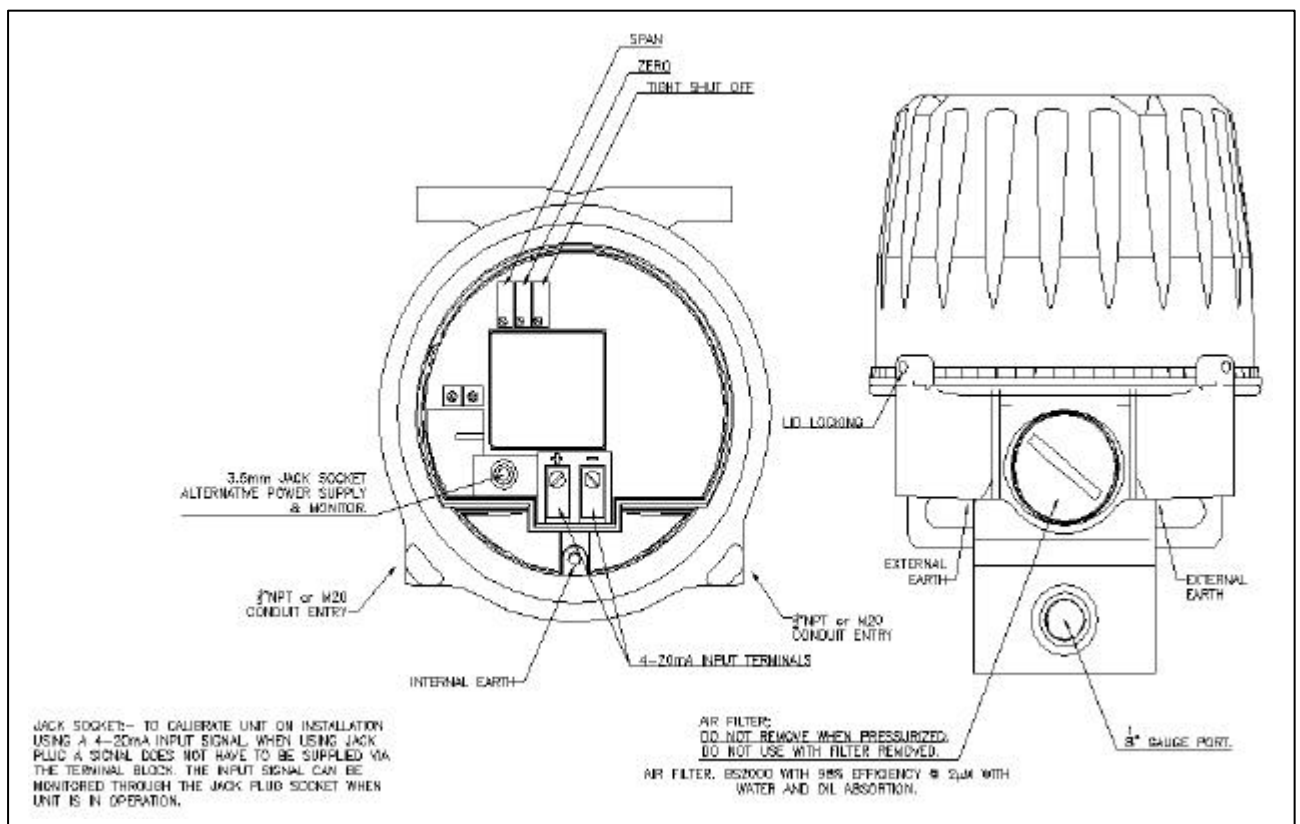

GENERAL DESCRIPTION

These converters are precision electronic pressure controllers designed for continuous process control applications. The units operate a closed loop system incorporating a feedback sensor ensuring long term stability and high accuracy performance, with 'fail-safe' operation, i.e. the output falls to a low pressure upon failure of the loop current.

These instruments combine substantial flow capacity, with the ability to give precise control into closed volume 'dead end' applications

The instrument has been designed to withstand the rigours of industrial environments; such as shock, vibration and positional effects. As with any other precision instrument dropping the unit onto a hard surface may result in shifts in calibration or possibly permanent damage. The unit may be mounted directly upon a control valve. A mounting bracket is provided for surface mounting, or the instrument may be fixed directly to rigid pipework.

The electronics are enclosed within a watertight housing which is suitable for outdoor use if a suitable cable gland is used. The lid should be firmly tightened, the use of a tool for this purpose is not recommended.

To meet the EMC specifications, screened cable should be used for installation. The cable screen should be connected to the internal earth bonding point of the I/P. An earth strap should also be connected from the external earth bonding point of the I/P to a common earth point. The cable screen should **not** be connected at the signal source when used in IS environments. The I/P has been thoroughly tested in accordance with

- | | |
|-------------------------|--|
| BS EN 61000-6-2: | Electromagnetic compatibility (EMC)
Generic Standards – Immunity for industrial environments |
| BS EN 50081-2: | Electromagnetic compatibility (EMC)
Generic Emissions Standard – Industrial environment |

Please consult wiring diagram for further information. The results obtained from these tests show that with the screen arrangement shown in the installation diagram, the typical sustained output pressure shift is $\pm 5\%$ full scale. Consult supplier for further details.

INSTRUMENT MOUNTING

The converter can be mounted directly onto a valve, onto any suitable flat surface, or onto 2" (50mm) pipe. Dimensional details:

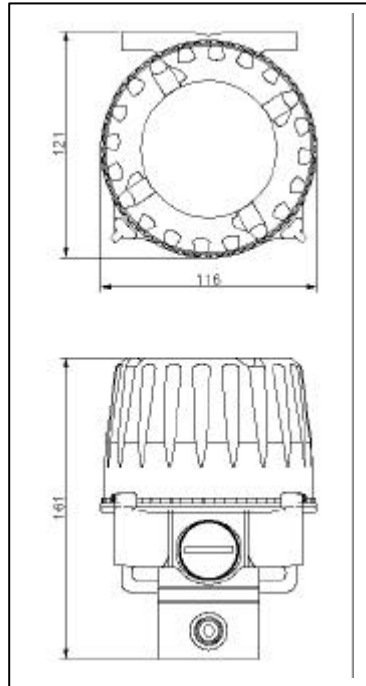

These converters will operate in any position, with slight re-calibration adjustments, normal operation is in the upright position, i.e. with the screwed lid horizontal. The unit is weather resistant when the lid is removed for connection or calibration, but should not be left uncovered during operation or for extended periods of time. They are unaffected by shock and vibration, but severe vibration environments are best avoided.

The instruments are protected against environmental effects, to a level of Type 4X (IP66). Sensible positioning should be used if the local environment is severe.

Temperature compensation is designed into these converters which will operate over a range from -40 to $+85^{\circ}\text{C}$ (-40 to $+185^{\circ}\text{F}$). Maximum life is obtained if extreme temperature cycling is avoided. In extreme direct sunlight, sun-shading is advised.

The pneumatic exhaust and the bleed are routed through the baffles. The baffles must not be blocked with paint and/or plastic sheeting etc.

PNEUMATIC INSTALLATION

These instruments are recommended for use with clean, dry, oil free instrument grade air to **BS.6739:1986 or ANSI/ASA-57.3 1975 (R1981)**.

Dew Point: At least 10°C (50°F) below (-40°C) minimum anticipated ambient temperature .

Dust: Filtered to below 50 microns

Oil Content: Not to exceed 1ppm mass.

The instrument is factory calibrated with a supply pressure of 30 psig (2 bar) $\pm 10\%$. Operation is possible at any pressure between 18 and 150 psig (1.3 to 10 bar), though recalibration may be necessary towards these limits to maintain specified accuracy.

The inlet and outlet ports are threaded 1/4"NPT female and suitable fittings should be used. For most installations 1/4" (6mm) pipe will be adequate. If a large actuator, high flow rates or long pipework is necessary then a larger diameter should be used.

Plastic tubing, e.g. Nylon is preferable where circumstances permit, since it is normally very clean internally. In all cases, purge the supply pipework before connection to the converter.

Two gauge ports are provided to facilitate direct mounting of a pressure gauge. To use one of these ports remove the plug (using a 1/4" or 3/16" Hexagon Key) in a de-pressurized state, and connect the gauge. The ports are threaded 1/4" NPT at the back of the unit and 1/8" NPT at the front.

CAUTION:

Under no circumstances should PTFE tape be used for sealing the fittings as this tends to shred small particles which may find their way into the instrument causing malfunctions.

The use of a soft setting anaerobic hydraulic seal is recommended, (e.g. Loctite Hydraulic Seal 542). Follow the manufacturers recommendations.

CAUTION:

Do not use an excessive amount as this will not set and could find its way into the instrument.

If the air supply is not of adequate quality this can normally be achieved by the use of air filter regulators, such as the Norgren Type B72G.

ELECTRICAL INSTALLATION

The electrical connections should be made as shown in the dimensional drawing diagram 1. The instrument is protected against reverse polarity to -100mA , no operation is possible in this condition.

The Model 140 approximates a constant voltage load of 6.5 volts across the loop terminals therefore it is essential that the loop controller be capable of providing a constant current in the range 4-20mA with an output voltage of at least 6.5 volts.

CAUTION:

Voltage output controllers (e.g. variable voltage power supplies) are entirely unsuitable for the Model 140 and could severely damage the electronic circuits.

WIRING AND CABLE ENTRY

WARNING:

These instruments must be installed in accordance with local and national codes of practice, especially for hazardous area installations. The instruments are fully isolated from ground and therefore grounding is unnecessary for functional purposes. However, grounding may be necessary to conform to installation codes.

NOTE: It is strongly recommended that shielded cable or a grounded conduit be used to achieve maximum RFI immunity, if the installation has any risk of electromagnetic interference.

CONDUIT ENTRY:

The instrument has twin conduit entry treaded 1/2" NPT or M20 (M20 as Cenelec Only Certified). For explosion proof installation, a sealed conduit gland conforming to explosion-proof specifications must be used. A ground terminal is provided both internally and externally and should be used if ground continuity is essential.

DANGER:

The unit is supplied with plastic blanking plugs, which must be removed before operation/calibration and replaced with a blanking plug conforming to the hazardous area certification rating applicable.

CERTIFICATION RATINGS AND DIAGRAMS

CENELEC APPROVAL HAZARDOUS AREA

1. Intrinsically Safe

EEx ia IIC T4
Ta=-40°C to +85°C
Ui=30V, li=110mA
Pi=0.84W
Ci=6nF, Li=100µH
Sira 01ATEX2007X
1G(T4)/1D(95°C)

2. Type 'n'

EEx nL IIC T5
Ta=-40°C to +85°C
li=24mA
Ci=6nF, Li=100µH
Sira 01ATEX4008X
3G(T5)/3D(95°C)

3. Flameproof

EEx d IIC T4
Ta=-20°C to +40°C
EEx d IIB+H₂ T5/T6
Ta=-20°C to +80°C (T5)
Ta=-20°C to +65°C (T6)
Umax=30V
Sira 01ATEX1006
2G(T4/T5/T6)/2D(95°C)
Do not open when an explosive gas or dust atmosphere is present

Instructions Specific to hazardous area installations (reference European ATEX Directive 94/9/EC, Annex II, 1.0.6)

The following instructions apply to equipment covered by certificate numbers
SIRA 01ATEX1006, SIRA 01ATEX4008X & Sira 01ATEX2007X

- 1 The Model 140 is Triple certified, and may be installed as intrinsically safe, flameproof or Type n:
 - Zone 0 or 20 installations require the equipment to be installed as intrinsically safe via suitable associated apparatus.
 - Zone 1 or 21 installations require the equipment to be installed as intrinsically safe or flameproof; if installed as flameproof, associated apparatus is not required, but there are more onerous requirements for cable entry – refer to EN50014:1997
 - Zone 2 or 22 installations may be intrinsically safe, flameproof or Type n
 - It is recommended that the installer indicates on the equipment which certification code applies
- 2 The equipment should not be used outside the stated ambient temperature range
- 3 The equipment has not been assessed as a safety-related device (as referred to by Directive 94/9/EC Annex II, clause 1.5)
- 4 Installation and maintenance of this equipment shall be carried out by suitably-trained personnel in accordance with the applicable codes of practice (EN 60079-14 and EN 60079-17 within Europe)
- 5 Repair of this equipment shall be carried out by the manufacturer or in accordance with the applicable code of practice (IEC 60079-19)
- 6 When installing the equipment as flameproof cable gland (M20 parallel thread) or a conduit (1/2" NPT tapered thread), the installer should verify the thread form and ensure

that the appropriate matching thread is used. The pneumatic connections are not flameproof entries.

- 7 The certification of this equipment relies on the following materials used in its construction:

Enclosure:	aluminium alloy and zinc alloy
O-ring:	nitrile rubber
Encapsulant:	polyurethane

If the equipment is likely to come into contact with aggressive substances, then it is the responsibility of the user to take suitable precautions that prevent it from being adversely affected, thus ensuring that the type of protection is not compromised.

- Aggressive substances: e.g. acidic liquids or gases that may attack metals, or solvents that may affect polymeric materials
 - Suitable precautions: e.g. regular checks as part of routine inspections or establishing from the material's data sheet that it is resistant to specific chemicals
 - Not to be used with pure oxygen or oxygen enriched media as the process fluid
- Consult the supplier for approval certificates.

FM APPROVAL HAZARDOUS AREA

1. Explosion Proof

CL I, DIV1, Groups BCD; T6 Ta=75°C, T5 Ta=85°C

2. Intrinsically Safe

CL I, II, III, DIV1, Groups ABCDEFG; T4 Ta=85°C

3. Non-Incendive

CL I, DIV 2, Groups ABCD; T6 Ta=75°C, T5 Ta=85°C

4. Dust Ingress Protection

CL II, III, DIV 1, Groups EFG; T6 Ta=75°C, T5 Ta=85 °C

5. Suitable For

CL II, III, DIV 2, Groups FG; T6 Ta=75°C, T5 Ta=85 °C

To prevent ignition of hazardous atmospheres do not remove cover while circuits are live. If installed in an ambient above 60°C, use field connectors rated for 90°C.

CSA APPROVAL HAZARDOUS AREA

1. Explosion Proof

CL I, Groups BCD;

CL II, Groups EFG;

CL III

Ex d IIC; T4

Ex d IIB+H₂; T5/T6

2. Intrinsically Safe

CL I, Groups ABCD;

CL II, Groups EFG;

CL III;

Ex ia IIC; T4

3. Type N

CL I, DIV 2, Groups ABCD;

Ex nL IIC, T5;

CL II, DIV 2, Groups EFG;

CL III

FM Approved Intrinsically Safe Control Drawing

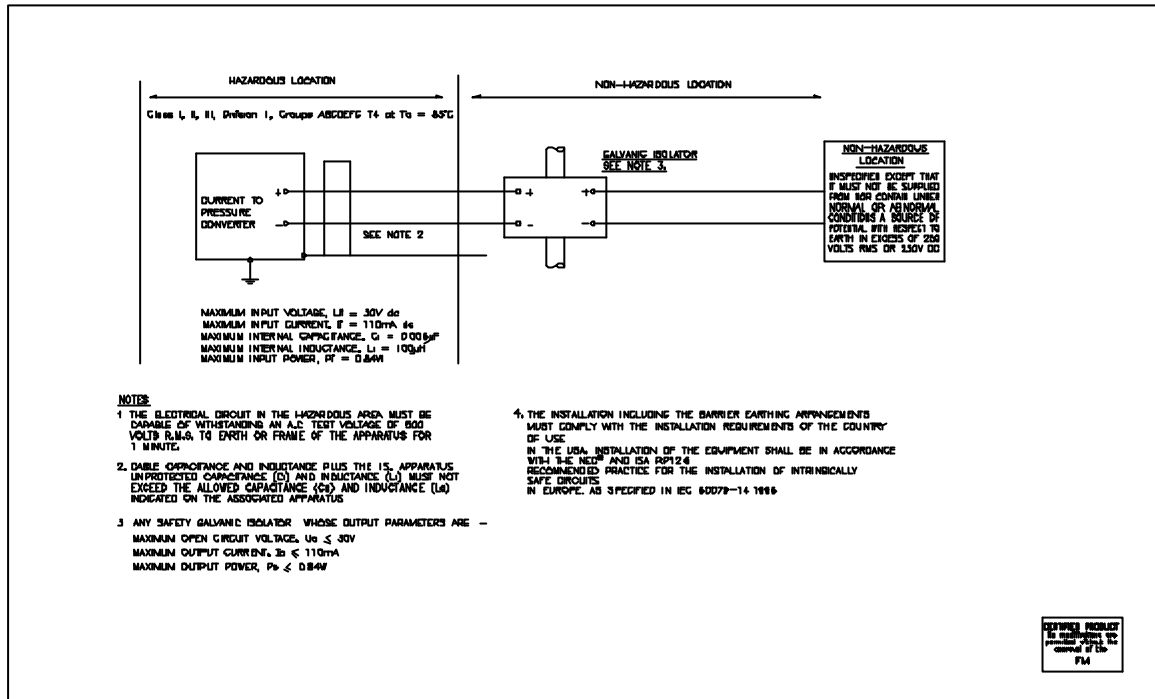

CSA Intrinsically Safe Control Drawing

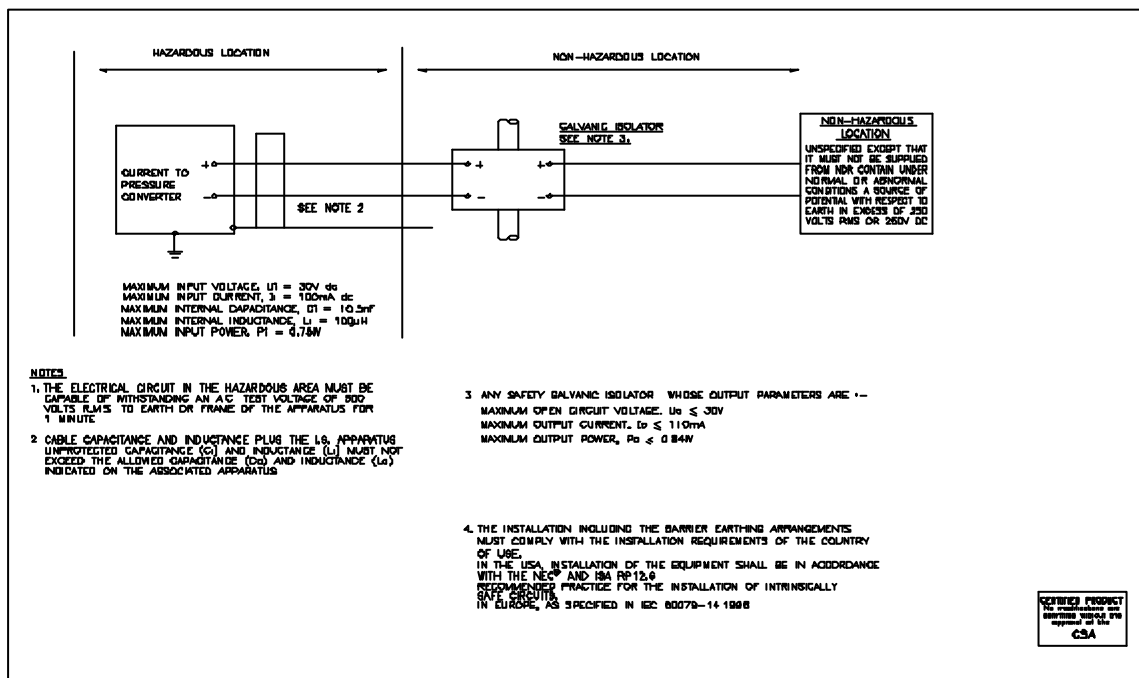

The following galvanic isolators are suggested for consideration when connecting in an IS configuration:

- MTL 5045 - Isolating 4/20 mA Driver
- Elcon HiD 2031 - Bus Powered I/P Driver
- Pepperl & Fuchs KFD2-CD-Ex1.32**

It is the responsibility of the installing organization to comply with the installation codes and standards applicable for a specific site, and therefore the above should be treated as suggestions for consideration only.

CALIBRATION AND MAINTENANCE

The instruments are designed for continuous operation without the necessity for routine overhaul, with continuous monitoring, adequate precautions and replacement of the filter no longer than every 5 years.

The most common source of failure for pneumatic instrumentation has been found to be inadequate air quality, allowing contaminants to block internal orifices. Air filtering is included within the instrument but cannot cope with sustained poor air quality, which may ultimately lead to failure.

The recommendations in the Pneumatic Installation section should be rigorously observed.

CALIBRATION

NOTE: These instruments are factory calibrated at a supply pressure of 30psig (2 bar)

The instrument cover must be unscrewed to obtain access to the trimpots.

DANGER: Do not remove the instrument cover in a potentially explosive atmosphere when the instrument is powered.

An accurate current source of 420mA and pressure gauge are required. These should be of good quality with an accuracy of 0.1% or better. The current source should be checked to ensure that it provides at least 6.5V at 20mA output compliance.

- Connect the instrument as described in the installation section or the test-jack section below.
- Remove the instrument cover to gain access to the trimpots and jack-socket.
- Set the current to 4.00mA – the instrument outlet should be 3.00+/-0.05psig (0.200+/-0.003 bar). Adjust the Zero trimpot if necessary.
- Set the current source to 20.00mA – the instrument outlet should be 15.00 +/-0.05psig (1.00+/-0.003 bar) Adjust the Span trimpot if necessary.

If either Span or Zero controls are adjusted it may be necessary to repeat the above steps until both ends are within the calibration limits.

Alternatively the jack plug can be connected to calibrate and test the unit. The Jack Plug can be either set-up for Monitoring or Calibration/Operation set-up.

Calibration with the Test Jack: connect pin 1 of the Jack plug to the positive (+) lead of the current calibrator and pin 3 of the Jack plug to the negative (-) lead of the current calibrator and then insert the Jack Plug into the Test Jack. The current calibrator is now the input signal source. Calibrate as stated above. Removing the Jack Plug will return operation of the unit back over to the original current source.

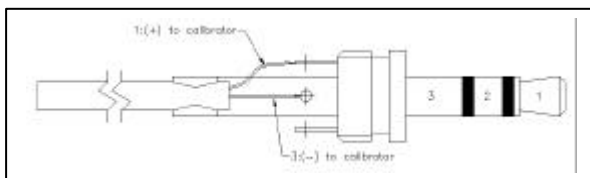

Monitoring with the Test Jack:

Connect pin 1 of the Jack Plug to the negative (-) lead of the ammeter and pin 2 of the Jack Plug to the positive (+) lead of the ammeter. Insert the Jack Plug into the Test Jack and use the ammeter to monitor the input current loop.

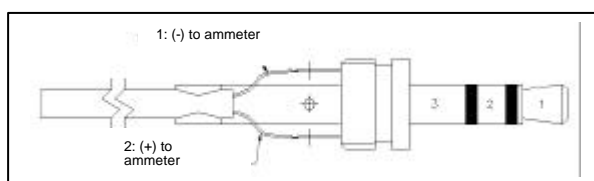

TIGHT SHUT-OFF ADJUSTMENT INSTRUCTIONS

The Tight Shut-Off potentiometer can be adjusted to set the zero point at which the instrument 'shuts off'.

For Example:

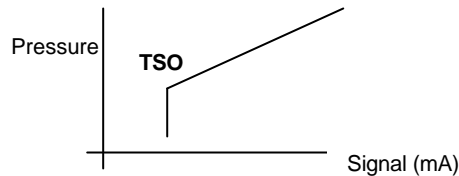

Tight shut-off is deactivated in the factory.

Setting of shut-off point:

1. With the instrument under test connected to the required supply pressure and load ports, apply a demand current signal of that value at which shut-off is required
2. If the output pressure is >start-up pressure (~0psi), adjust potentiometer slowly clockwise until the output pressure falls to zero, do not turn the pot beyond this point. The shut-off point is now set.

Shut-off point check:

Increase the input signal by approximately 0.5mA (e.g. to 3.8mA) the output pressure will rise above 0psi. Reset the input signal to the required shut off point (e.g. 3.3mA) and the output pressure will fall to zero.

MAINTENANCE

User maintenance is generally not to be recommended. The factory operates a repair service for defective instruments. In all cases repair should only be attempted by skilled and qualified personnel, who are familiar with this type of instrument. The replaceable filter should be replaced no less than once in five years. The quality of air used may require more frequent replacement of the filter, providing optimum operating conditions of the unit.

Field Replaceable Parts are Filter (part number 53ZZ0159), (use a suitable tool with a large blade to unscrew the filter part).

DANGER: Do not remove the filter part whilst the instrument is pressurised.

Electronics Module (part number ZZ0162) and Pneumatic Unit Base (ZZ0161).

WARNING: If unauthorised repairs are undertaken the hazardous area certification may be invalidated. Repairs can only be undertaken in accordance with the requirement of the applicable codes and standards for the site, such as IEC 60079 Part 19.

If local maintenance is to be undertaken, proceed as follows making reference to the exploded view diagram.

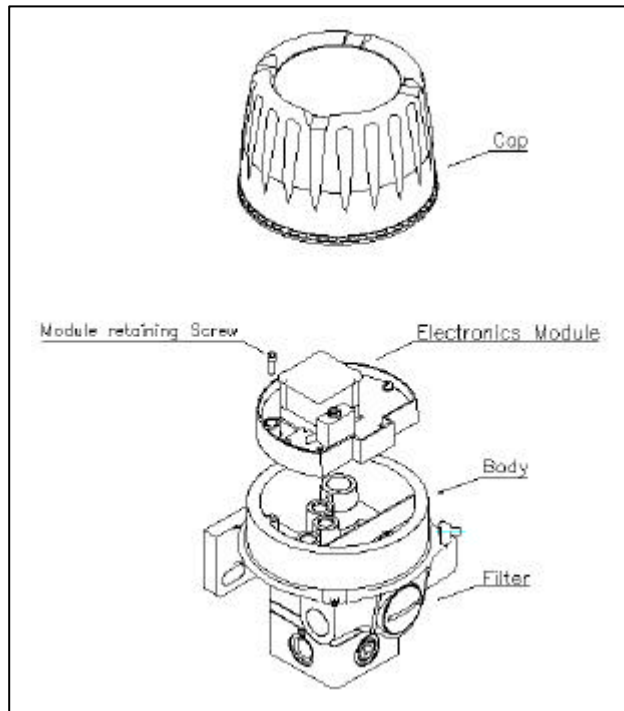
Exploded View Diagram:**Disassembly**

DANGER: Do not remove the instrument cover in a potentially explosive atmosphere when the instrument is powered.

Remove the instrument top cover by unscrewing counter clockwise. This gives access to the electronics module. The electronics module can be replaced as a complete kit assembly, (part number ZZ0162).

Remove the screw holding the electronics module onto the main casting; the module can then be lifted clear. Problems with the electronic circuitry are difficult to diagnose without specialist test equipment. Therefore the complete electronics module should be replaced.

If the lower, pneumatic section of the instrument is disassembled first note or mark the orientation of the square castings. There are internal air transfer passages which will be obstructed if correct orientation is not observed.

DANGER: For an Intrinsically Safe, Explosion-Proof or Type n/Non-Incendive unit, DO NOT REMOVE THE SINTERED FLAME ARRESTERS, or the certification will be invalidated.

Reassembly

Ensure that the flame arrestors have not been removed and that the cover thread is not damaged.

Reconnect the pneumatic tubes to their correct tube adaptors.

After functional test, replace the lid, ensuring that the sealing 'O' Ring is undamaged.

SIMPLE FUNCTIONAL CHECKS

Apply a 420mA signal and an air supply of 30 psig and observe the output on a pressure gauge. It should control smoothly. The Test Jack can also be connected as a monitor measure.

Problem	Possible Causes	Suggested Action
Maximum output not available	Supply pressure too low Calibration error Air leak in instrument Excess outlet flow	Check and adjust supply Recalibrate Locate leak and repair Check with specification
Minimum output too high	Calibration error	Replace Recalibrate
Delay on start up	A delay of a few seconds is normal	None
Erratic operation at low pressure	Signal currents below 3.5mA are insufficient for normal operation	Increase current. May need recalibration Tight shut-off set
No Output Available	Tight shut off potentiometer adjusted	Turn TSO anti-clockwise till clicking is heard
Erratic at all pressures	Controller cannot provide 6.5V continuously Contamination	Reduce loop resistance or change controller Check I/P filter status

TECHNICAL SPECIFICATIONS**FUNCTIONAL**

Input:	4-20mA (0-100%)
Output:	3-15psi and 15-3 psi Minimum output greater than 0.2psi
Supply Pressure:	150psi maximum, minimum 3psi above max required output pressure
Supply Pressure Effect:	Span over full supply pressure range <0.1%
Medium:	Standard instrument quality air to 50 micron
Air Consumption:	<2.5l/min (0.025scfm) at 50% signal
Operating Temperature:	-40°C to 85°C (-40° F to +185° F)
Relative Humidity:	0 to 100% Relative Humidity
Output Capacity:	>300l/min (12scfm) delivery and exhaust at 100% signal
Maximum Terminal Voltage:	Maximum 6.5Volts
Minimum Operating Current:	Less than 3.5mA
Current Reversal Protection:	No effect within normal 4-20mA range protected to 100mA continuous.
Insulation:	Electrical circuits are isolated from housing. Tested to 725V DC, 100MΩ

PERFORMANCE

(At 20°C (68°F), 30psi supply, 3-15psi range, for a typical instrument except otherwise stated);

Instrument Accuracy:	mean <0.1%
Independent Linearity	mean <±0.05% of span
Hysteresis, Resolution & Deadband	mean <=0.05% of span
Accuracy Rating:	<±0.75% span (including factory calibration error)

*Above figures are in accordance with ANSI/ISA 51.1:1993;
N.B. Instrument accuracy excludes calibration errors*

Temperature Effect:	Span and Zero Mean temperature coefficient over full operating range -40 to +85°C less than 0.035% span/degC
Vibration:	<3% of span; 4mm peak-peak 5-15Hz, 2g sine 15-150Hz
Mounting Position:	Integral bracket allows for mounting in any orientation
Long Term Stability:	Span and Zero Typically better than 0.25% span per year
Electromagnetic Compatibility:	Compliant with EC requirements: BS EN50081-2: EMC - Generic Emissions Standard – Industrial environment BS EN61000-6-2: EMC - Generic Standards – Immunity for industrial environments To meet the EMC specifications, screened cable should be used for installation. The cable screen should be connected to the internal earth bonding point of the I/P. An earth strap should also be connected from the external earth bonding point of the I/P to a common earth point. The cable screen should not be connected at the signal source when used in IS environments.
Controls:	Span and Zero and tight shut-off trimpots with 10% adjustment

PHYSICAL

Air Supply and Output Connections:	1/4" NPT supply and output; 1/8" NPT exhaust baffles to allow for captured bleed
Electrical:	1/2" NPT (M20 option); 2 internal screw terminals for 2.5mm ² cable
Weight:	2.07Kg

MATERIALS

Aluminium and zinc diecasting with nitrile diaphragms, epoxy powder coat painting as standard. Weatherproof to Type 4X (IP66) [mounted upright].

WatsonSmith

IMI Watson Smith Limited
 Cross Chancellor Street, Leeds LS6 2RT U.K.
 Tel: +44 (0)113 245 7587 Fax: +44 (0)113 246 5735
 E-mail: enquiries@watsonsmith.com
 Website: <http://www.watsonsmith.com>
 Video Conferencing: +44 (0)113 234 6526

**EC DECLARATION OF CONFORMITY FOR THE
 MODEL 140 PROPORTIONAL VALVE**

This is to certify that the Model 140 Proportional Valve Manufactured by:

**IMI Watson Smith Limited
 Cross Chancellor Street
 Leeds
 LS6 2RT**

Conforms with the protection requirements of Council Directive 89/336/EEC (amendments 92/31/EEC and 93/31/EEC) on the approximation of the laws of the member state, relating to electromagnetic compatibility SI 2372: 1992 (amendment SI3080:1994).

Representative samples of the Model 140 Proportional Valve have been tested/ evaluated (Report WS043-QTR-A) in accordance with:

- BS EN 50081-2:1994 Electromagnetic Compatibility
 Generic Emission Standard
 Part 2: Industrial Environment**

- BS EN 61000-6-2:1999 Electromagnetic Compatibility:
 Part 6-2: Generic Standards-
 Immunity for industrial environments**

To demonstrate compliance with Council Directive 89/336/EEC (amendments 92/31/EEC and 93/68/EEC)

Signed..... 

**C. Wheeler
 Technical Manager**

Date..... 10.8.01



**Instructions relatives aux installations en zone dangereuse
(référence Directive européenne ATEX 94/9/EC, Annexe II, 1.0.6)**

Les instructions suivantes sont d'application pour tout matériel couvert par les numéros de certificat SIRA 01ATEX1006, SIRA 01ATEX4008X et Sira 01ATEX2007X

- 1 Le modèle 140 est certifié par trois fois. Il peut être installé en tant qu'appareil à sécurité intrinsèque, antidéflagrant ou de type n :
 - Les installations dans les zones 0 ou 20 exigent que le matériel soit installé en tant que matériel à sécurité intrinsèque à l'aide le l'appareil accessoire adapté.
 - Les installations dans les zones 1 ou 21 exigent que le matériel soit installé en tant que matériel à sécurité intrinsèque ou antidéflagrant. S'il s'agit d'une installation antidéflagrante, un appareil accessoire n'est pas nécessaire mais ce type d'installation a des conséquences plus coûteuses quant aux entrées de câble – se référer à EN50014:1997
 - Les installations dans les zones 2 ou 22 peuvent être à sécurité intrinsèque, antidéflagrante ou de type n
 - Il est recommandé à l'installateur d'indiquer sur le matériel le code d'homologation qui est d'application
- 2 Le matériel ne peut pas être utilisé en dehors de la plage de température ambiante prévue
- 3 Le matériel n'a pas été jugé comme étant important pour la sécurité (ainsi que mentionné par la Directive 94/9/EC, Annexe II, clause 1.5)
- 4 Un personnel bien formé effectuera l'installation et l'entretien de cet équipement selon les codes de bonne pratique en application (EN 60079-14 et EN 60079-17 en Europe)
- 5 Les réparations de ce matériel seront réalisées par le fabricant ou selon le code de bonne pratique en application (IEC 60079-19)
- 6 Quand le matériel est installé comme presse-étoupe antidéflagrant (filet parallèle M20) ou comme conduit (filet conique NPT d'1/2"), l'installateur doit vérifier la forme du filet et veiller à utiliser le filet qui convient à l'assemblage Les raccords pneumatiques ne sont pas des entrées antidéflagrantes.
- 7 L'homologation de ce matériel repose sur l'utilisation des matériaux suivants dans sa fabrication :

Enceinte :	alliage d'aluminium et de zinc
Joint torique :	nitrile
couvercle :	polyuréthane

Si le matériel risque d'entrer en contact avec des substances agressives, il est de la responsabilité de l'utilisateur de prendre les précautions nécessaires pour empêcher qu'il ne soit abîmé et de veiller ainsi à sauvegarder son type de protection.

- Substances agressives : par ex. les liquides et gaz acidifiants qui peuvent attaquer les métaux ; ou les solvants qui peuvent agir sur les matériaux polymérisés
- Précautions adéquates : par ex. les contrôles réguliers faisant partie d'inspections de routine ; ou la vérification, d'après la feuille de données du matériel, qu'il résiste à des produits chimiques spécifiques
- Ne pas utiliser avec de l'oxygène pur ou des produits enrichis à l'oxygène comme fluide de transformation

Consulter le fournisseur pour les certificats de conformité.

**Sondervorschriften für Anlagen in explosionsgefährdeten Bereichen
(Quelle: Europäische ATEX-Richtlinie 94/9/EC, Zusatz II, 1.0.6)**

Die im Folgenden genannten Vorschriften gelten für Geräte mit den Zertifikatsnummern SIRA 01ATEX1006, SIRA 01ATEX4008X und Sira 01ATEX2007X

- 1 Das Modell 140 ist dreifach zertifiziert und kann als Gerät, das ein sehr hohes Maß an Sicherheit gewährleistet bzw. schwer entzündbar ist, oder als Gerätetyp n installiert werden:
 - Kategorie 0 oder 20 Anlagen: die Geräte müssen durch entsprechend verbundene Apparatur ein sehr hohes Maß an Sicherheit gewährleisten.
 - Kategorie 1 oder 21 Anlagen: die Geräte müssen ein sehr hohes Maß an Sicherheit gewährleisten bzw. schwer entzündbar sein; wenn sie als schwer entzündbare Geräte installiert werden, ist keine verbundene Apparatur erforderlich, allerdings gibt es weitere wichtige Voraussetzungen für Kabeleinführungen – siehe EN50014:1997.
 - Kategorie 2 oder 22 Anlagen: die Geräte müssen ein sehr hohes Maß an Sicherheit gewährleisten, schwer entzündbar oder Gerätetyp n sein.
 - Es ist zu empfehlen, dass der Installateur auf den Geräten die jeweils gültige Zertifizierungsnorm ausweist.
- 2 Die Geräte sollten nicht bei Temperaturen eingesetzt werden, die außerhalb des festgelegten Umgebungstemperaturbereichs liegen.
- 3 Die Geräte sind nicht als sicherheitsbezogene Apparatur beurteilt worden (siehe Richtlinie 94/9/EC Zusatz II, Klausel 1.5).
- 4 Die Geräteinstallation und –wartung sind von ausreichend ausgebildetem Personal gemäß den entsprechenden Normen für den praktischen Gebrauch durchzuführen (EN 60079-14 und EN 60079-17 innerhalb von Europe).
- 5 Die Geräte-Reparatur ist vom Gerätehersteller oder gemäß den entsprechenden Normen für den praktischen Gebrauch durchzuführen (IEC 60079-19).
- 6 Bei der Installation der Geräte als schwer entzündbare Kabelleitung (M20 parallele Leitung) oder als Kabelleitung (1/2" NPT Trapezgewinde) sollte der Installateur die Kabelform überprüfen und gewährleisten, dass das entsprechende passende Kabel verwendet wird. Die pneumatischen Verbindungen bestehen aus Kabeleinführungen, die leicht entzündbar sind.
- 7 Die Geräte-zertifizierung ist von folgenden bei der Konstruktion verwendeten Materialien abhängig:

Gehäuse:	Aluminiumlegierung und Zinklegierung
Rundschnurring:	Nitrilkautschuk
Kapselungsmaterial:	Polyurethan

Wenn die Geräte leicht in Kontakt mit aggressiven Stoffen kommen können, liegt es in der Verantwortung des Benutzers, die erforderlichen Maßnahmen gegen nachteilige Auswirkungen zu treffen und somit zu gewährleisten, dass der Schutztyp nicht beschädigt wird.

- Aggressive Stoffe: z.B. flüssige Säuren bzw. Gase, die Metalle angreifen können, oder Lösungen, die Polymermaterialien beeinflussen können
- Entsprechende Maßnahmen: z.B. regelmäßige Überprüfungen als Bestandteil von Routineinspektionen oder aus dem Datenblatt des Materials hervorgehender Nachweis darüber, dass das Material gegen spezielle Chemikalien resistent ist.
- Nicht zusammen mit reinem Sauerstoff oder mit Sauerstoff angereicherten Medien als Prozessflüssigkeit verwenden.

Wenden Sie sich für Zulassungszertifikate an den Lieferanten.



Thank you for reading this data sheet.

For pricing or for further information, please contact us at our UK Office, using the details below.



UK Office

Keison Products,

P.O. Box 2124, Chelmsford, Essex, CM1 3UP, England.

Tel: +44 (0)330 088 0560

Fax: +44 (0)1245 808399

Email: sales@keison.co.uk

Please note - Product designs and specifications are subject to change without notice. The user is responsible for determining the suitability of this product.